

Инструкция

Дельтовидные стоя Impulse IFP1103

Полезные ссылки:

[Дельтовидные стоя Impulse IFP1103 - смотреть на сайте](#)

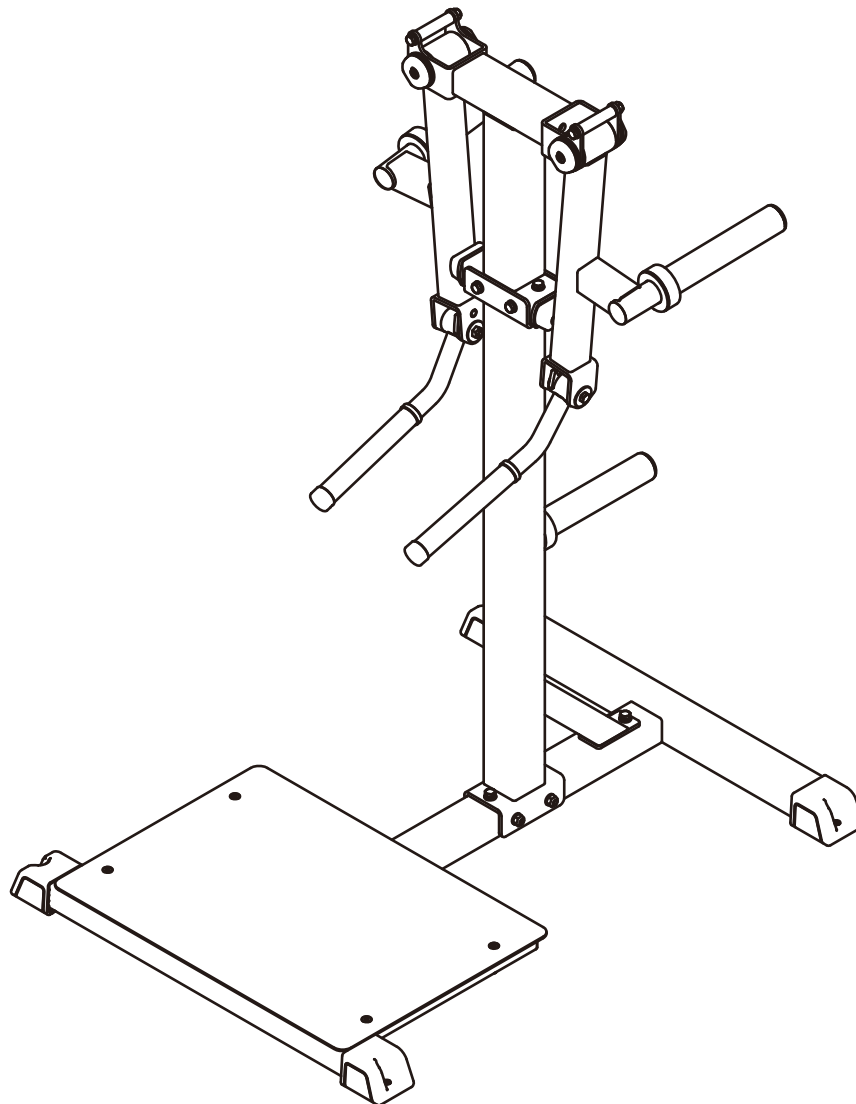

IFP1103

Standing Lateral Raise

OWNER'S MANUAL

22D

CAUTION! Read all precautions and instructions in this manual before using this equipment.

Table Of Contents

CAUTION!

Read all precautions and instructions in this manual before using this equipment.

Important Safety Instructions-----	3
Instructions-----	5
Exploded View and Parts List-----	6
Measurement Guide-----	12
Assembly Instructions-----	13
Assembly-----	14
Adjust and Exercise Instruction-----	18
Maintenance Schedule-----	19
General Maintenance Information-----	20
Weight Training Tips-----	21

Important Safety Instructions

Before beginning any fitness program, you should obtain a complete physical examination from your physician. When using exercise equipment, basic precautions should always be taken, including the following:

1. Read all instructions before using the equipment.
These instructions are written to ensure your safety and to protect the unit.
2. Use the equipment only for its intended purpose as described in this guide.
Do not use accessory attachments that are not recommended by the manufacturer: such attachments might cause injuries.
3. The product should only be used on a level surface and is with 0.6 meters space around the product.
Do not use the equipment outdoors.
4. Do not allow children on or near the equipment. And children are not allowed to use this equipment.
Teenagers should use this equipment with adult supervision.
5. Do not overexert yourself or work to exhaustion.
Do not attempt to lift more weight than you can control safely.
If you feel any pain or abnormal symptoms, stop your workout immediately and consult your physician.
6. This equipment is not used as medical apparatus and instruments.
7. Never operate the unit when it has been dropped or damaged.
Never drop or insert anything into any opening in the equipment.
Always check the unit and its cables before each use. Make sure that all fasteners and cables are secure and in good working condition.
Frayed or worn cables can be dangerous and may cause injury. Periodically check these cables for any indication of wear.
Keep hands, limbs, loose clothing and long hair well out of the way of moving parts.
8. Be careful when getting on or off the equipment.
9. Wear proper exercise clothing and shoes for your workout, no loose clothing.

Important Safety Instructions

Personal Safety During Assembly

Read each step in the assembly instructions and follow the steps in sequence. Do not skip ahead. If you skip ahead, you may learn later that you have to disassemble components and that you may have damaged the equipment.

Assemble and operate the equipment on a solid, level surface. Locate the unit a few feet from walls or furniture to provide easy access. The equipment is designed for your enjoyment. By following these precautions and using common sense, you will have many safe and pleasurable hours of healthful exercise with the equipment.

Training Area and Free Area

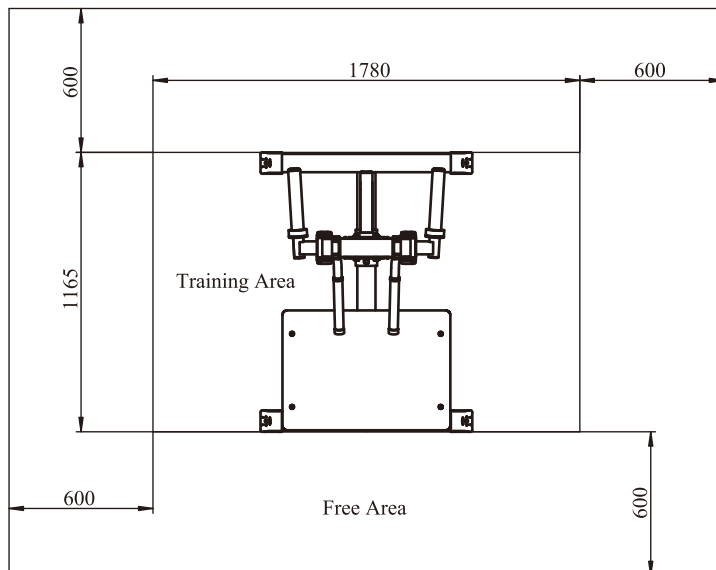

Specifications

Class: S

Maximum Wt. Capacity: 2*100kg/ 220lbs

Maximum User Weight: 150kg/ 330lbs

Product Dimension: 1165*883*1551mm

Product Total Surface: 1165*1780mm

Product Total Mass:

Instructions

Before beginning assembly please take the time to read instructions thoroughly. Please use the various lists in this manual to make sure that all parts have been included in your shipment. When ordering, use part number and description from the lists. Use only our replacement part when servicing. Failure to do so will void your warranty and could result in personal injury.

The equipment is designed to provide the smoothest, most effective exercise motion possible. After assembly, you should check all functions to ensure correct operation. If you experience problems, first recheck the assembly instructions to locate any possible errors made during assembly. If you are unable to correct the problem, call your authorized dealer. Be sure to have your serial number and this manual when calling. When all parts have been accounted for, continue on.

Tools Required

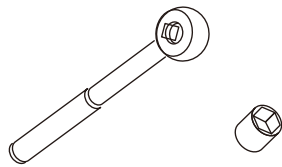

Ratchet Wrench and Socket

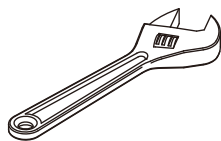

Adjustable Wrench

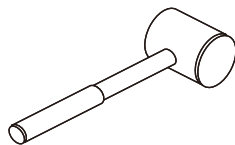

Rubber Mallet

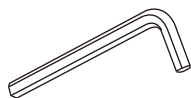

Hex Key Wrench Set

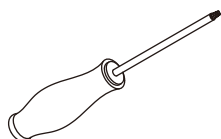

Phillips Screwdriver

Exploded View and Parts List

Overall

Item No.	Part No.	Description	QTY
1	IFP110301ASSY	Bottom Frame ASSY	1
2	IFP110302ASSY	Stand Frame ASSY	1
3	IFP110303ASSY	Left Swing Frame ASSY	1
4	IFP110304ASSY	Right Swing Frame ASSY	1
5	IFP110305ASSY	Left Handle Frame ASSY	1
6	IFP110306ASSY	Right Handle Frame ASSY	1
7	IFP110307ASSY	Top Stand Frame ASSY	1
8	HSPCF481000	Shaft $\Phi 25 \times 94$	2
9	IN-D21103500	Shaft $\Phi 25.4 \times 69$	2
10	IF93062200	Washer $\Phi 62 \times \Phi 10.5 \times 3$	4
11	FE97211900	Cap $\Phi 60$	4
12	FE97212000	Circle Ring $\Phi 62.5$	4
13	GB70M10*25DHS20NL	Socket Head Cap Screw M10*25	4
14	GB5780M10*30DHS20NL	Hex Head Bolt M10*30	3
15	GB5780M10*75DHS20	Hex Head Bolt M10*75	2
16	GB5780M10*85DHS20	Hex Head Bolt M10*85	2
17	GB5780M10*105DHS20	Hex Head Bolt M10*105	4
18	NM10DHS2	Nylon Lock Nut M10	8
19	GB9310DHS12	Spring Washer $\Phi 10$	3
20	GB9510DHS2	Flat Washer $\Phi 11 \times \Phi 20 \times 2$	15
21	DQ10DHS2D	Flat Washer $\Phi 11 \times \Phi 38 \times 2$	4

Exploded View and Parts List

Overall

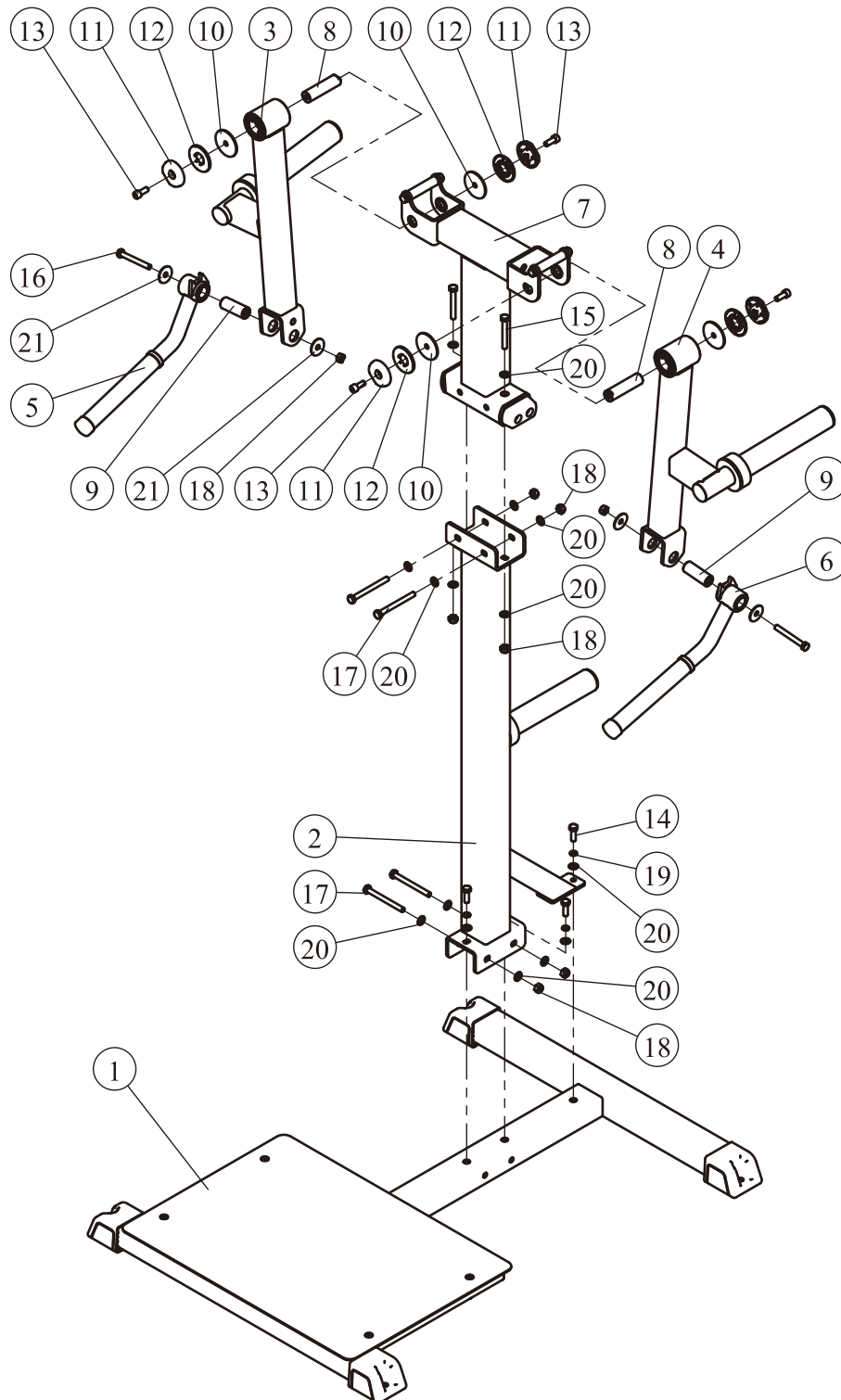

Exploded View and Parts List

Bottom Frame Sub ASSY

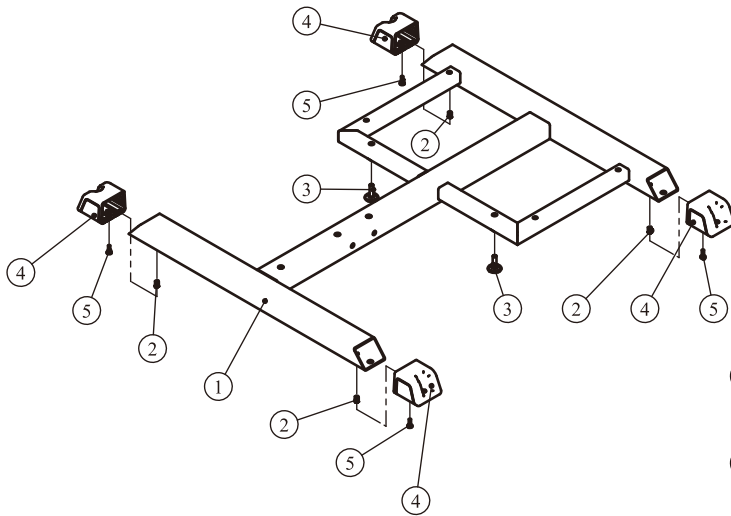

Bottom Frame ASSY

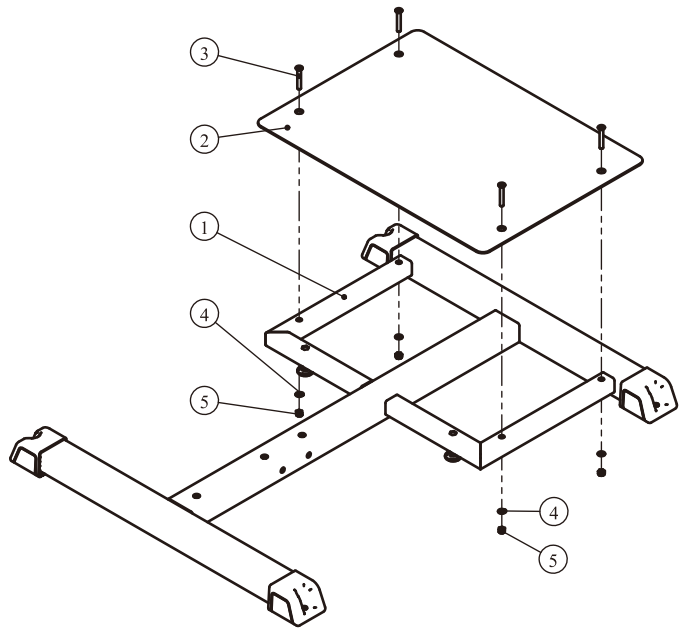

Grade No.	Part No.	Description	QTY
1.1.1	IFP11030100	Bottom Frame	1
1.1.2	GB17880.3M6*15DS17	Rivet Nut M6	4
1.1.3	DC135K34000	Adjustable Foot Plate	2
1.1.4	IFP12013300	Ground Plug	4
1.1.5	GB818M6*20DHS2	Cross Recessed Pan Head Screw M6*20	4

Grade No.	Part No.	Description	QTY
1.1	IFP11030100ASSY	Bottom Frame Sub ASSY	1
1.2	IFP11030800	Foot Plate	1
1.3	CNLM8*55DHS20	Flat Head Cap Screw M8*55	4
1.4	GB958DHS2	Flat Washer $\Phi 9 * \Phi 16 * 1.6$	4
1.5	NM8DHS2	Nylon Lock Nut M8	4

Exploded View and Parts List

Stand Frame ASSY

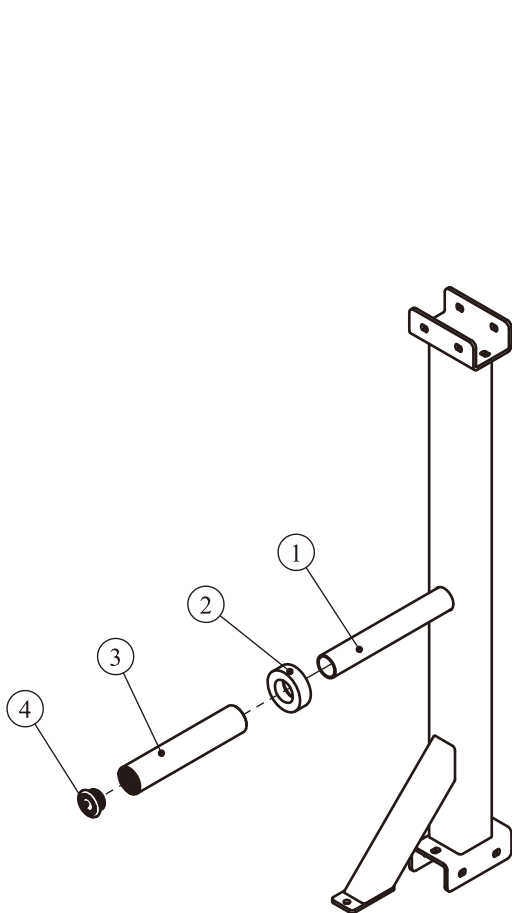

Top Stand Frame ASSY

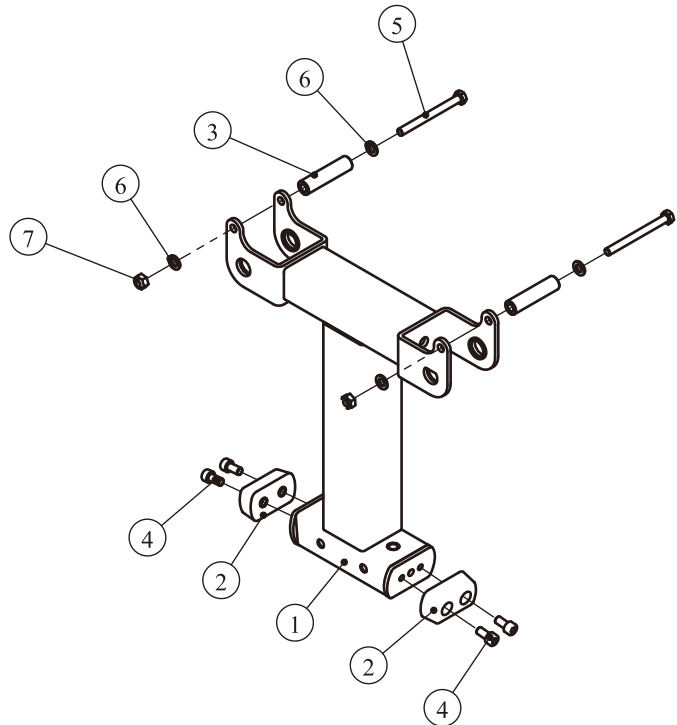

Grade No.	Part No.	Description	QTY
2.1	IFP11030200	Stand Frame	1
2.2	HF985A1500	Rubber Bumper	1
2.3	IFP12013400	Weight Horn Sleeve	1
2.4	IFP12013500	Tube Plug $\Phi 45$	1

Grade No.	Part No.	Description	QTY
7.1	IFP11030700	Top Stand Frame	1
7.2	RS17000400	Rubber Bumper	2
7.3	HSPXF0018500	Nylon Sleeve	2
7.4	GB70M10*20DHS20NL	Socket Head Cap Screw M10*20	4
7.5	GB5780M10*110DHS20	Hex Head Bolt M10*110	2
7.6	GB9510DHS2	Flat Washer $\Phi 11*\Phi 20*2$	4
7.7	NM10DHS2	Nylon Lock Nut M10	2

Exploded View and Parts List

Left Swing Frame ASSY

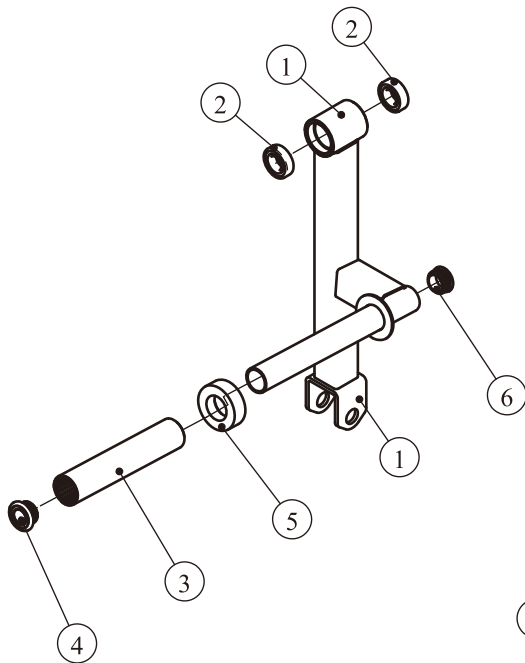

Right Swing Frame ASSY

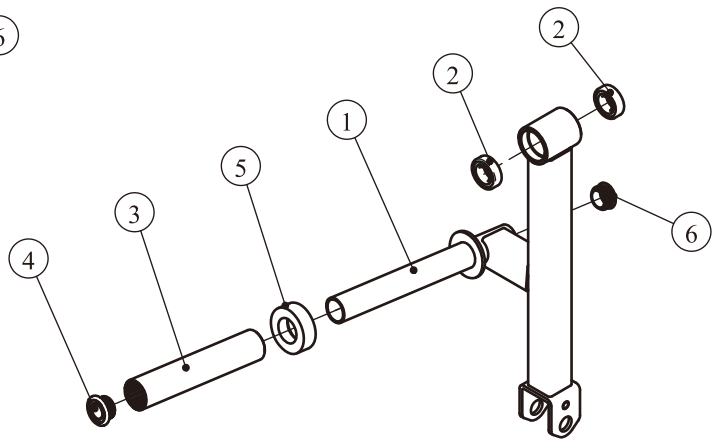

Grade No.	Part No.	Description	QTY
3.1	IFP11030300	Left Swing Frame	1
3.2	GB2766205-2ZC3	Bearing 6205	2
3.3	IFP12013400	Weight Horn Sleeve	1
3.4	IFP12013500	Tube Plug $\Phi 45$	1
3.5	HF985A1500	Rubber Bumper	1
3.6	HF985A1700PBC	Tube Plug $\Phi 42$	1

Grade No.	Part No.	Description	QTY
4.1	IFP11030400	Right Swing Frame	1
4.2	GB2766205-2ZC3	Bearing 6205	2
4.3	IFP12013400	Weight Horn Sleeve	1
4.4	IFP12013500	Tube Plug $\Phi 45$	1
4.5	HF985A1500	Rubber Bumper	1
4.6	HF985A1700PBC	Tube Plug $\Phi 42$	1

Exploded View and Parts List

Left Handle Frame ASSY

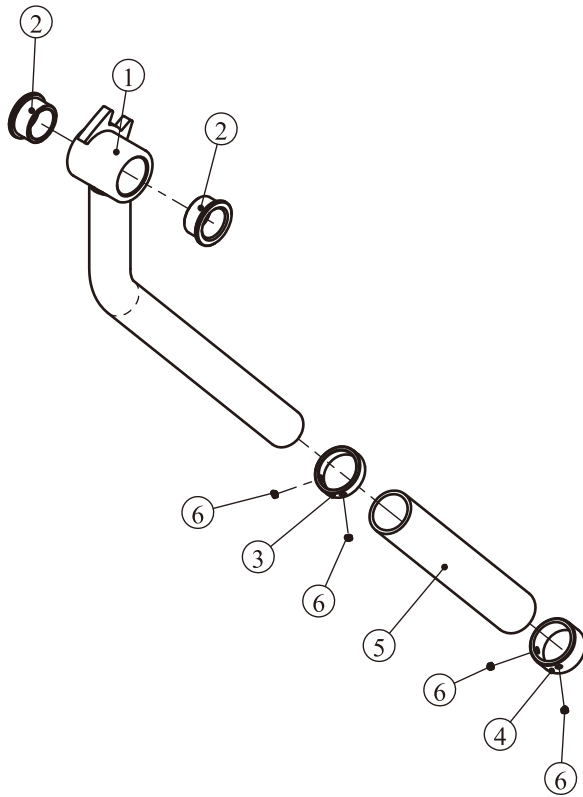

Right Handle Frame ASSY

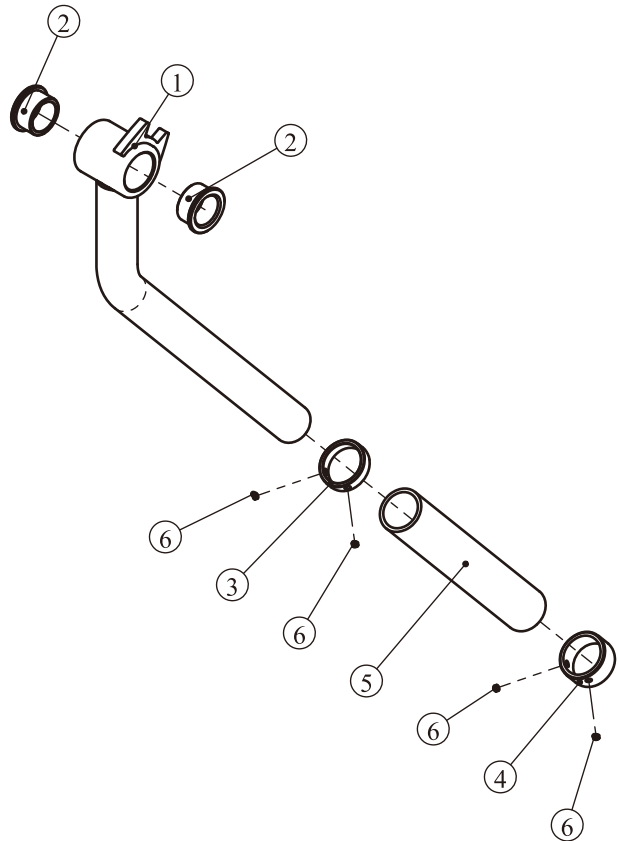

Grade No.	Part No.	Description	QTY
5.1	IFP11030500	Left Handle Frame	1
5.2	M02502000	Bushing	2
5.3	V38900	Aluminum Grip Ring $\Phi 32$	1
5.4	V39000	Aluminum Grip Cap $\Phi 32$	1
5.5	026-01PL0235-23	Grip	1
5.6	YZGB7710-32*3.2N19	Socket Set Screw 10-32UNF*3.2	4

Grade No.	Part No.	Description	QTY
6.1	IFP11030600	Right Handle Frame	1
6.2	M02502000	Bushing	2
6.3	V38900	Aluminum Grip Ring $\Phi 32$	1
6.4	V39000	Aluminum Grip Cap $\Phi 32$	1
6.5	026-01PL0235-23	Grip	1
6.6	YZGB7710-32*3.2N19	Socket Set Screw 10-32UNF*3.2	4

Measurement Guide

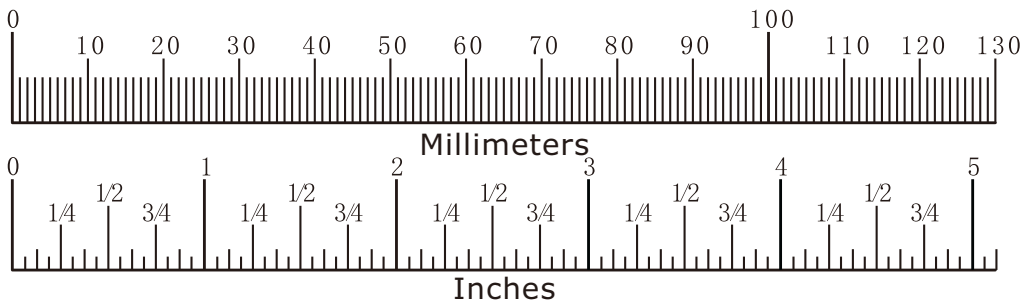
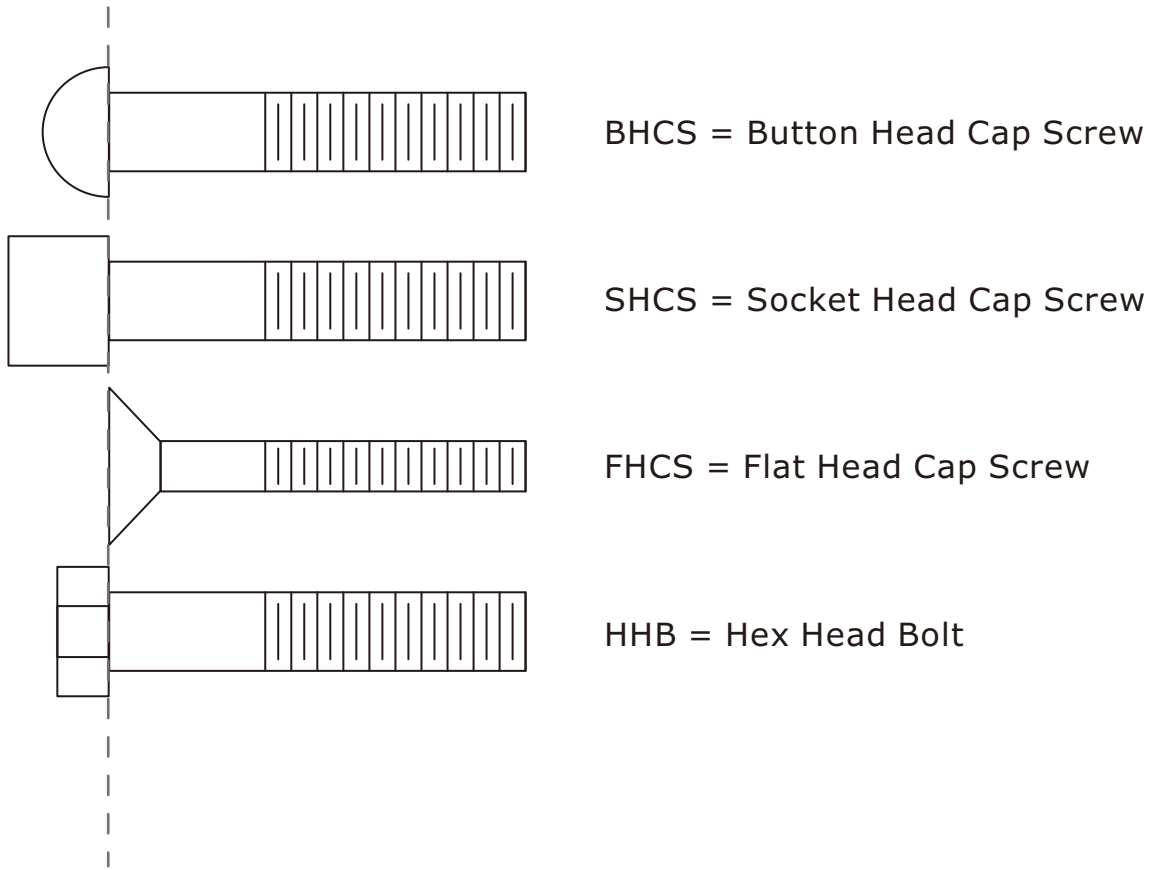

Diameter of bolt (mm/inch)	M6(1/4")	M8(5/16")	M10(3/8")	M12(1/2")	M16(5/8")
Tightening torque (N.m)	9~12	22~30	45~59	78~104	193~257
Operational methods for adult men	The strength of the wrist	The strength of the wrist and forearm	The strength of the entire arm	The strength of the arm and upper body	with all strength

Assembly Instructions

Assembly of the equipment takes professional installers about 2 hours. If this is the first time you have assembled this type of equipment, plan to spend more time. It is strongly recommended to assemble the equipment by professional installers. You may find it quicker, safer, easier to assemble this equipment with the help of a friend, as some of components may be large, heavy or awkward to handle alone. It is important that you assemble your product in a clean, clear, uncluttered area. This will enable you to move around the product while you are fitting components and reduce the possibility of injury during assembly.

NOTE

As with any assembled part, proper alignment and adjustment is critical. While tightening the fasteners, be sure to leave room for adjustments. Do not fully tighten the fasteners until instructed to do so. Be careful to assemble the components in the sequence presented in this guide.

Assembly

STEP 1

Attach the Stand Frame ASSY (#2) to the Bottom Frame ASSY (#1) using:

three M10*30 HHB (#14)

two M10*105 HHB (#17)

two M10 Nylon Lock Nut (#18)

three Φ 10 Spring Washer (#19)

seven Φ 11* Φ 20*2 Flat Washer (#20)

Note: Wrench Tighten Bolts and Nylon Lock Nuts.

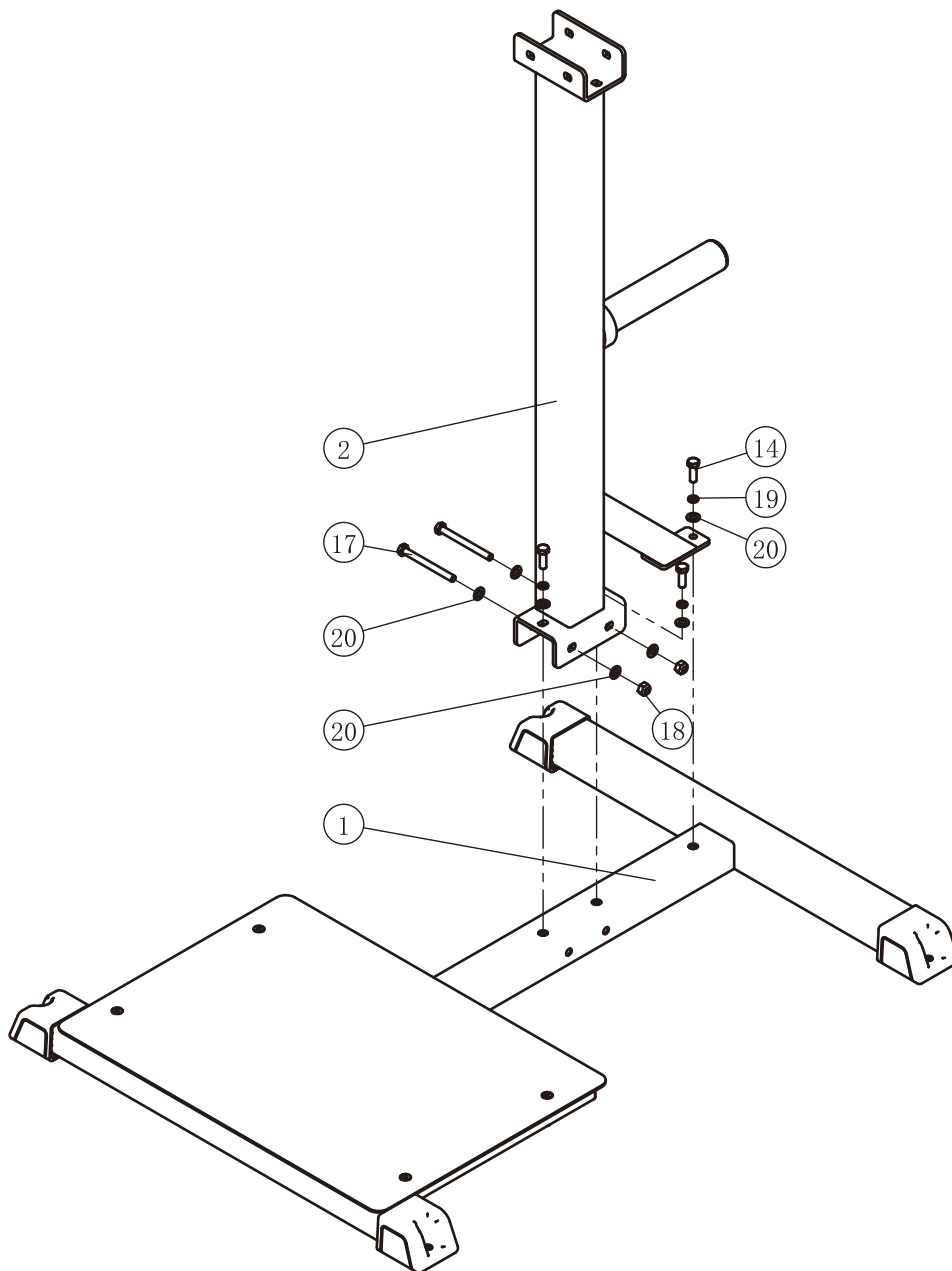

Assembly

STEP 2

Attach the Top Stand Frame ASSY (#7) to the Stand Frame ASSY (#2) using:

two M10*75 HHB (#15)

two M10*105 HHB (#17)

four M10 Nylon Lock Nut (#18)

eight $\Phi 11*\Phi 20*2$ Flat Washer (#20)

Note: Wrench Tighten Bolts and Nylon Lock Nuts.

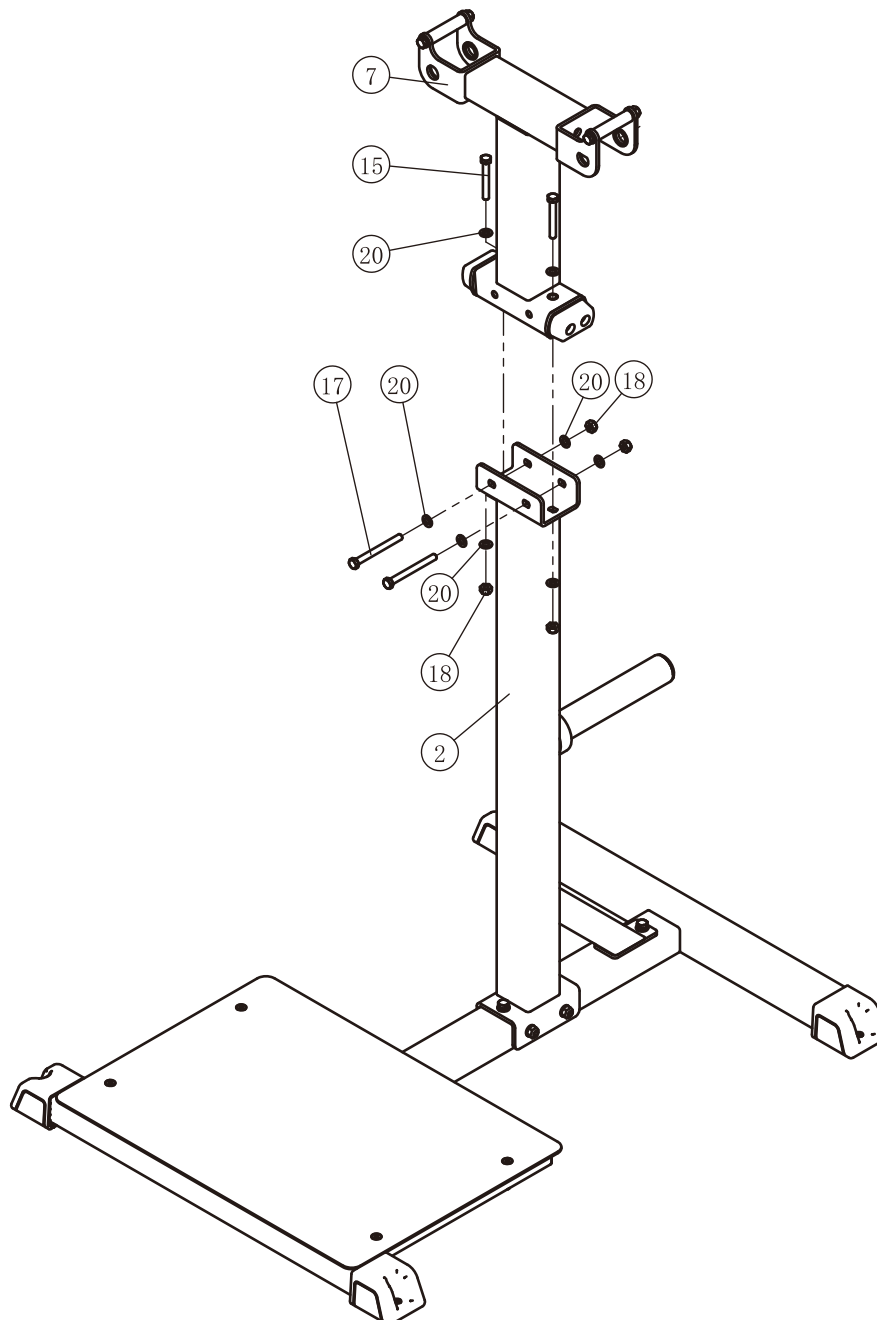

Assembly

STEP 3

1. Attach the Left Swing Frame ASSY (#3) to the Top Stand Frame ASSY (#7) using:
one $\Phi 25 \times 94$ Shaft (#8)
two $\Phi 62 \times \Phi 10.5 \times 3$ Washer (#10)
two $\Phi 60$ Cap (#11)
two M10*25 SHCS (#13)
two $\Phi 62.5$ Circle Ring (#12)
2. Attach the Right Swing Frame ASSY (#4) to the Top Stand Frame ASSY (#7) using:
one $\Phi 25 \times 94$ Shaft (#8)
two $\Phi 62 \times \Phi 10.5 \times 3$ Washer (#10)
two $\Phi 60$ Cap (#11)
two M10*25 SHCS (#13)
two $\Phi 62.5$ Circle Ring (#12)

Note: Wrench Tighten Bolts.

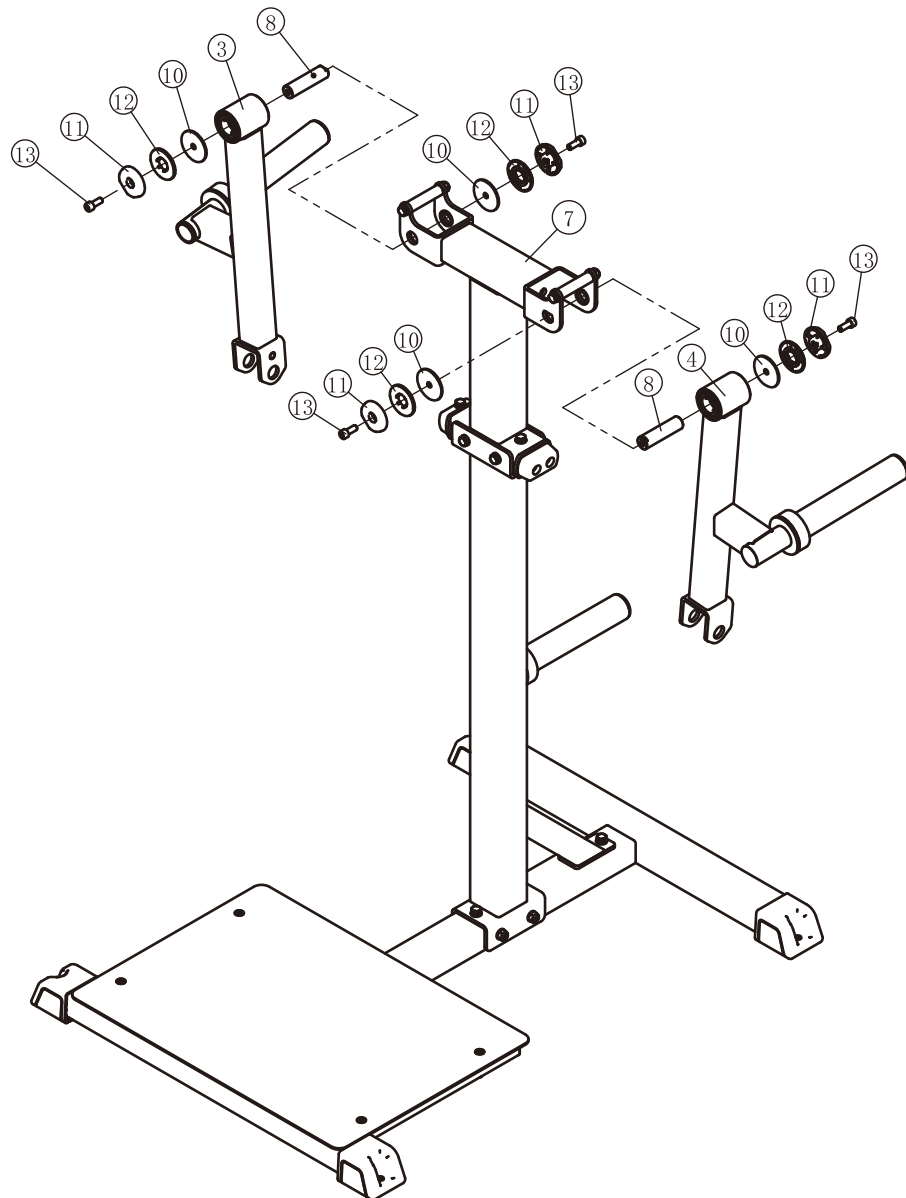

Assembly

STEP 4

1. Attach the Left Handle Frame ASSY (#5) to the Left Swing Frame ASSY (#3) using:
 - one $\Phi 25.4 \times 69$ Shaft (#9)
 - one M10 Nylon Lock Nut (#18)
 - one M10*85 HHB (#16)
 - two $\Phi 11 \times \Phi 38 \times 2$ Flat Washer (#21)
2. Attach the Right Handle Frame ASSY (#6) to the Right Swing Frame ASSY (#4) using:
 - one $\Phi 25.4 \times 69$ Shaft (#9)
 - one M10 Nylon Lock Nut (#18)
 - one M10*85 HHB (#16)
 - two $\Phi 11 \times \Phi 38 \times 2$ Flat Washer (#21)

Note: Wrench tighten bolts and Nylon Lock Nuts.

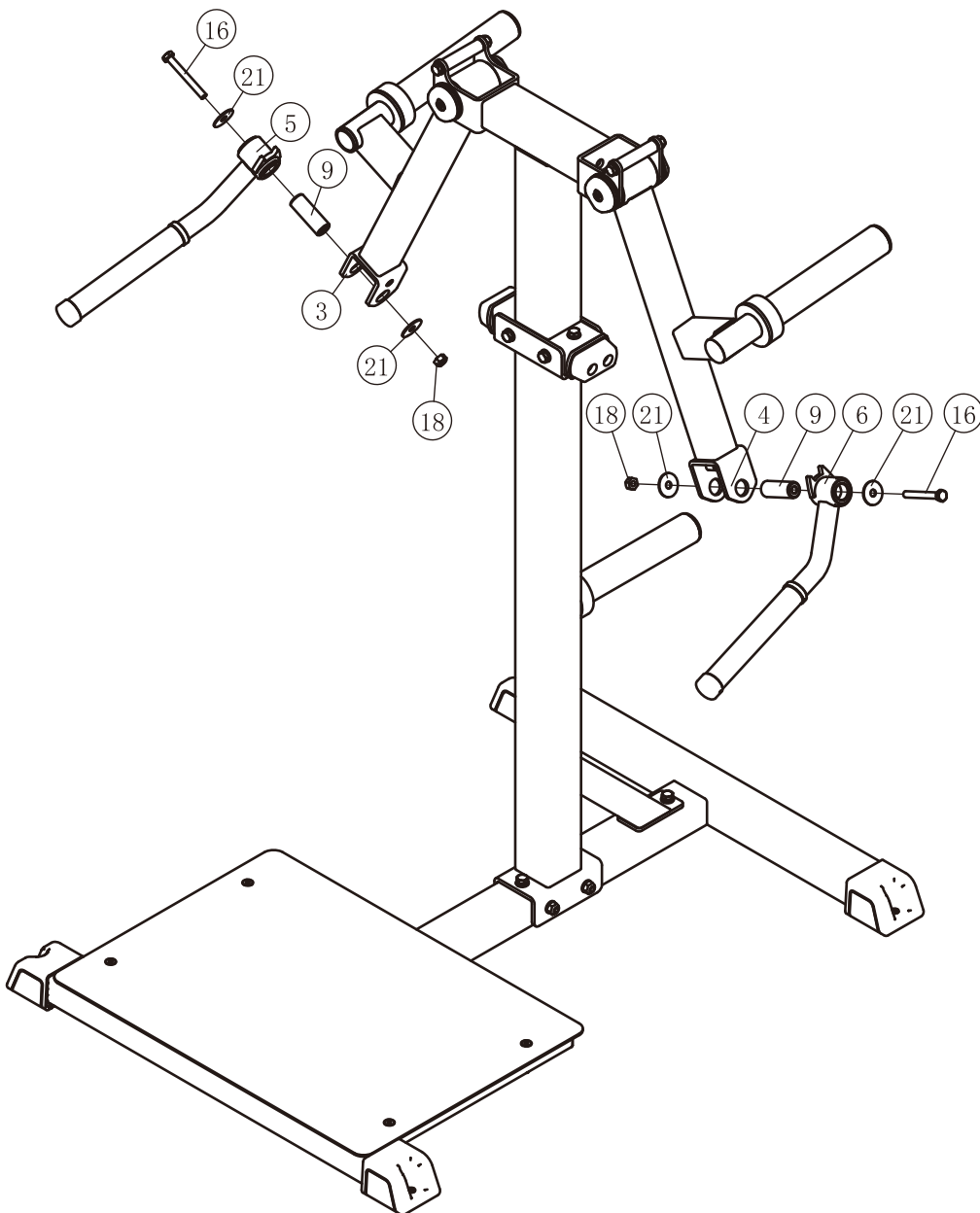

Adjust and Exercise Instruction

Weight Plate Installation Requirements

1. Please use Olympic Weight Plate which hole is greater than $\Phi 50\text{mm}$ and external diameter is less than $\Phi 450\text{mm}$.
2. The total weight of one side can not be greater than 100kg.
3. This equipment does not contains Weight Plates.

Exercise Instruction

1. Select an appropriate weight.
2. Holding handle bar rotate arms upward with a smooth.
3. Slowly return to the starting position.

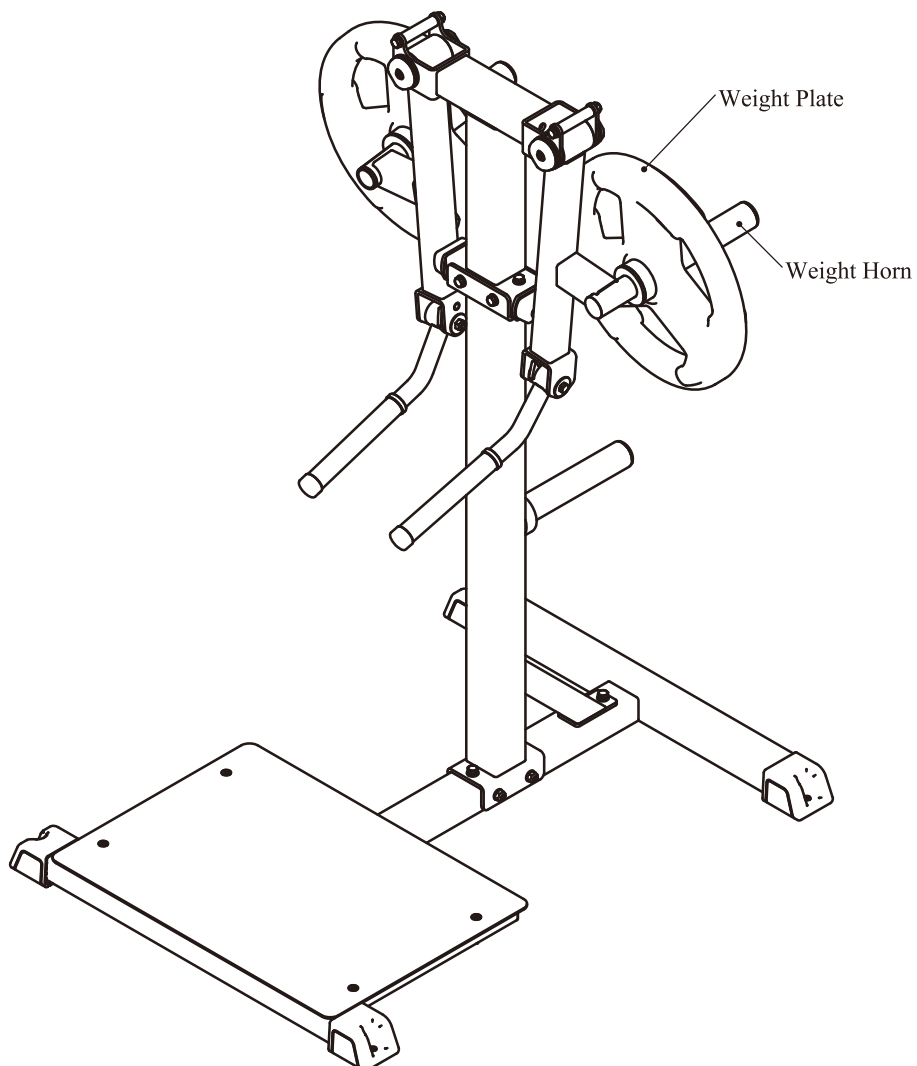

Maintenance Schedule

ROUTINE	COMMERCIAL MAINTENANCE	HOME MAINTENANCE	LATEST DATE ENTRY					
Inspect; Links, Pull Pins, Snap Locks, Swivels, Weight Stack Pins	DAILY	WEEKLY						
Clean; Upholstery	DAILY	WEEKLY						
Inspect; Cables or Belts and their tension	DAILY	WEEKLY						
Inspect; Accessory Bars, and Handles	WEEKLY	3 MONTHS						
Inspect; All Decals	WEEKLY	3 MONTHS						
Inspect; All Nuts and Bolts, Tighten if needed	WEEKLY	3 MONTHS						
Inspect; Anti-Skid Surface	WEEKLY	3 MONTHS						
Clean & Lubricate; Guide Rods with a Teflon (PTFE) based lubricant (Superlube)	MONTHLY	3 MONTHS						
Lubricate; Seat Sleeves, Turcite Bushings, Linear Bearing	MONTHLY	3 MONTHS						
Clean and Wax; All Glossy Finishes	6 MONTHS	YEARLY						
Repack with Grease; Linear Bearings	6 MONTHS	YEARLY						
Replace; Cables, Belts and Connecting Parts	YEARLY	3 YEARS						

Your equipment comes with a commercial maintenance decal. For personal, in home use, please follow the home maintenance schedule listed above.

General Maintenance Information

Links, Pull-Pins, Snap Hooks, Swivels, Weight Stack Pins:

- * Check all pieces for signs of visible wear or damage.
- * Check springs in snap hooks and pull-pins for proper tension and alignment.
- * If the spring sticks or has lost its rigidity, replace it immediately.

Upholstery:

- * To ensure prolonged upholstery life and proper hygiene, all upholstered pads should be wiped down with a damp cloth after every workout.
- * Periodically take the time to use a mild soap or an approved vinyl upholstery cleaner to deter the onset of cracking or drying. Avoid using any abrasive cleaners or cleaners not intended for use on vinyl.
- * Replace ripped or worn upholstery immediately.
- * Keep sharp or pointed objects clear of all upholstery.

Decals:

- * Inspect and familiarize yourself with any safety warnings or other user information posted on each decal.

Nuts and Bolts:

- * Inspect all nuts and bolts for any loosening and tighten if needed.
- * Go through a re-tightening sequence periodically to ensure that all hardware is tensioned proper.

Anti-Skid Surfaces:

- * These surfaces are designed to supply secure footing and need to be replaced if they appear worn or become slippery.

Belts and Cables:

- * We use only high quality belt, and mil-spec cables.
- * Visually inspect the belts and cables for fraying, cracking, peeling or discoloration.
- * While the machine is not in use, carefully run your fingers along the belt or cable to feel for thinning or bulging areas.
- * Replace belts and cables immediately at the first signs of damage or wear. Do not use equipment until belts or cables have been replaced.

Belt and Cable Tension:

- * Referring to the Owners Manual, when belts or cables are used check all bolts attachments to be sure they are properly attached.
- * Check slack in cables and re-adjust cable tension if needed.

Seat Sleeves, Guide Rods:

- * Wipe down adjusting tubes with a dust free rag before applying lubricant.
- * Lubricate seat sleeves and Guide Rods with a Silicon or Teflon based lubricant spray.

Linear Bearings:

- * Referring to the Owners Manual carefully disassemble the bearing from its housing and place a finger full of light grease (lithium, super lube, etc.) into the inside of the bearing. Using your finger, press the grease into the ball-bearings and their tracks. repeat until the ball-bearing tracks are full of grease. Insert the shaft back into the bearing and wipe off excess grease.

PLEASE KEEP THIS FOR YOUR RECORDS

Weight Training Tips

Use this manual to guide you through the basic exercises you can perform on your equipment. To gain maximum results and avoid possible injury, consult a fitness professional to develop your complete exercise program.

Always consult your physician before starting any exercise program.

To be successful in your exercise program, it is important to develop an understanding of the basic principles of strength training. Now that you have your equipment, it is only natural that you want to get started immediately. First, determine a set of realistic goals and objectives for yourself. By deciding on an exercise plan that is right for you prior to starting, you will contribute significantly to your success.

Warm up properly before engaging in weight resistance training. Stretching, yoga, jogging, calisthenics or other cardiovascular exercise can help prepare your body for the heavier workload of lifting weights.

Learn how to perform the exercise correctly before using heavy weight. Correct form is important to avoid injury and to ensure that you work the proper muscle groups.

Know your limitations. If you are new to weight training or are embarking on an exercise regimen after a long layoff, start slowly and build foundational strength over a longer period of time.

Pay attention to your breathing. Exhale when you exert is a general rule of thumb. Never hold your breath.

