

Инструкция

Мультистанция Body Solid FUSION F500/2

Полезные ссылки:

[Мультистанция Body Solid FUSION F500/2 - смотреть на сайте](#)

[Мультистанция Body Solid FUSION F500/2 - читать отзывы](#)

Body-Solid

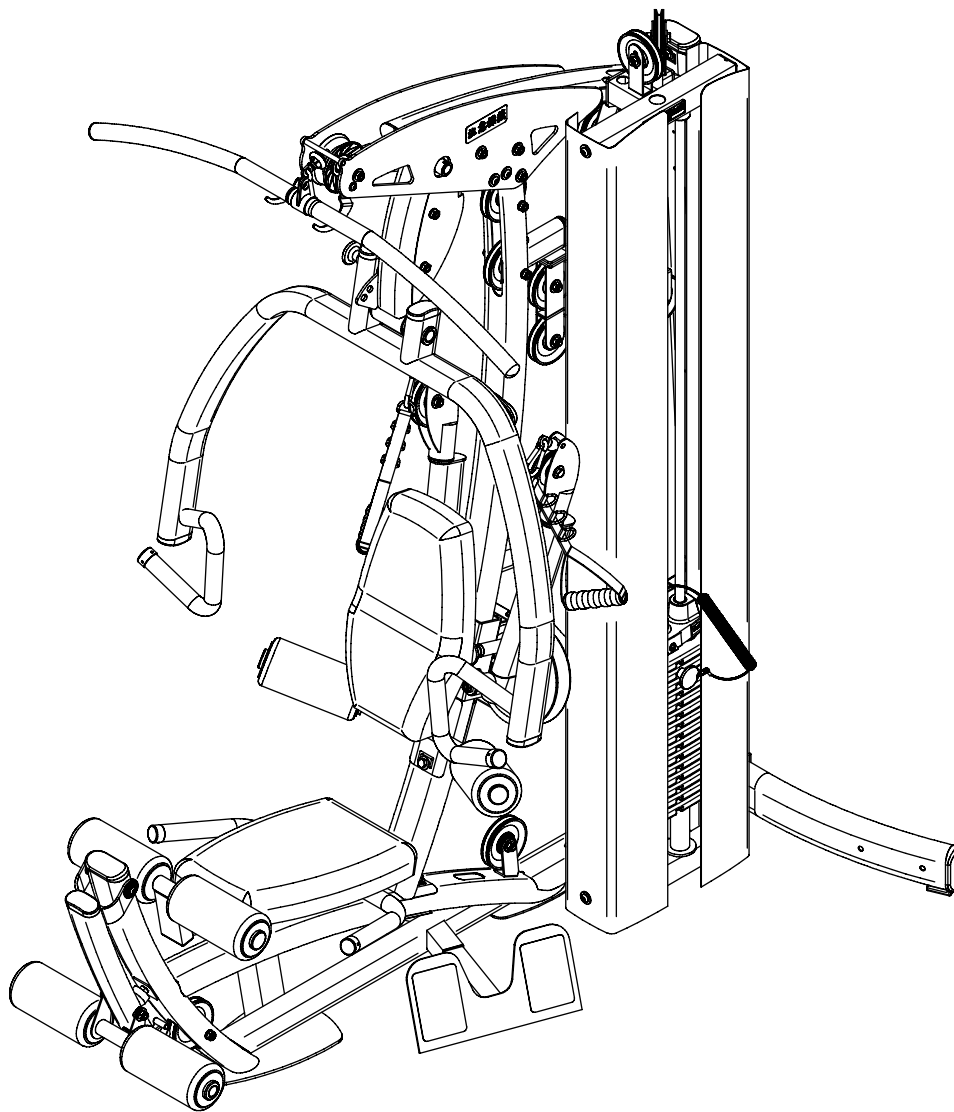

BODY-SOLID, Inc
1900 S.Des Plaines Ave.
Forest Park, IL 60130 USA
Phone:(708)427-3555
Fax:(708)427-3556
www.bodysolid.com

F500 OWNER'S MANUAL

F500 ASSEMBLY INSTRUCTIONS

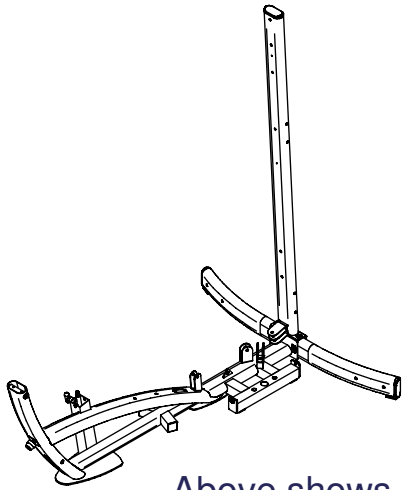

Above shows STEP1
assembled and completed

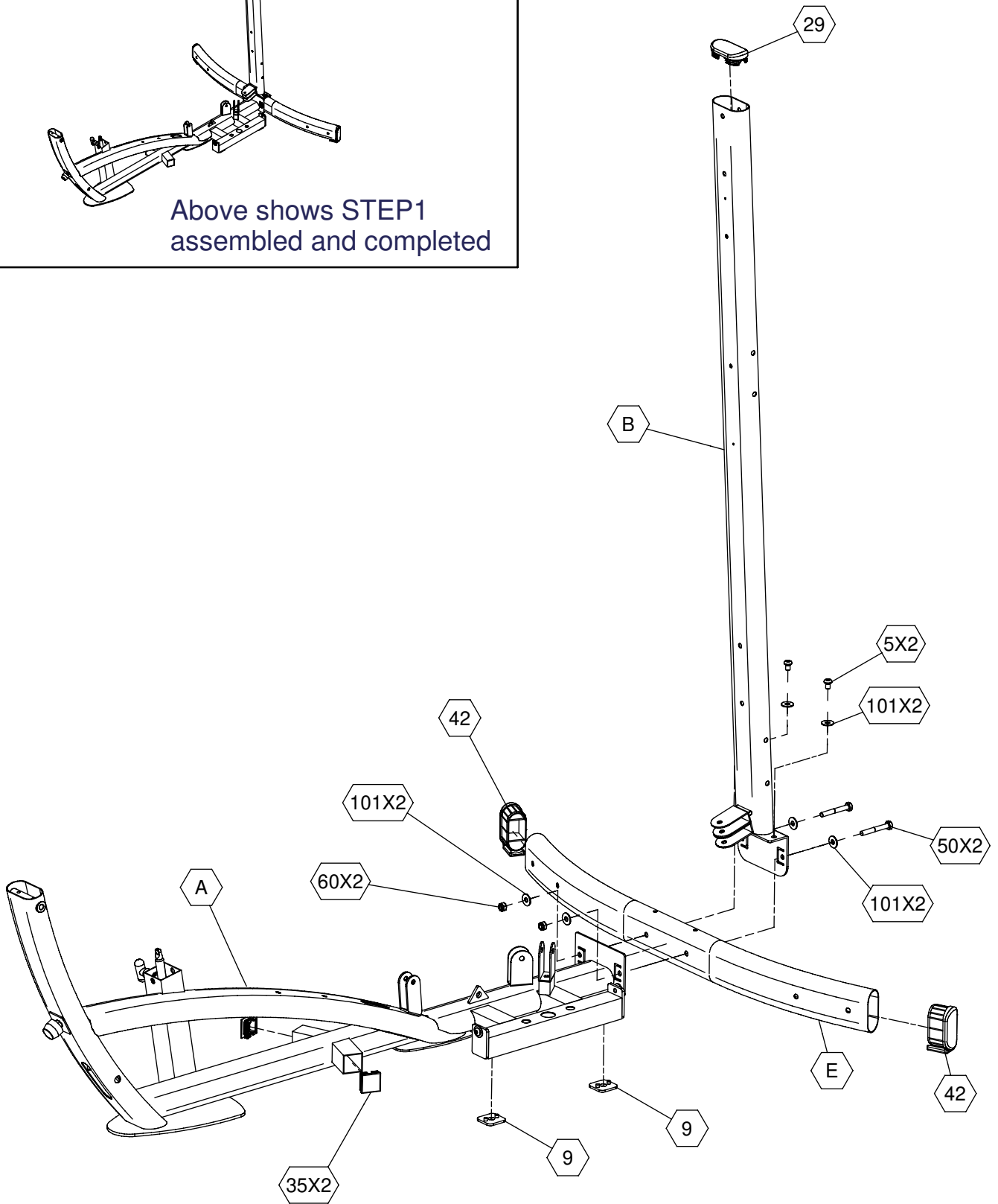

F500 ASSEMBLY INSTRUCTIONS

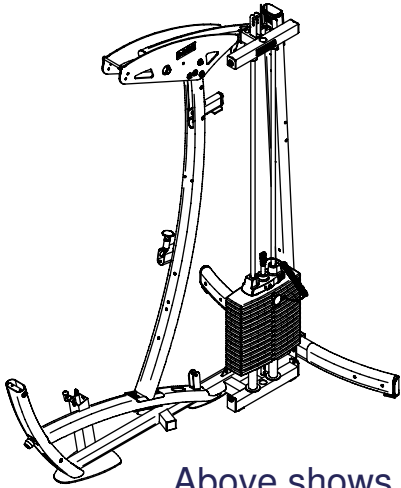

Above shows STEP2
assembled and completed

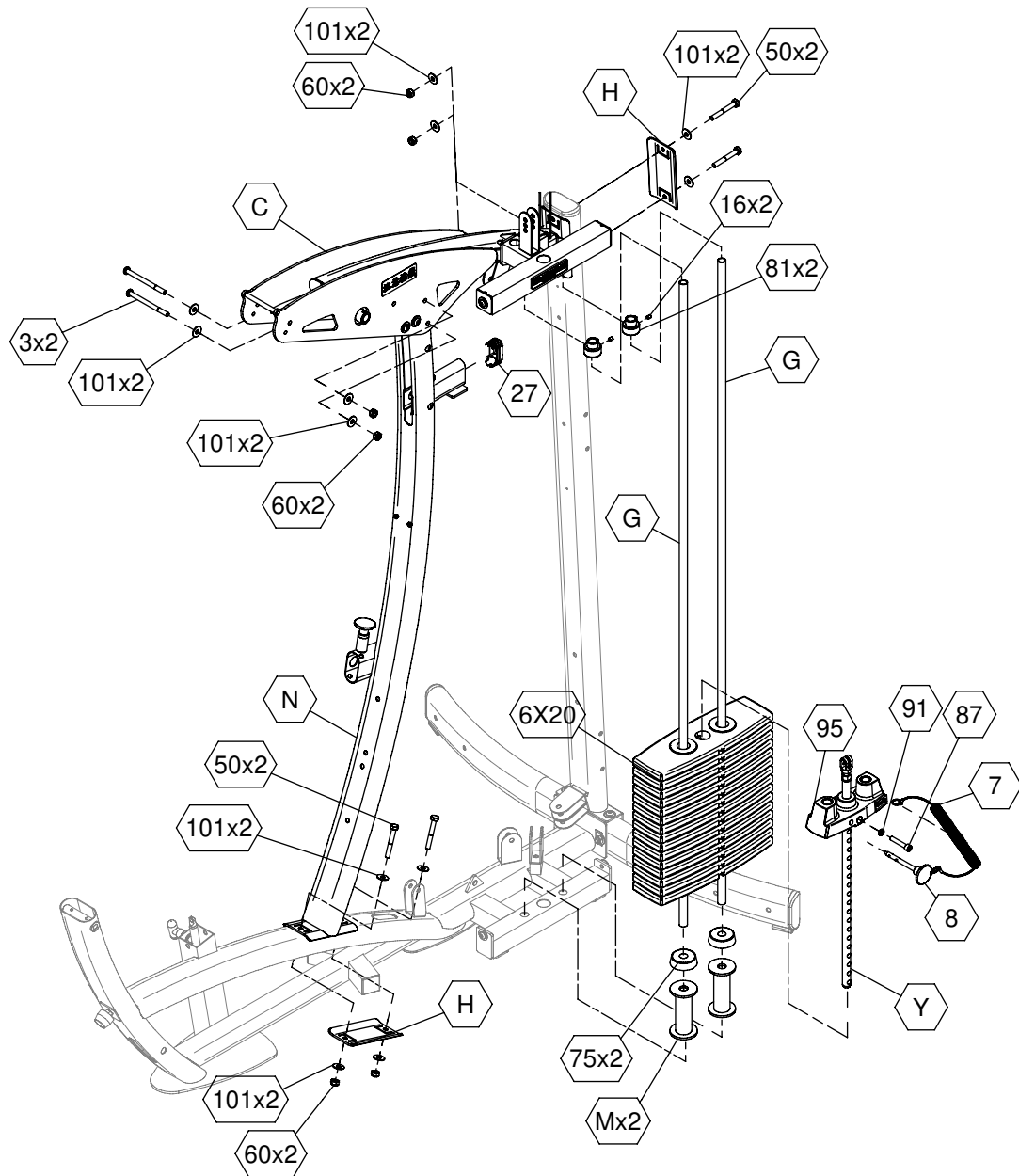

F500 ASSEMBLY INSTRUCTIONS

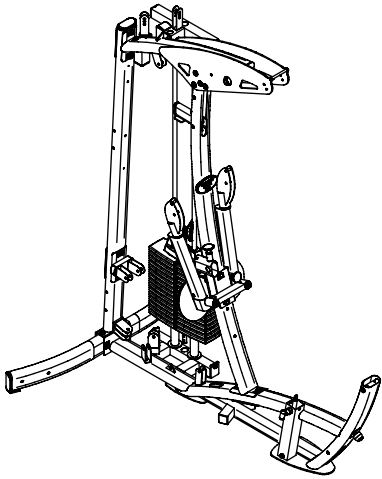

Above shows STEP3 assembled and completed

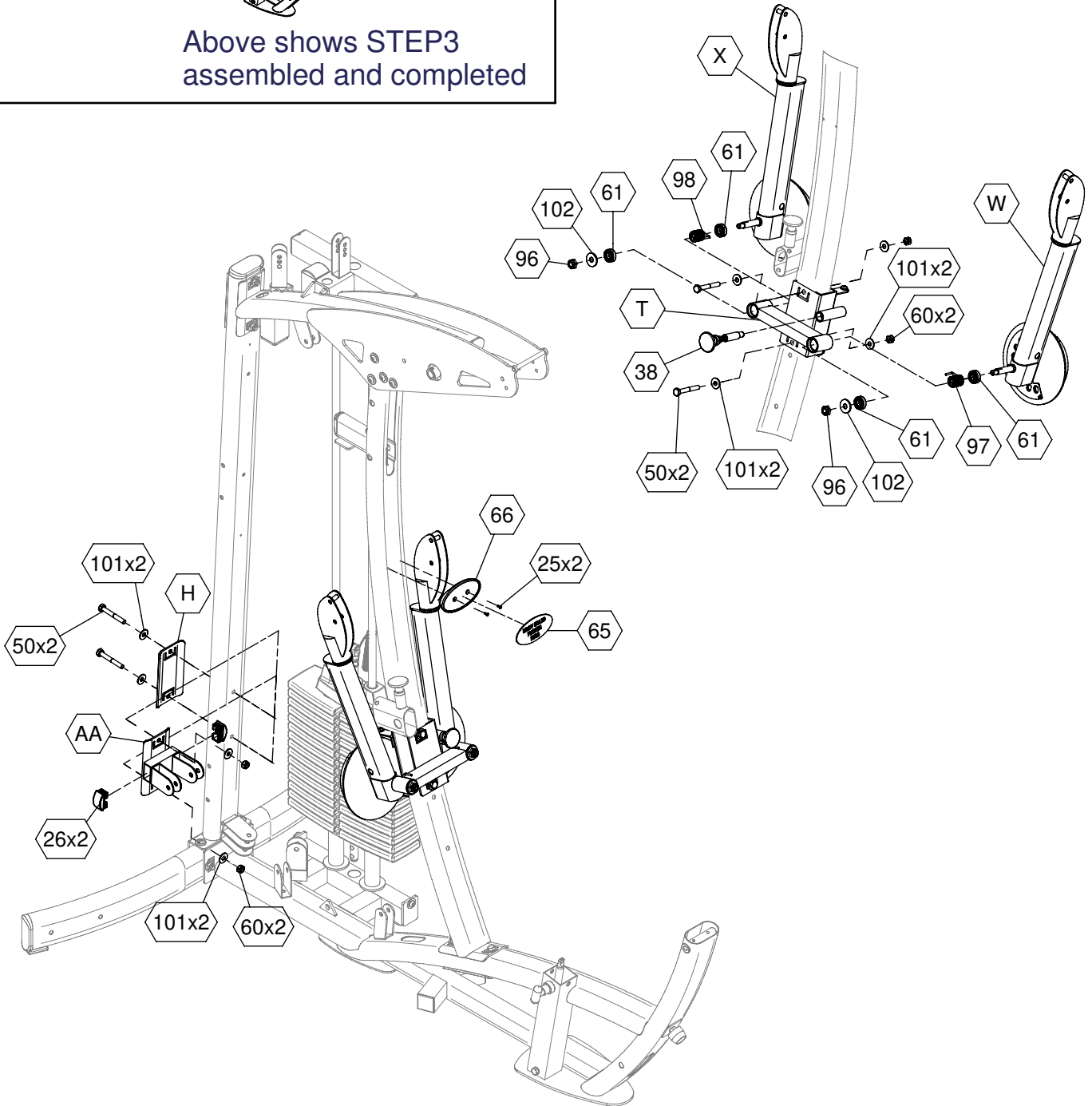

F500 ASSEMBLY INSTRUCTIONS

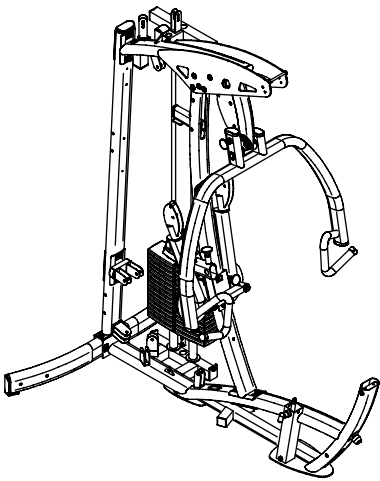

Above shows STEP4 assembled and completed

DETAIL VIEW

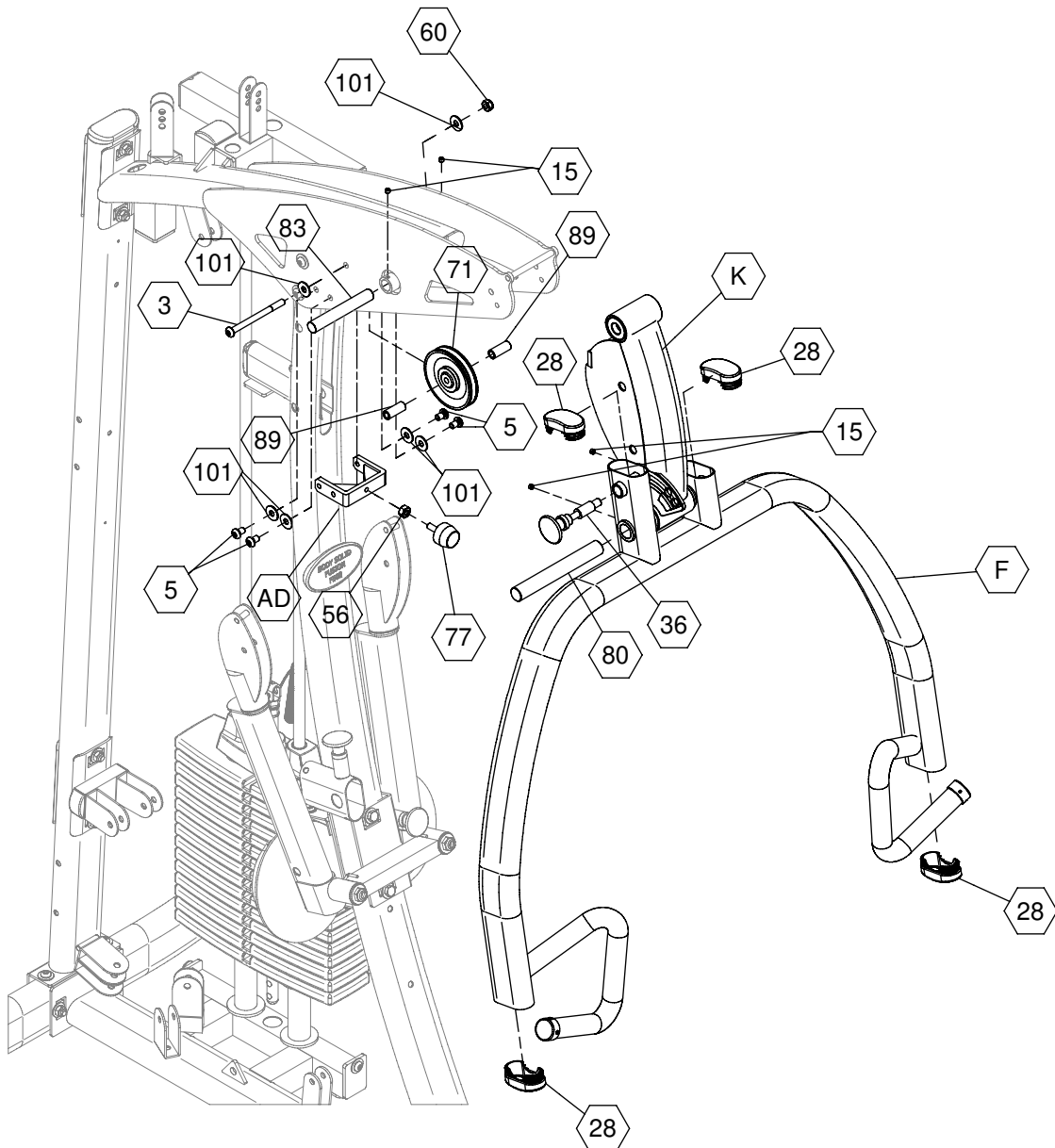
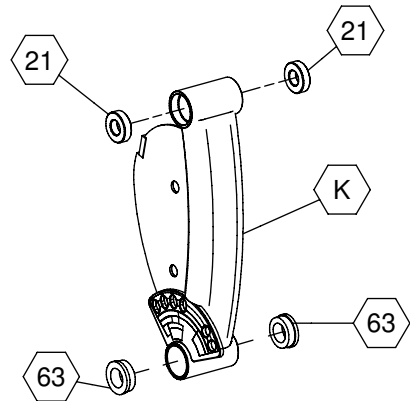

F500 ASSEMBLY INSTRUCTIONS

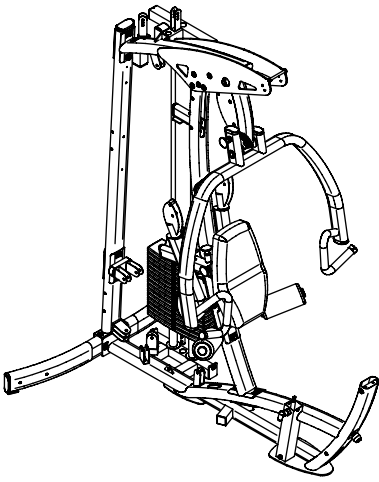

Above shows STEP5
assembled and completed

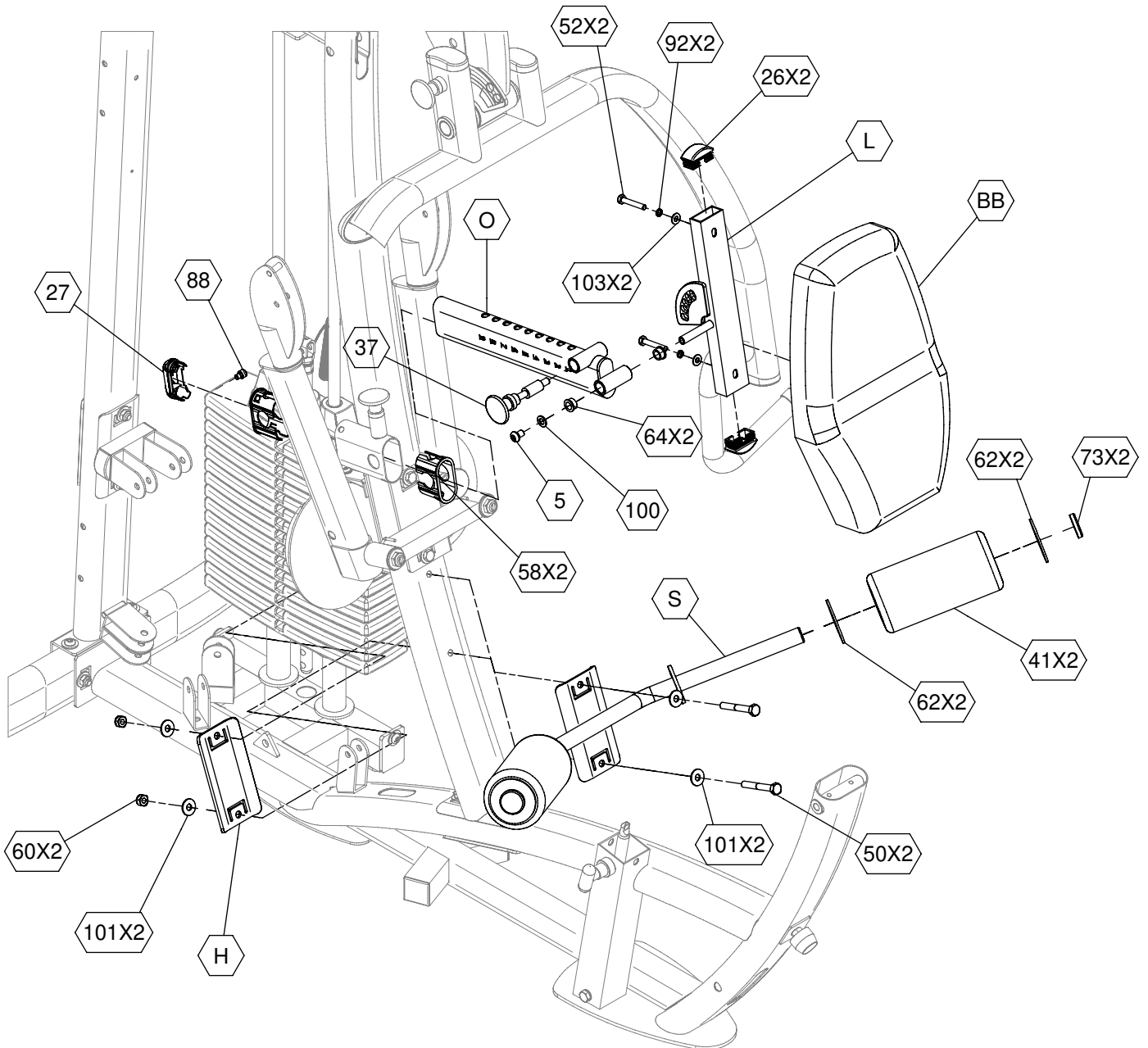

F500 ASSEMBLY INSTRUCTIONS

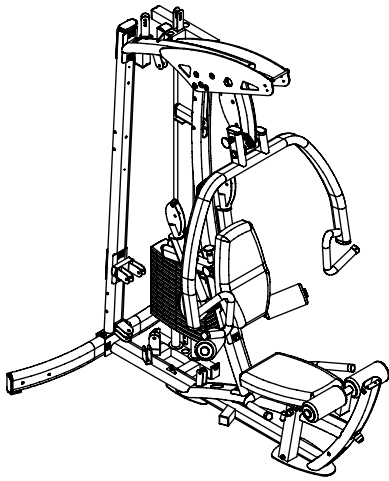

Above shows STEP6
assembled and completed

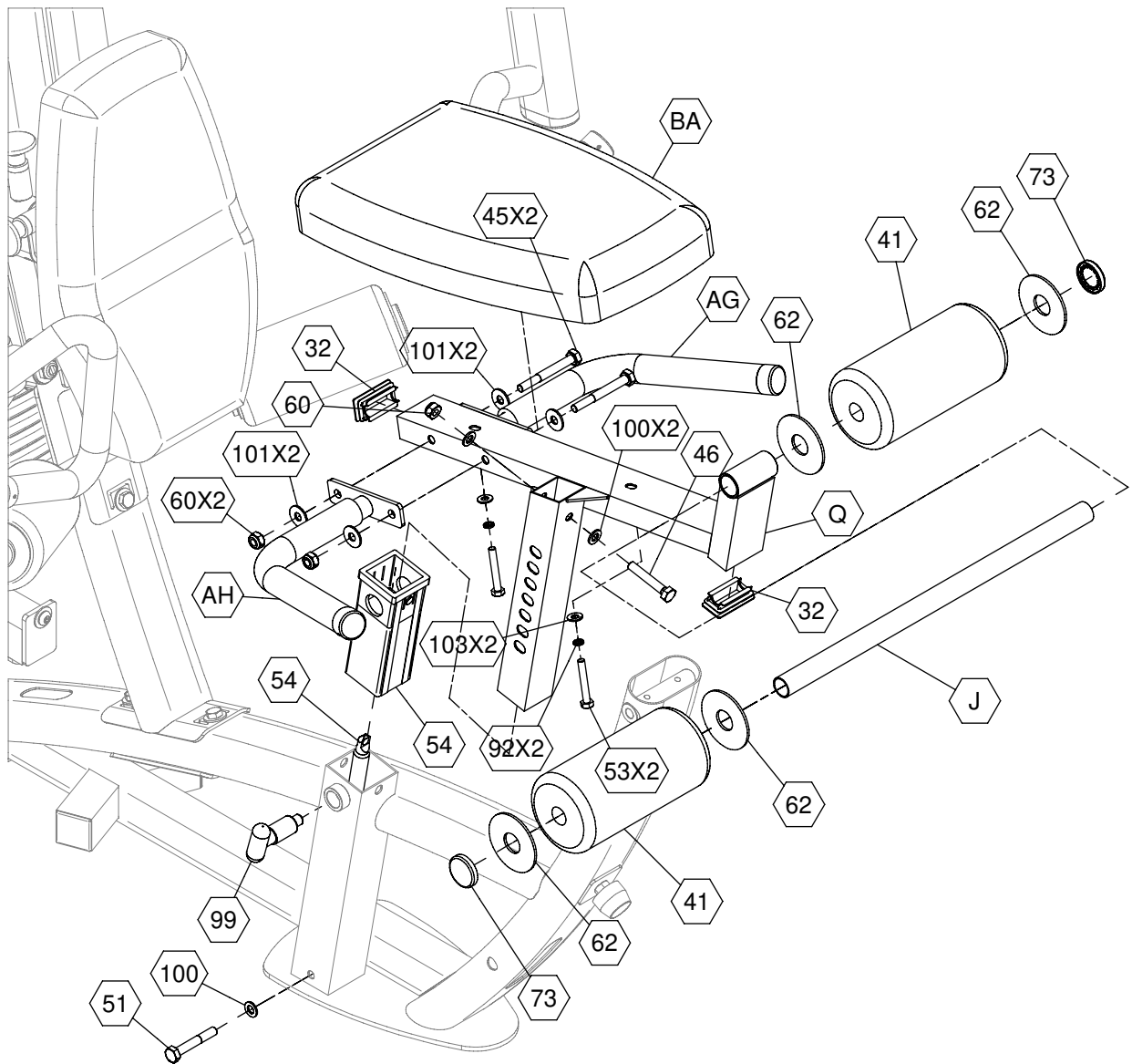

F500 ASSEMBLY INSTRUCTIONS

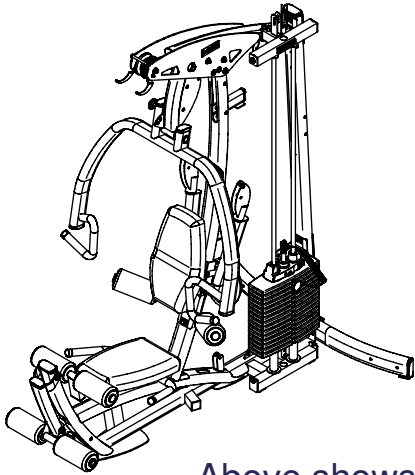

Above shows STEP7
assembled and completed

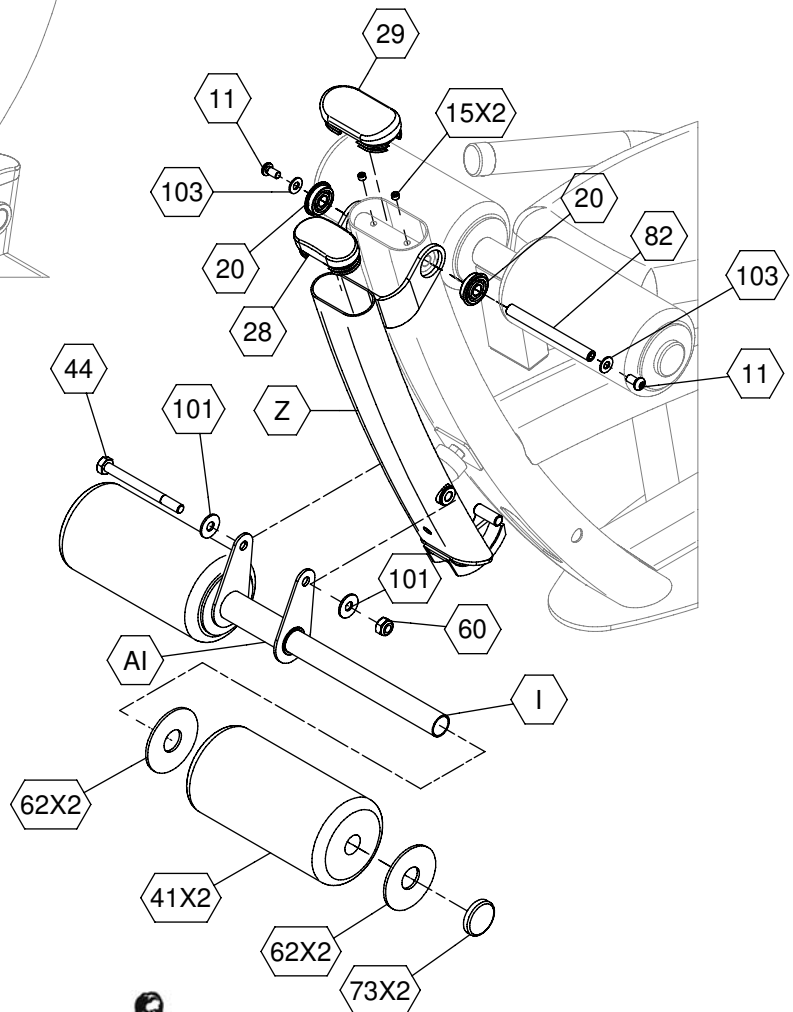
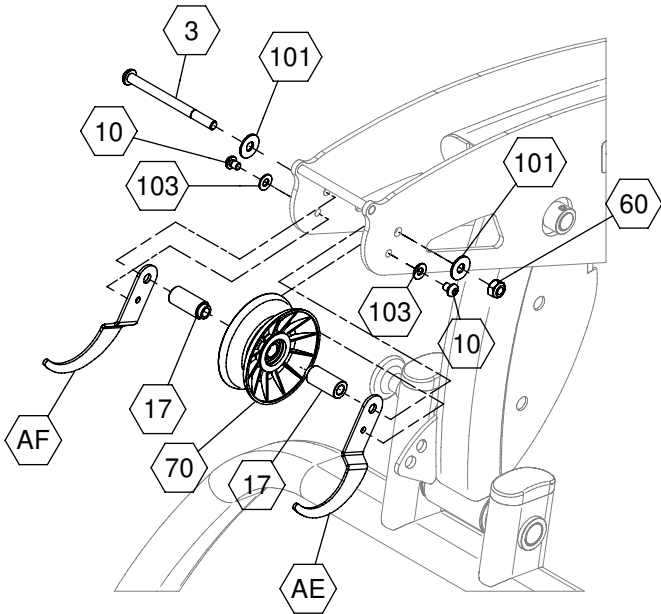

F500 ASSEMBLY INSTRUCTIONS

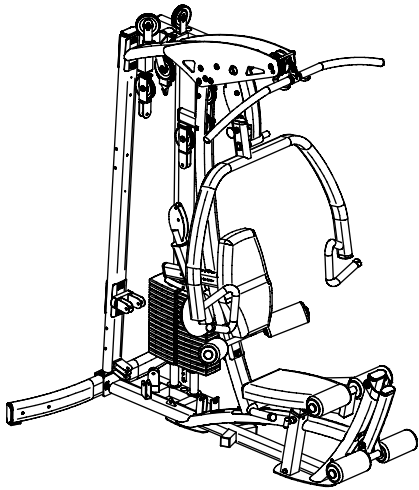

Above shows STEP8 assembled and completed

Step 01.

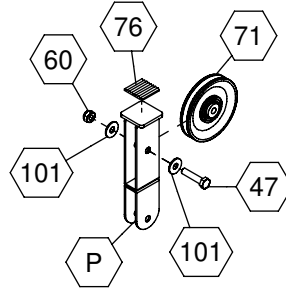

Step 02.

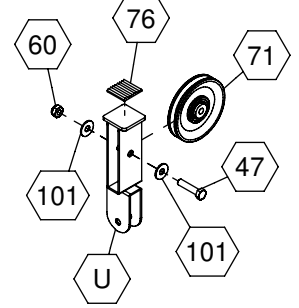

Step 03.

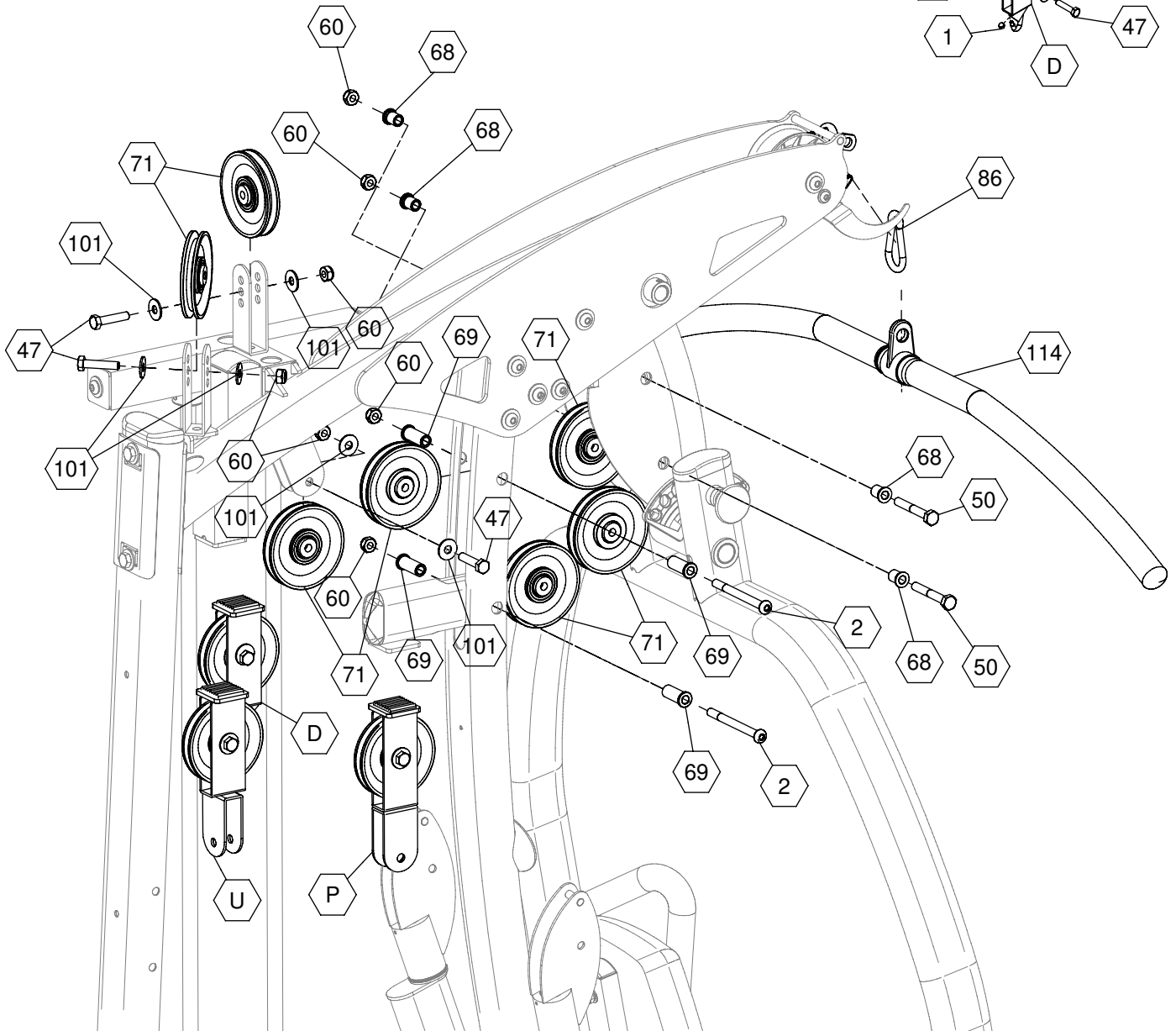
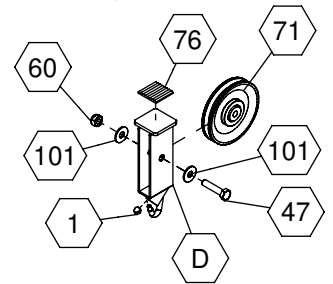

Cable to constitute illustration

LAT PULLDOWN CABLE (106)

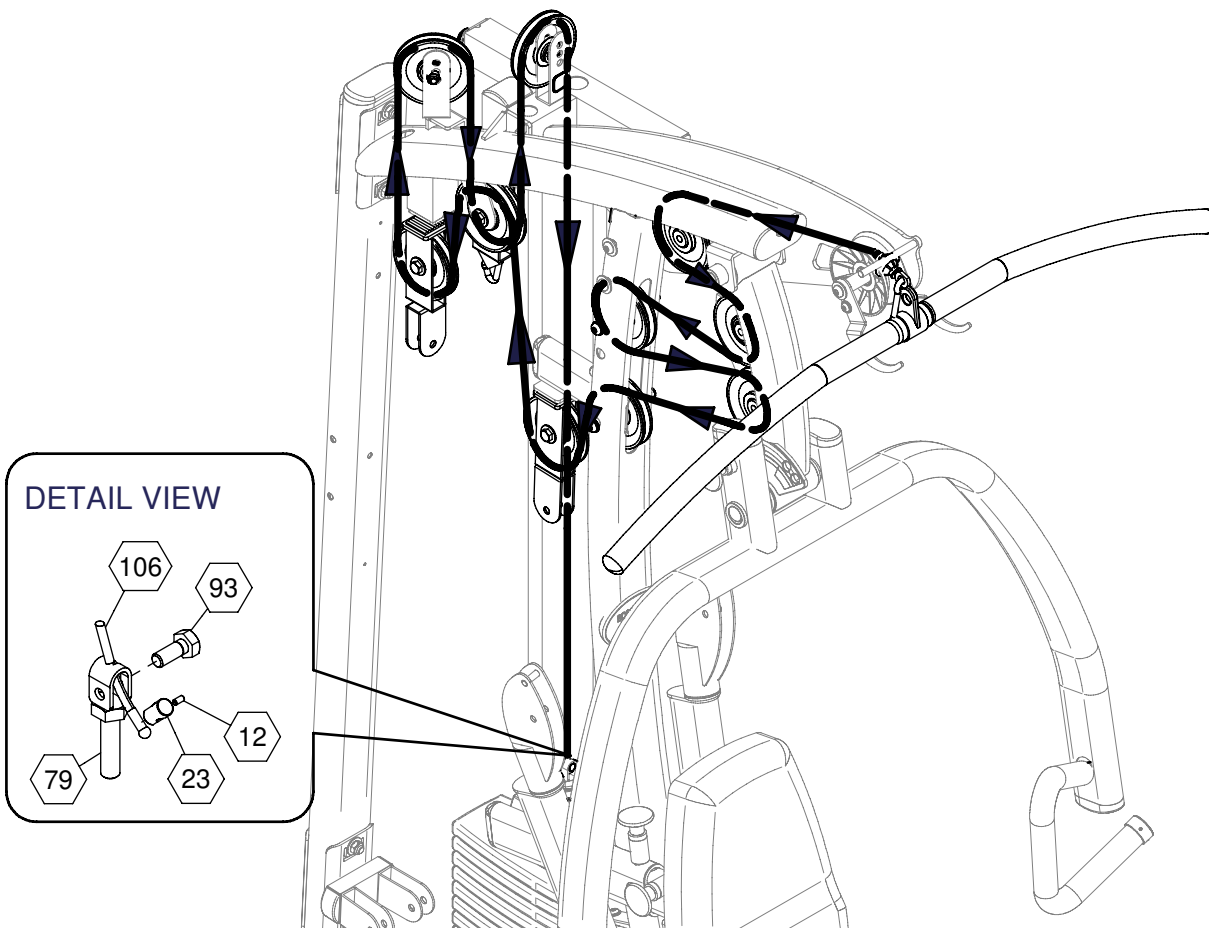
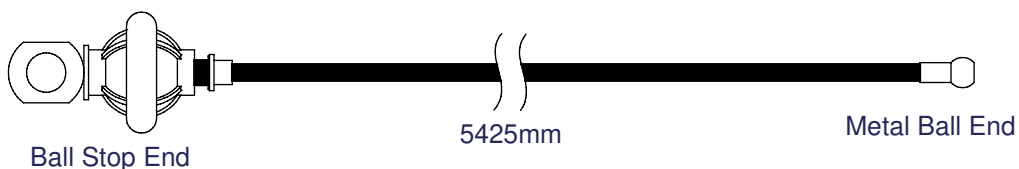

F500 ASSEMBLY INSTRUCTIONS

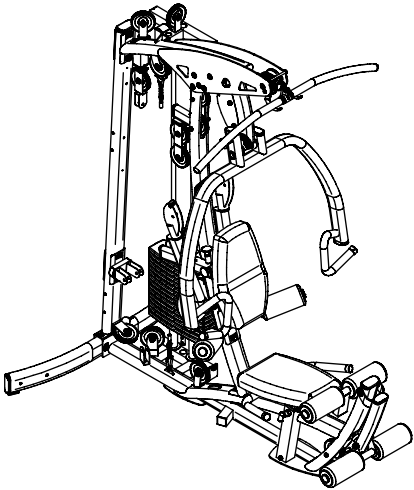

Above shows STEP9 assembled and completed

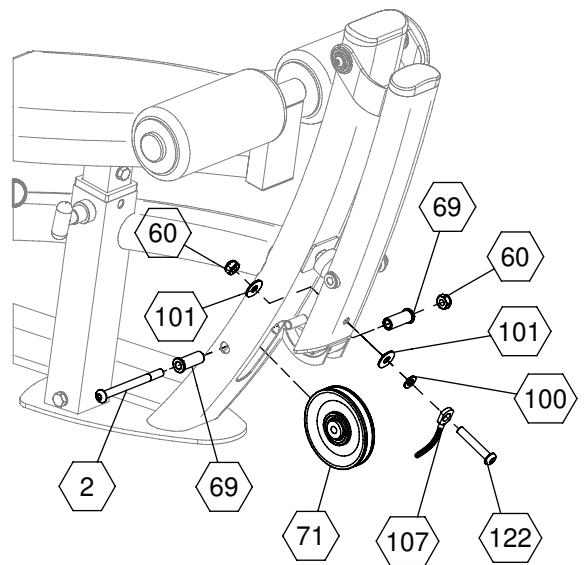
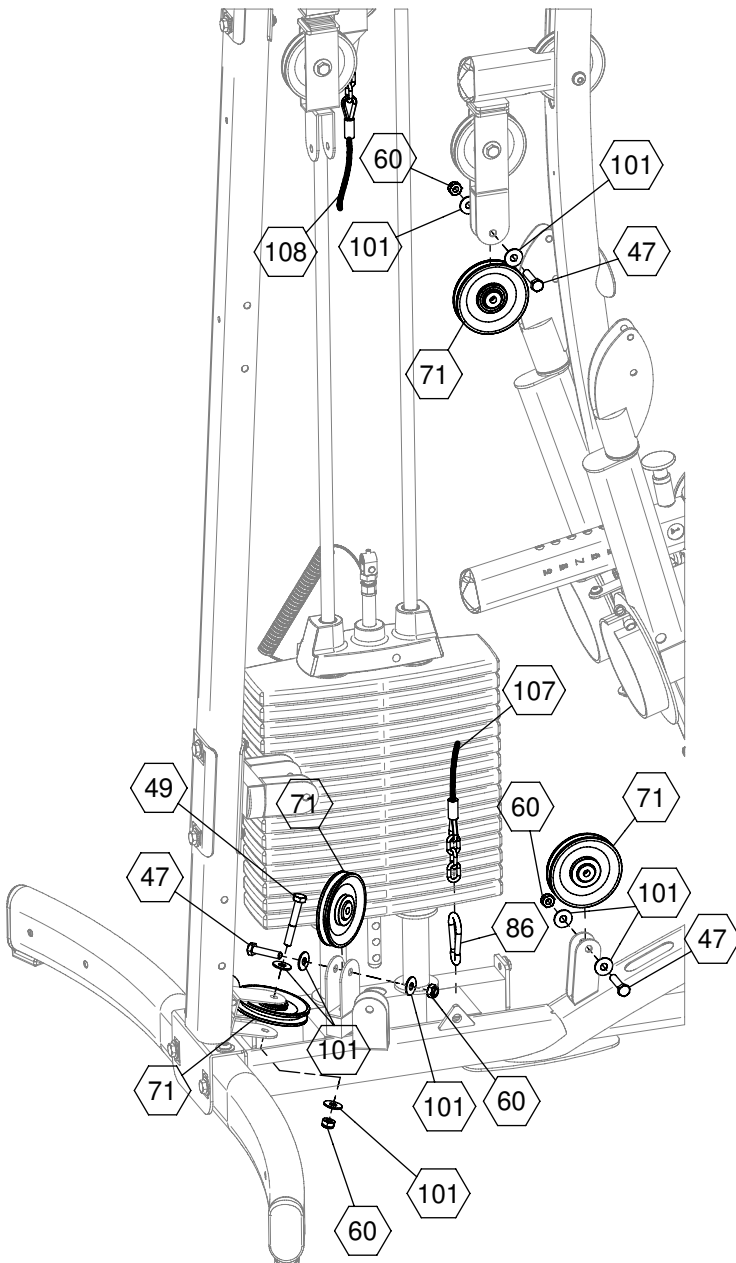

F500 ASSEMBLY INSTRUCTIONS

Cable to constitute illustration

LEG EXTENSION CABLE (107)



LEFT ATTACHMENT CABLE (108)

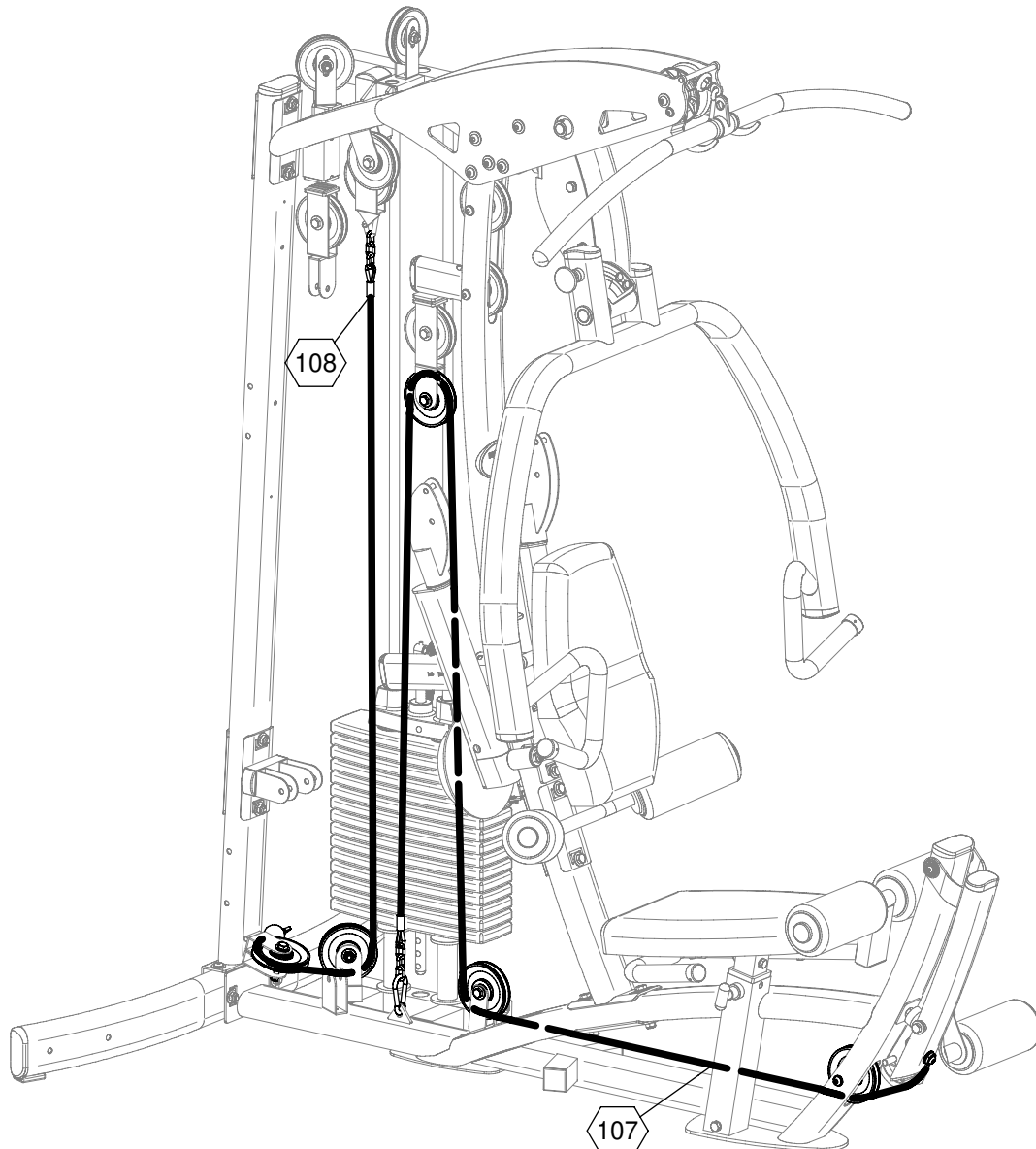
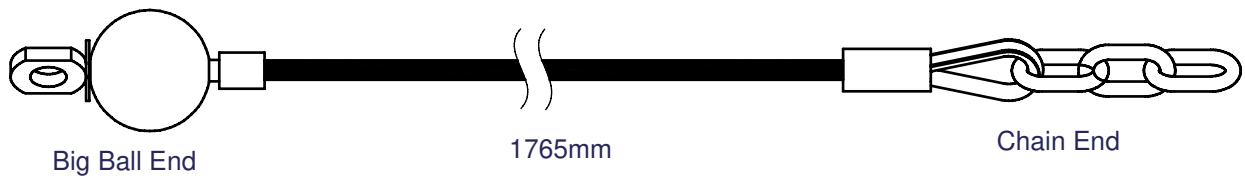

F500 ASSEMBLY INSTRUCTIONS

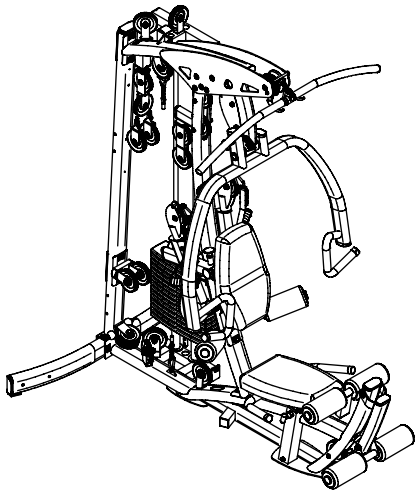

Above shows STEP10 assembled and completed

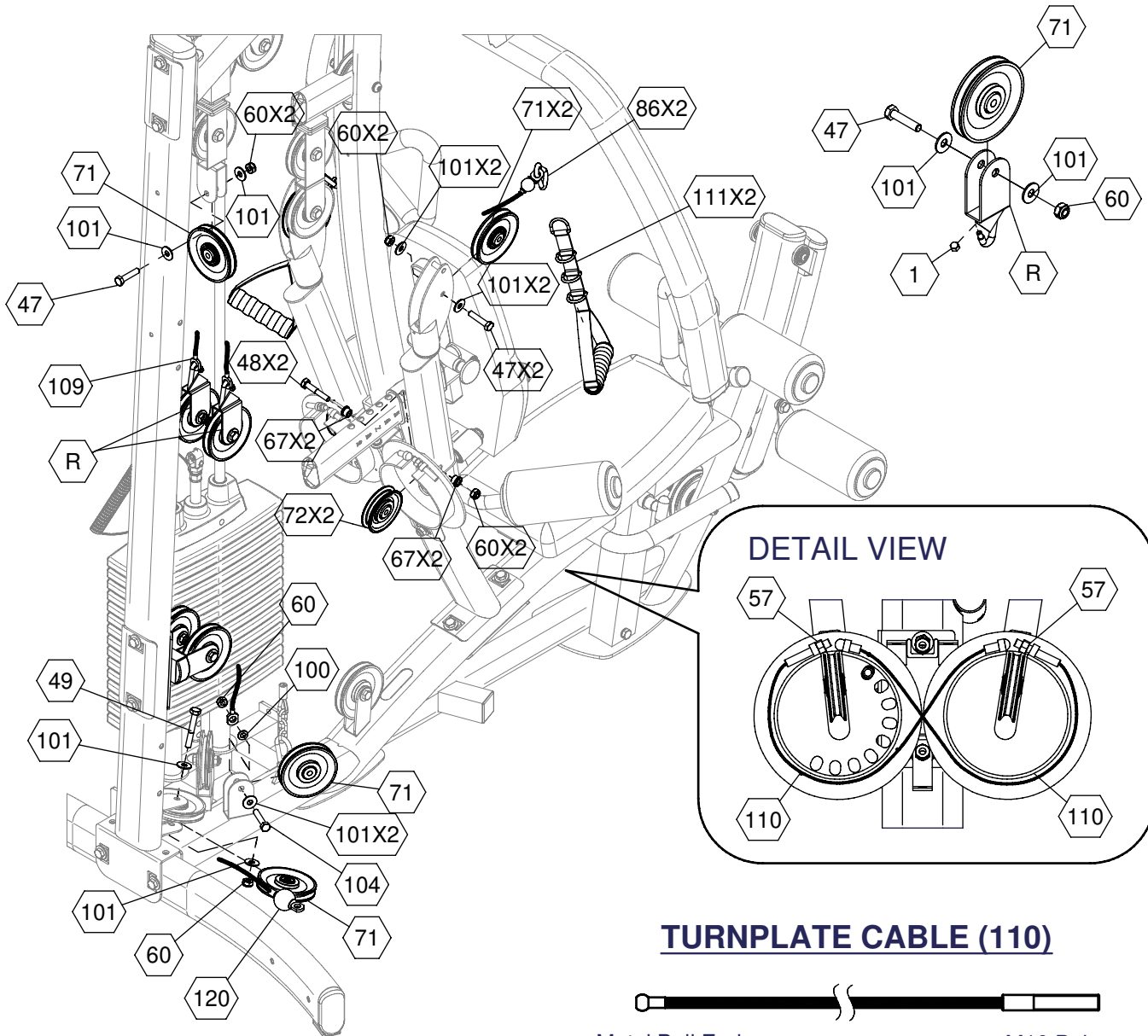
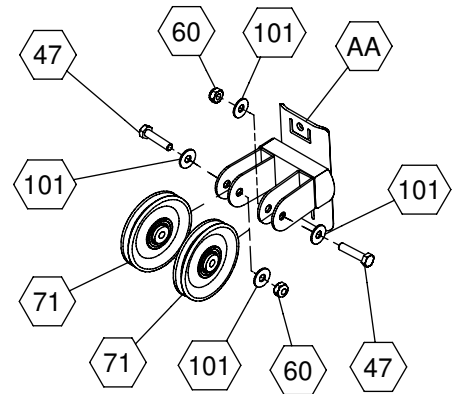

TURNPLATE CABLE (110)

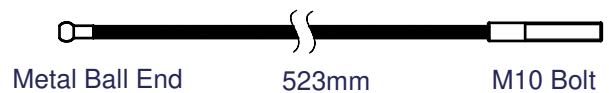

F500 ASSEMBLY INSTRUCTIONS

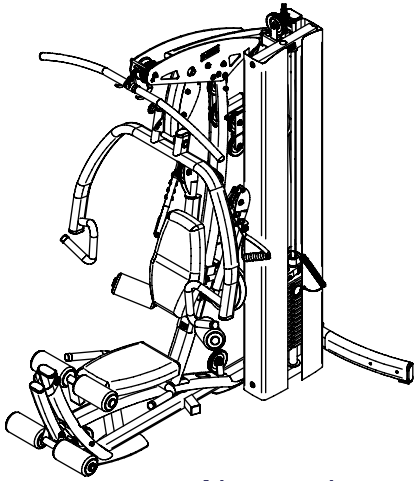

Above shows STEP11 assembled and completed

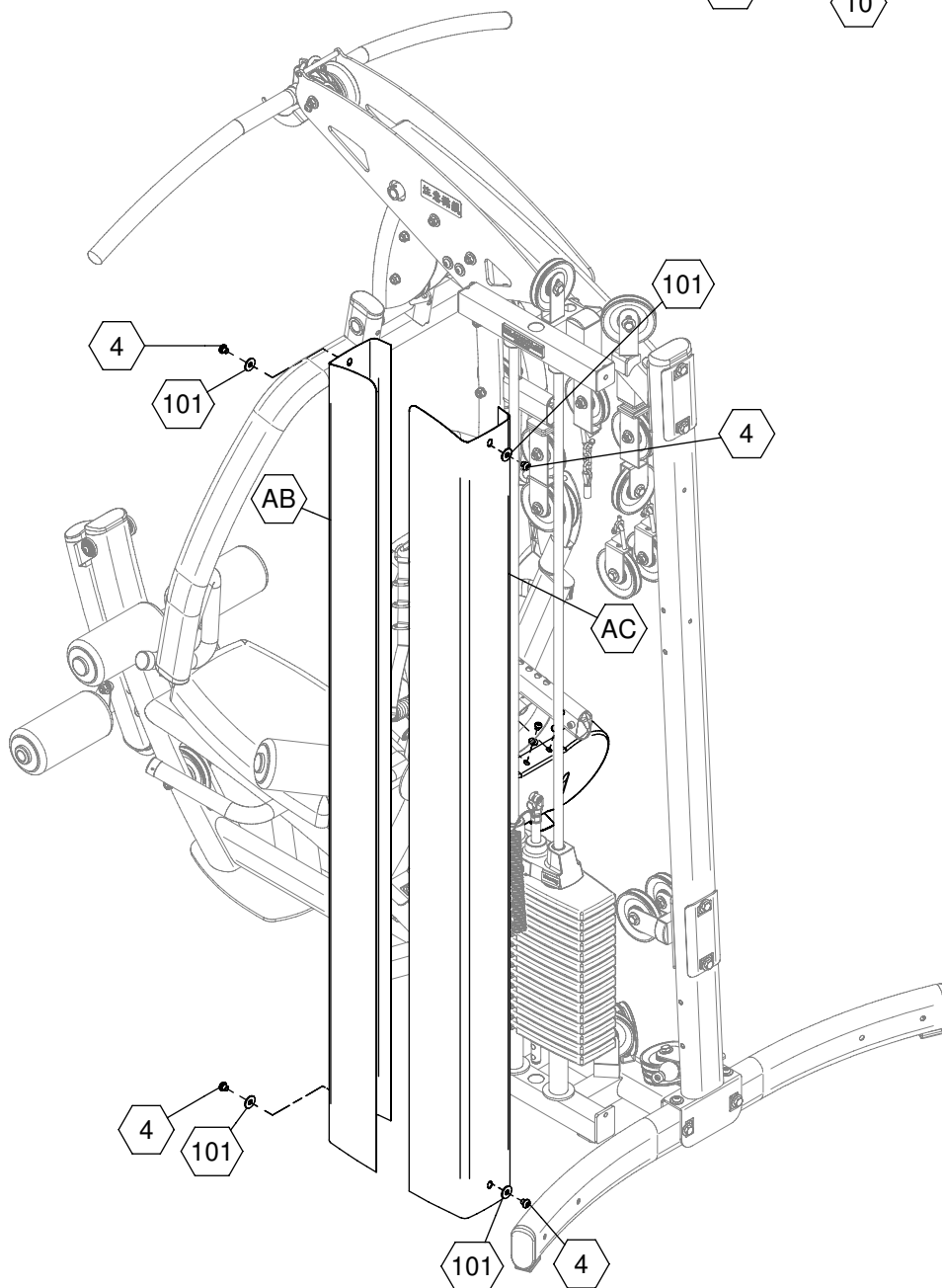
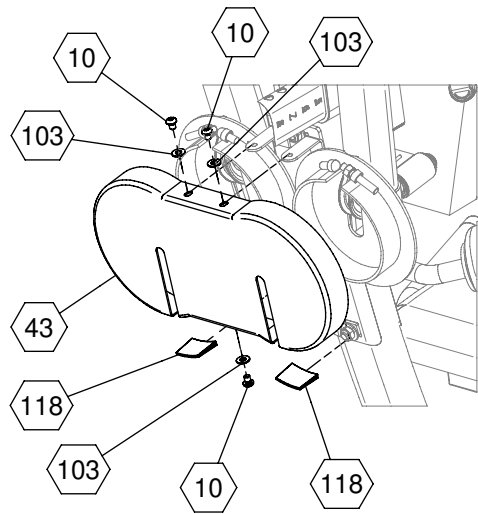

F500 ASSEMBLY INSTRUCTIONS

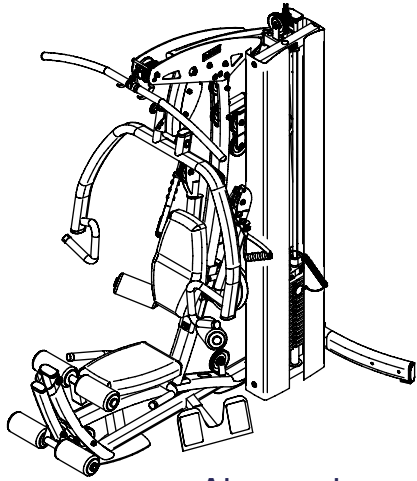

Above shows STEP12
assembled and completed

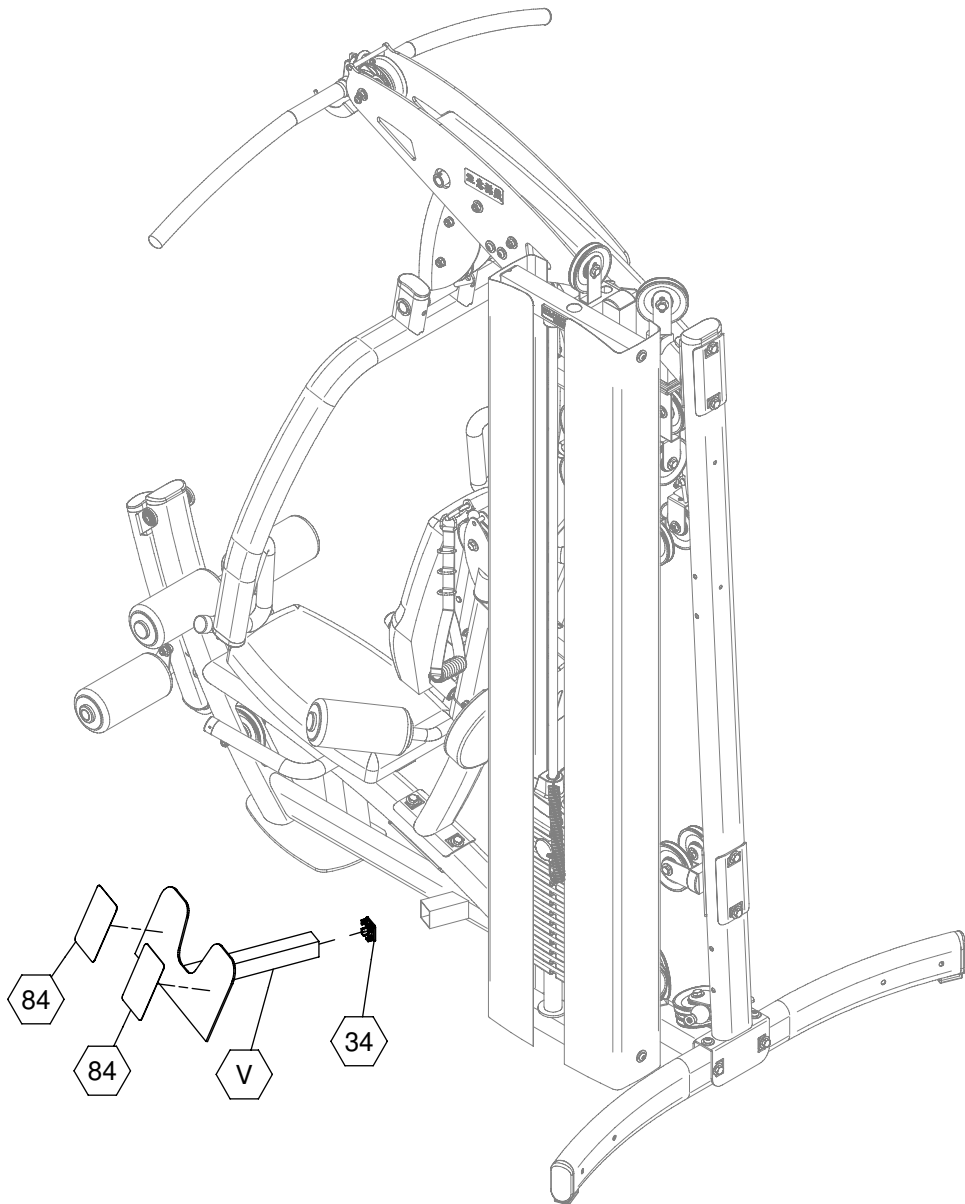

F500 Mainframe Parts List

KEY#	QTY	PART#	DESCRIPTION
A	1		MAIN BASE FRAME
B	1		REAR UPRIGHT FRAME
C	1		MAIN TOP FRAME
D	1		PULLY HOLDER WITH STOP
E	1		REAR LEG
F	1		SEATED PRESS ARM
G	2		CHROME GUIDE ROD
H	4		CONTOURED BACKING PLATE 170L
I	1		ROLLER BAR (1"X535L)
J	1		ROLLER BAR (1"X500L)
K	1		PRESS ARM SUPPORT
L	1		PIVOTING BACK REST FRAME
M	2		WEIGHT STACK SUPPORT FRAME
N	1		MAIN FRONT FRAME
O	1		BACK PAD ADJUSTER
P	1		HOLDER FOR DOUBLE PARALLEL PULLIES
Q	1		ADJUSTABLE SEAT FRAME
R	2		PULLY HOLDER
S	1		LEG HOLD DOWN FRAME
T	1		FUNCTIONAL TRAINING ARMS PIVOT BASE
U	1		HOLDER FOR DOUBLE CROSSED PULLIES
V	1		SIDE LEG HOLD DOWN FRAME
W	1		FUNCTIONAL TRAINING ARM (left side)
X	1		FUNCTIONAL TRAINING ARM (right side)
Y	1		SELECTOR ROD
Z	1		LEG EXTENSION ARM
AA	1		FUNCTIONAL TRAINING ARMS REAR PULLY SUPPORT
AB	1		FRONT SHROUD
AC	1		BACK SHROUD
AD	1		PRESS ARM STOP
AE	1		LAT PULL DOWN BAR HOLDER (left side)
AF	1		LAT PULL DOWN BAR HOLDER (right side)
AG	1		LEFT ARMREST
AH	1		RIGHT ARMREST
AI	1		PIVOTING BUSHING

Pads List

KEY#	QTY	PART#	DESCRIPTION
BA	1		SEAT PAD
BB	1		BACK PAD

Part numbers are required when ordering parts.

F500 Hardware List

KEY#	QTY	PART#	DESCRIPTION
1	3		ACORN CAP NUT M6 preinstalled
2	3		ALLEN HEAD BOLT M10 X 115L PARTIAL THREAD
3	4		ALLEN HEAD BOLT M10 X 125L PARTIAL THREAD
4	4		ALLEN HEAD BOLT M10 X 10L FULL THREAD
5	7		ALLEN HEAD BOLT M10 X 15L FULL THREAD
6	20		WEIGHT PLATES
7	1		WEIGHT STACK LANYARD
8	1		WEIGHT STACK PIN Φ 10 X 138L
9	2		WEIGHT STACK SHIM 50 X 50
10	5		ALLEN HEAD BOLT M8 X 10L FULL THREAD
11	2		ALLEN HEAD BOLT M8 X 15L FULL THREAD
12	1		ALLEN SCREW M4 X 8L FULL THREAD
13	2		ALLEN SCREW M5 X 10L FULL THREAD - preinstalled
14	10		ALLEN SCREW M5 X 5L FULL THREAD
15	6		ALLEN SCREW M8 X 6L FULL THREAD
16	2		ALLEN SCREW M8 X 8L FULL THREAD
17	2		BEARING BUSHING Φ 20 X 46L
18	2		BEARING BUSHING Φ 37 ID X Φ 42 OD - preinstalled
19	2		BEARING BUSHING Φ 37 ID X Φ 50 OD - preinstalled
20	2		BEARING Φ 12 ID X Φ 32 OD - preinstalled
21	2		BEARING Φ 20 ID X Φ 42 OD - preinstalled
22	4		BEARING Φ 30 ID X Φ 37 OD - preinstalled
23	1		CABLE END SHAFT
24	2		CHROME COLLAR Φ 26 ID X Φ 35 OD
25	2		TAPERED CROSSHEAD SCREW M5 X 10L FULL THREAD
26	4		CONVEX END CAP 1" X 2"
27	2		CONVEX END CAP 30 X 70
28	5		CONVEX END CAP 40 X 80
29	4		CONVEX END CAP 50 X 100
30	1		CONVEX END CAP 50 X 50
31	3		CROSSHEAD SCREW M4 X 6L FULL THREAD
32	2		FLAT END CAP 30 X 60
33	1		CHROME COLLAR Φ 26 ID X Φ 38 OD
34	1		FLAT END CAP 40 X 40
35	2		FLAT END CAP 45 X 45
36	1		FLAT HEAD POP PIN 124L
37	1		FLAT HEAD POP PIN 124L (back pad angle adjuster)
38	1		FLAT HEAD POP PIN 138L
39	1		FLAT HEAD POP PIN 96L (back pad position adjuster)
40	2		FOAM GRIP Φ 34 OD X 545L (seated press)
41	6		FOAM ROLLER 4" X 8"
42	2		FOOT CAP 50 X 100
43	1		FUNCTIONAL TRAINING COVER
44	1		HEX HEAD BOLT M10 X 110L PARTIAL THREAD
45	2		HEX HEAD BOLT M10 X 85L PARTIAL THREAD
46	1		HEX HEAD BOLT M10 X 60L PARTIAL THREAD
47	16		HEX HEAD BOLT M10 X 45L PARTIAL THREAD
48	2		HEX HEAD BOLT M10 X 55L PARTIAL THREAD
49	1		HEX HEAD BOLT M10 X 70L PARTIAL THREAD

Part numbers are required when ordering parts.

F500 Hardware List (continued)

KEY#	QTY	PART#	DESCRIPTION
50	12		HEX HEAD BOLT M10 X 75L PARTIAL THREAD
51	1		HEX HEAD BOLT M10 X 65L PARTIAL THREAD
52	2		HEX HEAD BOLT M8 X 50L PARTIAL THREAD
53	2		HEX HEAD BOLT M8 X 55L PARTIAL THREAD
54	1		HYDRAULIC SEAT ADJUSTER-preinstalled
55	1		JAM NUT 1/2"
56	2		JAM NUT 3/8"
57	2		JAM NUT M10
58	2		NYLON BUSHING 40 X 80
59	1		NYLON BUSHING 60 X 60
60	46		NYLON LOCK NUT M10
61	4		BEARING Φ 15 ID X Φ 32 OD
62	12		NYLON WASHER 3"
63	2		OILITE BUSHING 1"ID X 45 OD - preinstalled
64	2		OILITE BUSHING 1/2" ID X 21 OD - preinstalled
65	1		NAMEPLATE
66	1		NAMEPLATE SEAT
67	4		PULLY SPACER Φ 16 X 12L
68	6		PULLY SPACER Φ 16 X 21.5L
69	6		PULLY SPACER Φ 16 X 42L
70	1		PULLY Φ 110
71	25		PULLY Φ 110
72	2		PULLY Φ 90
73	6		ROLLER END CAP
74	2		ROUND END CAP 1"
75	2		RUBBER DONUT Φ 63.5
76	3		RUBBER PAD 38 X 40
77	2		RUBBER STOP 58.5L (3/8" bolt)
78	1		SELECTOR ROD (20 selector holes)
79	1		SELECTOR ROD TOP BOLT
80	1		SHAFT 1" X 196L
81	2		SHAFT COLLAR
82	1		SHAFT Φ 12 X 122L
83	1		SHAFT Φ 20 X 138L
84	1		RUBBER PAD 95 X 140
85	2		FOAM GRIP Φ 34 OD X 340L
86	4		SNAP LINK
87	1		SOCKET HEAD BOLT 3/8" X2" PARTIAL THREAD
88	1		SOCKET HEAD BOLT M8 X 10L FULL THREAD
89	2		SPACER SLEEVE Φ 16 X 39L
90	1		SPRING LOCK WASHER 1/2"
91	1		SPRING LOCK WASHER 3/8"
92	4		SPRING LOCK WASHER M8
93	1		HEX HEAD BOLT M10 X 25L FULL THREAD
94	58		STEEL BALL (Φ 3) - preinstalled
95	1		TOP PLATE 10lbs
96	2		NYLON LOCK NUT M12
97	1		TORSIONAL SPRING (left)- preinstalled
98	1		TORSIONAL SPRING (right)- preinstalled

Part numbers are required when ordering parts.

F500 Hardware List (continued)

KEY#	QTY	PART#	DESCRIPTION
99	1		T-SHAPED POP PIN
100	4		WASHER M10 X Φ 19
101	86		WASHER M10 X Φ 27
102	2		WASHER M12 X Φ 34
103	11		WASHER M8 X Φ 18
104	1		HEX HEAD BOLT M10 X 50L PARTIAL THREAD
118	2		PLASTIC PAD 30 X 42
119	8		SELF-DRIVEN CROSSHEAD SCREW M4 X 10L FULL THREAD
121	1		CHROME PLATE
122	1		ALLEN HEAD BOLT M10 X 60L PARTIAL THREAD

Cable List

KEY#	QTY	PART#	DESCRIPTION
105	1		FUNCTIONAL TRAINING ARM CABLE 3028mm
106	1		LAT PULLDOWN CABLE 5425mm
107	1		LEG EXTENSION CABLE 3540mm
108	1		LEFT ATTACHMENT CABLE 1765mm
109	1		SHORT CABLE 775mm
110	2		TURNPLATE CABLE 523mm
120	1		RIGHT ATTACHMENT CABLE 3435mm

Accessories List

KEY#	QTY	PART#	DESCRIPTION
111	2		ARTICULATING FUNCTIONAL TRAINING HARNESS
112	2		FOAM GRIP 1 1/2" OD X 8 1/2"L (low row bar)
113	2		FOAM GRIP Φ 34 OD X 540L (lat bar)
114	1		LAT BAR
115	1		LAT BAR PAD
116	1		LOW ROW BAR
117	1		LEG HARNESS

Part numbers are required when ordering parts.

F500 HARDWARE

(shown in actual size)

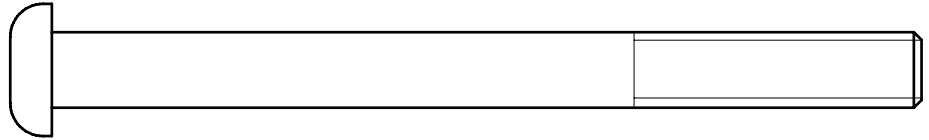
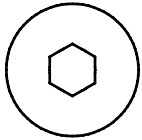

KEY # 02 ALLEN HEAD BOLT M10X115L PARTIAL THRERD QTY.3

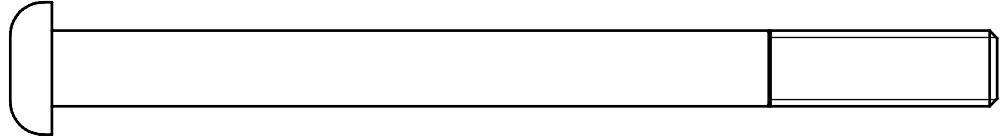
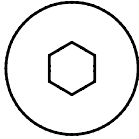

KEY # 03 ALLEN HEAD BOLT M10X125L PARTIAL THRERD QTY.4

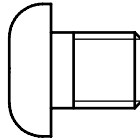
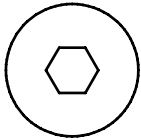

KEY # 04 ALLEN HEAD BOLT M10X12L FULL THRERD QTY.4

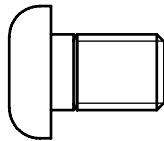
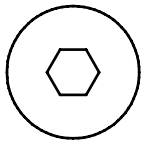

KEY # 05 ALLEN HEAD BOLT M10X15L FULL THRERD QTY.7

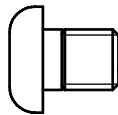
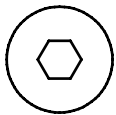

KEY # 10 ALLEN HEAD BOLT M8X10L FULL THRERD QTY.5

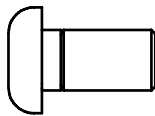
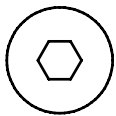

KEY # 11 ALLEN HEAD BOLT M8X15L FULL THRERD QTY.2

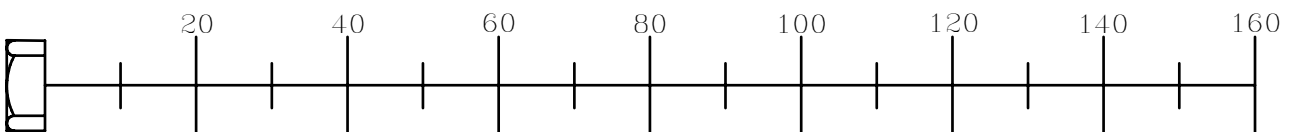

F500 HARDWARE

(shown in actual size)

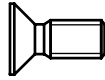

KEY # 25 TAPERED CROSSHEAD SCREW M5X10L FULL THREAD QTY.2



KEY # 31 CROSSHEAD SCREW M4X6L FULL THREAD QTY.3

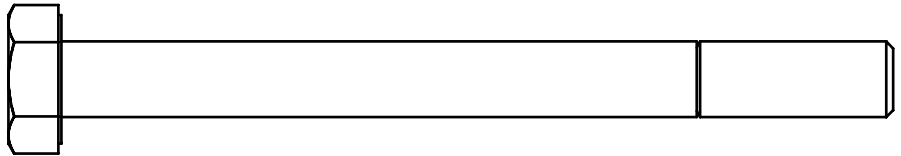
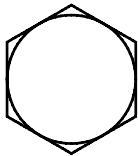

KEY # 44 HEX HEAD BOLT M10X110L PARTIAL THREAD QTY.1

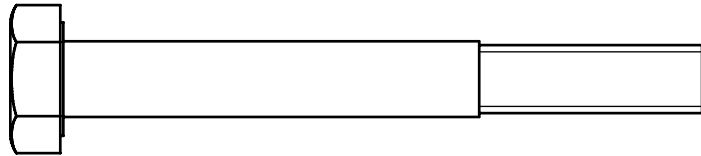
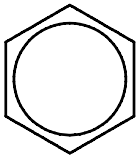

KEY # 45 HEX HEAD BOLT M10X85L PARTIAL THREAD QTY.2

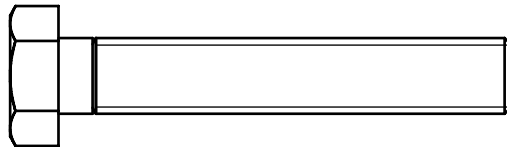
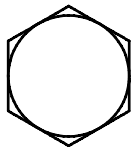

KEY # 46 ALLEN HEAD BOLT M10X60L PARTIAL THRERD QTY.1

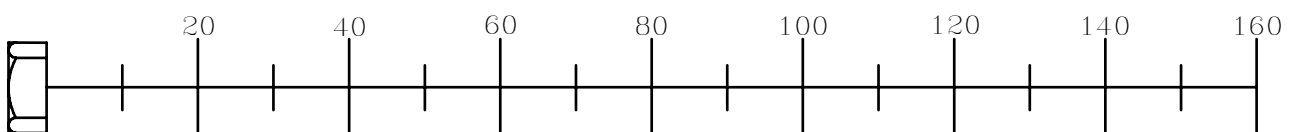

F500 HARDWARE

(shown in actual size)

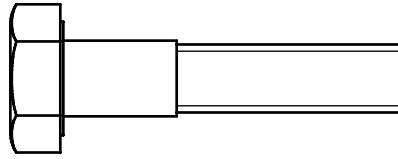
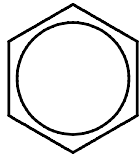

KEY # 47 HEX HEAD BOLT M10X45L PARTIAL THREAD QTY.16

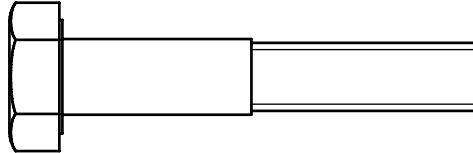
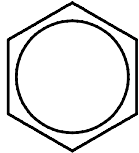

KEY # 48 HEX HEAD BOLT M10X55L PARTIAL THREAD QTY.2

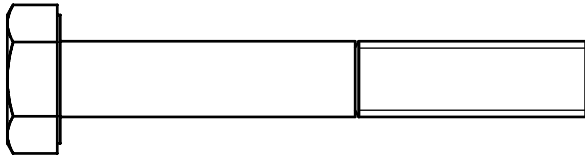
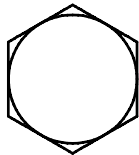

KEY # 49 HEX HEAD BOLT M10X70L PARTIAL THREAD QTY.1

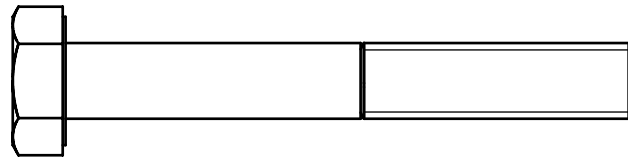
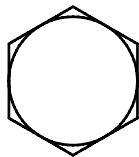

KEY # 50 HEX HEAD BOLT M10X75L PARTIAL THREAD QTY.12

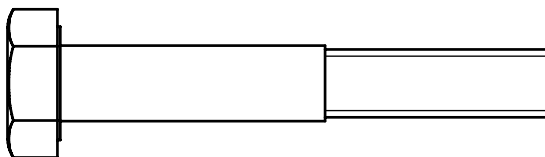
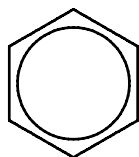

KEY # 51 HEX HEAD BOLT M10X65L PARTIAL THREAD QTY.1

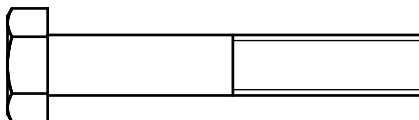
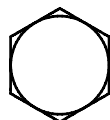

KEY # 52 HEX HEAD BOLT M8X50L PARTIAL THREAD QTY.2

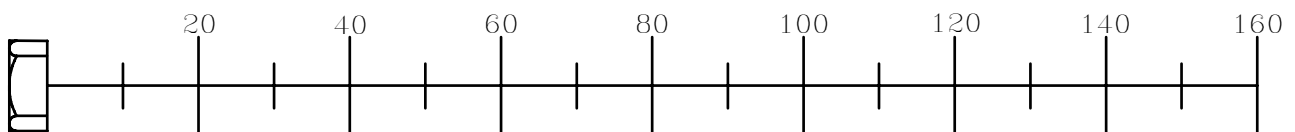

F500 HARDWARE

(shown in actual size)

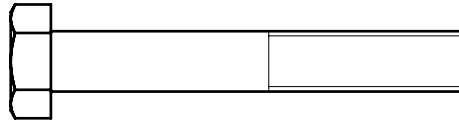
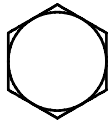

KEY # 53 HEX HEAD BOLT M8X55L PARTIAL THREAD QTY.2

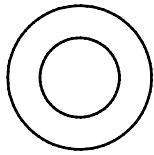

KEY # 100 WASHER M10 X Ø19 QTY.4

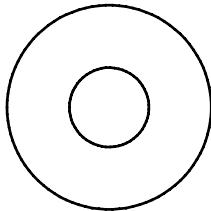

KEY # 101 WASHER M10 X Ø27 QTY.84

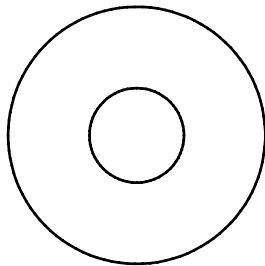

KEY # 102 WASHER M12XØ34 QTY.2

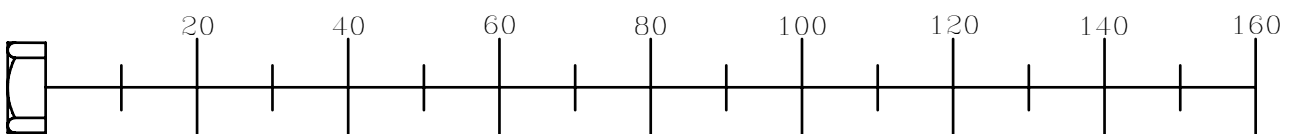

EXPLODED VIEW DIAGRAM F500

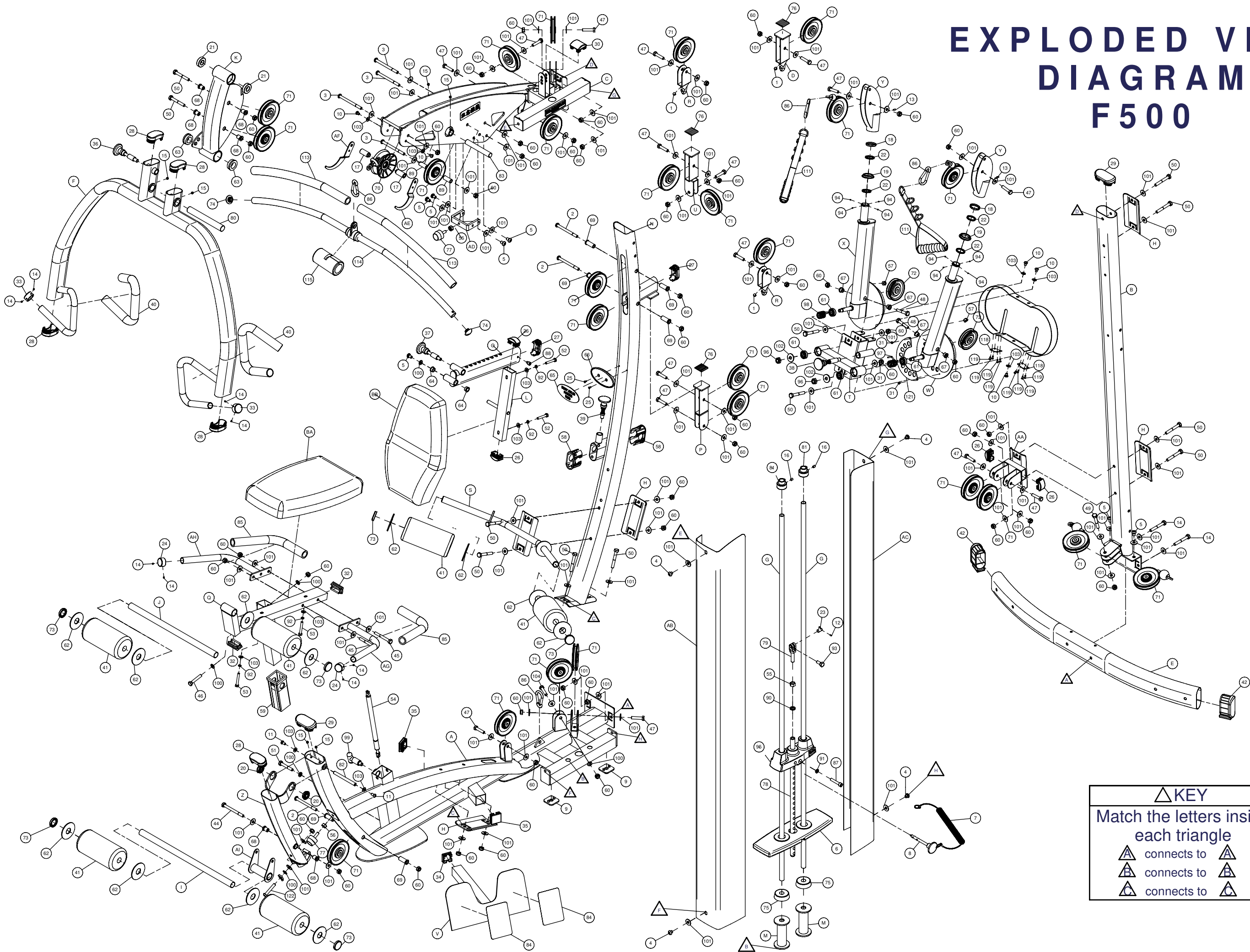

△ KEY
Match the letters inside each triangle

△ connects to	△
△ connects to	△
△ connects to	△