

Инструкция

Мультистанция Body-Solid DGYM

Полезные ссылки:

[Мультистанция Body-Solid DGYM - смотреть на сайте](#)

[Мультистанция Body-Solid DGYM - читать отзывы](#)

Body-Solid

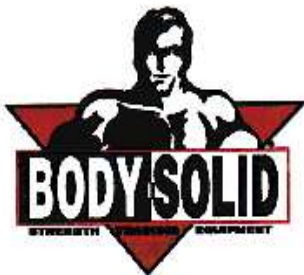
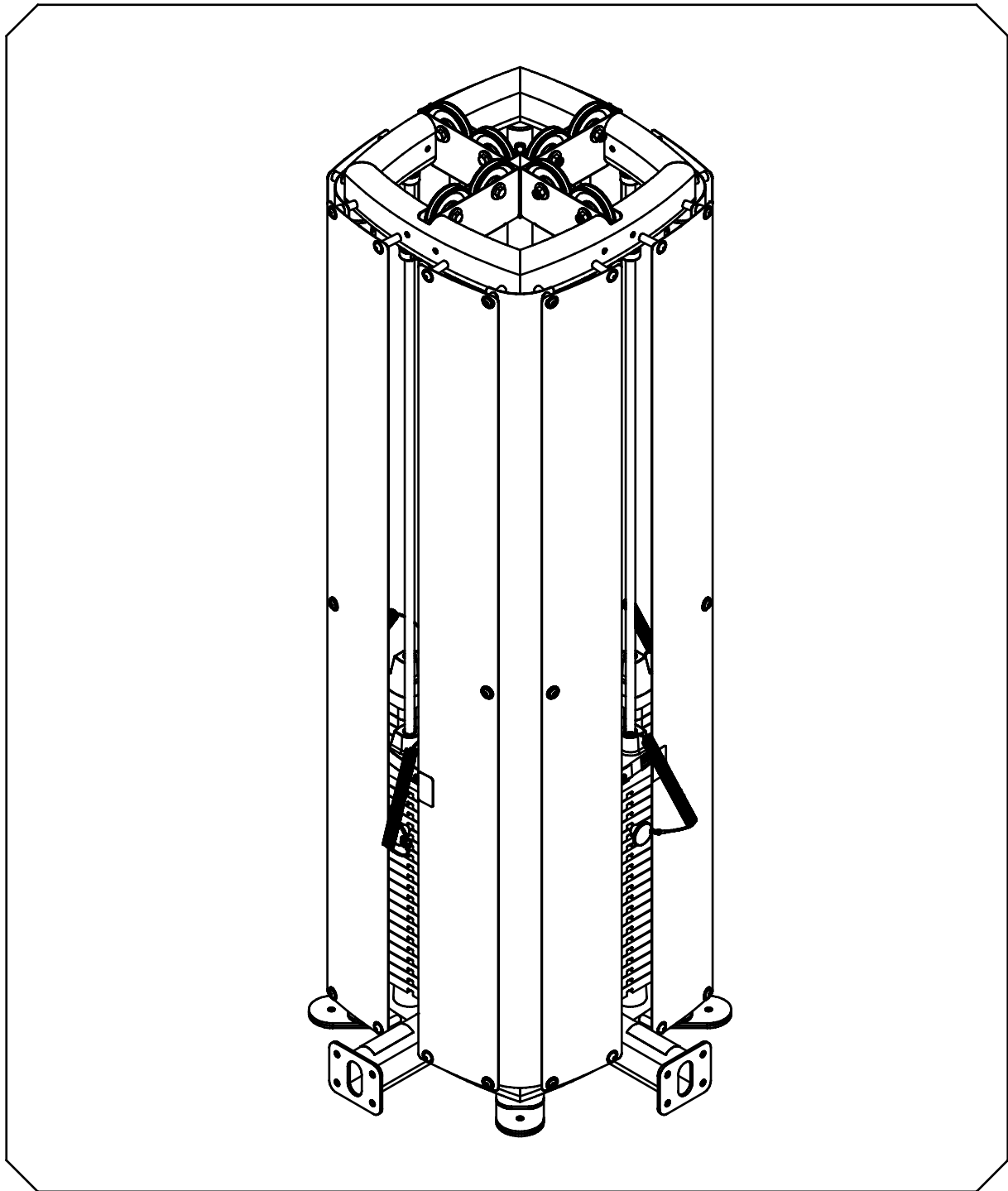

BODY-SOLID, Inc.
1900 S. Des Plaines Ave.
Forest Park, IL 60130 USA
Phone: (708) 427-3555
Fax: (708) 427-3556
www.bodysolid.com

DGYM OWNER'S MANUAL

DGYM ASSEMBLY INSTRUCTIONS

HARDWARE ILLUSTRATION

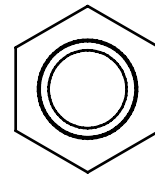
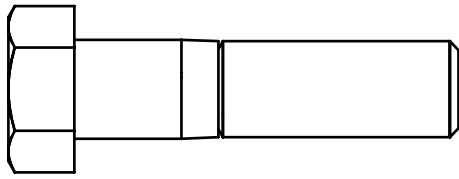

(A1) HEX BOLT 1/2"x2"L PARTIAL THREAD QTY.8

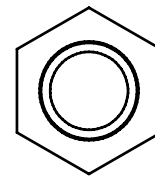
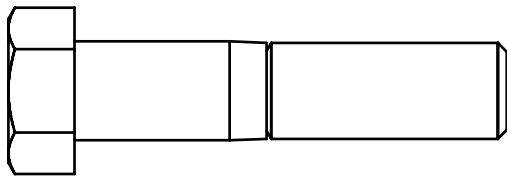

(A2) HEX BOLT 1/2"x2 1/4"L PARTIAL THREAD QTY.8

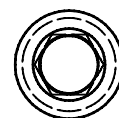
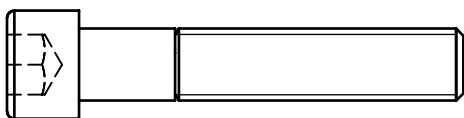

(A3) ROUND ALLEN HEAD 3/8"x2"L PARTIAL THREAD QTY.4

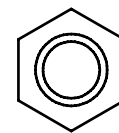
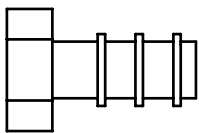

(A4) HEX BOLT 3/8"x3/4"L PARTIAL THREAD QTY.16

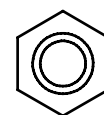
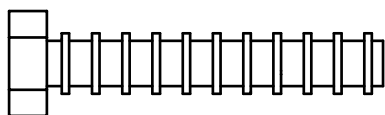

(A5) HEX BOLT 5/16"x1 3/4"L PARTIAL THREAD QTY.4

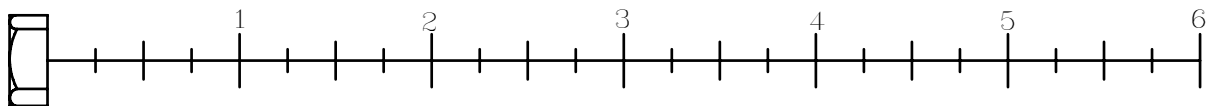

DGYM ASSEMBLY INSTRUCTIONS

HARDWARE ILLUSTRATION

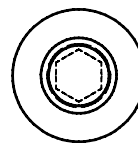
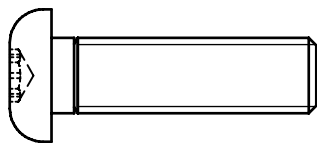

(A6)ROUND ALLEN HEAD M10X35L PARTIAL THREAD QTY.8

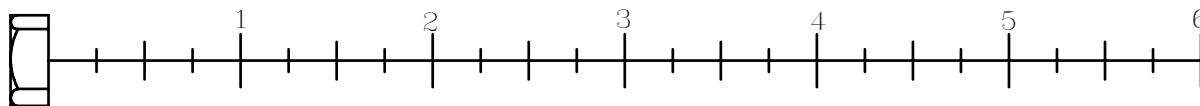

DGYM ASSEMBLY INSTRUCTIONS

HARDWARE ILLUSTRATION



(A7) ALLEN SCREW 5/16"X3/8"L PARTIAL THREAD QTY.12

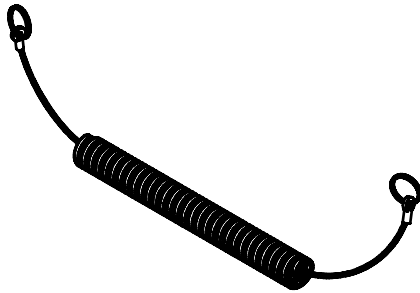

(A8) ELASTIC BOLT QTY.4

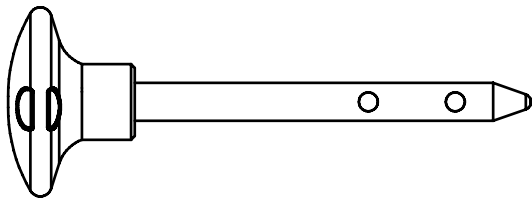

(A9) 10LB PIN (8250-071) QTY.4

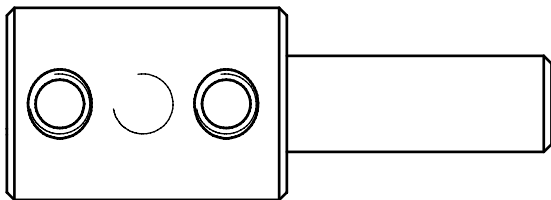

(A10) WEIGHT STACK CABLE (8260-009) QTY.4

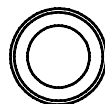
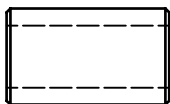

(A11) IMMOBILE COVER Ø1/2"XØ8.5X21.5L(8690-012) QTY.4

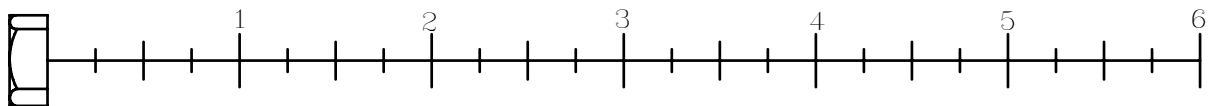

DGYM ASSEMBLY INSTRUCTIONS

HARDWARE ILLUSTRATION

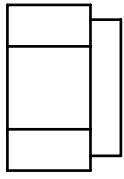

(B1) NYLON LOCK NUT 1/2" QTY.16

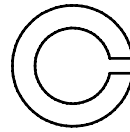
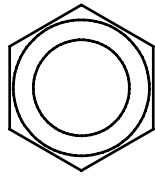

(C3) 3/8"(I.D.) SPRING WASHER QTY.4

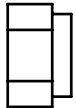
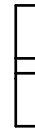

(B2) NYLON LOCK NUT 5/16" QTY.4

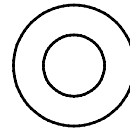

(C4) 5/16"(I.D.) FLAT WASHER Ø16 QTY.8



(B3) NYLON LOCK NUT 1/2"X13UNCX8T QTY.4

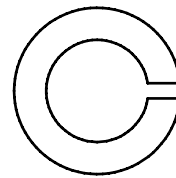
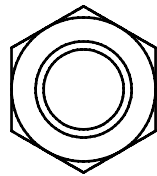

(C5) 1/2"(I.D.) SPRING WASHER QTY.4

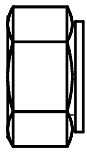
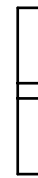

(B4) NYLON LOCK NUT M10 QTY.8

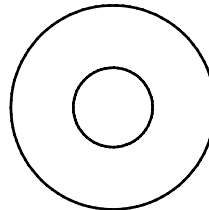
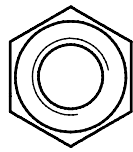

(C6) M10(I.D.) FLAT WASHER Ø27 QTY.16

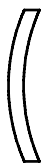

(C2) M10(I.D.) FLAT CURVED WASHER R30 Ø20 QTY.16

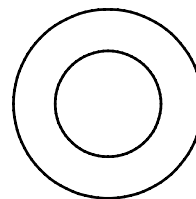
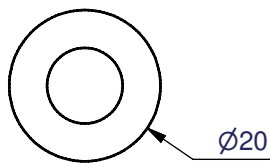

(C7) 1/2"(I.D.) FLAT WASHER Ø25 QTY.32

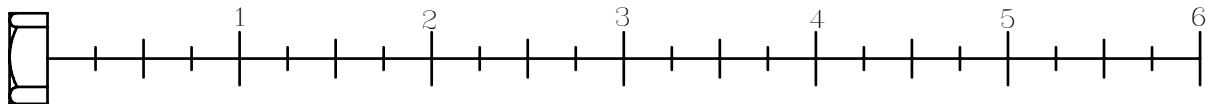
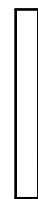

DGYM ASSEMBLY INSTRUCTIONS

HARDWARE ILLUSTRATION

D1.Ø3/4"X8L STEEL BUSHING (8110-014)	[8PCS]
D2.Ø3/4"X19.5L STEEL BUSHING (8110-017)	[24PCS]
D3.Ø3/4" SHAFT COLLAR(9211-046)	[8PCS]
D4.Ø65XØ20X70L RUBBER DOUNT(9310-049)	[8PCS]
D5.95X250 RUBBER PAD(9310-060)	[4PCS]
D6.WEIGHT SELECTOR BAR(8210-042)	[4PCS]
D7.Ø117 PULLEY(9213-010B)	[16PCS]
D8.TOP PLATE(8400-006)	[4PCS]
D9.2085mm STEEL CABLE(FDGYMA)	[4PCS]

D1



D2



D3



D4

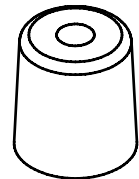

D5

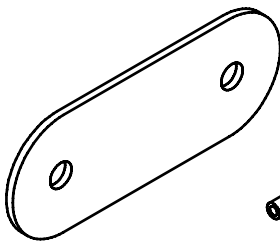

D6

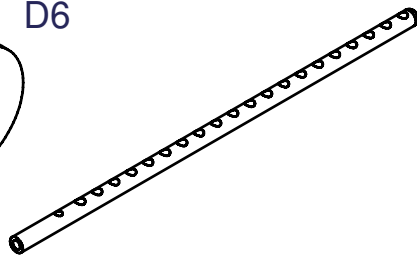

D7

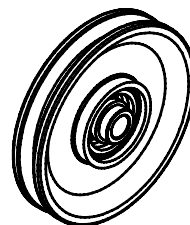

D8

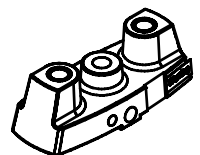

D9

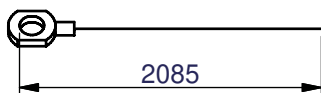

DGYM ASSEMBLY INSTRUCTIONS

HARDWARE ILLUSTRATION

D11.4770mm DABB For DGYM Steel Cable(FDIOTC)-----	[1PCS]
D12.4950mm DBTC For DGYM Steel Cable(FDBTCB)-----	[1PCS]
D13.4350mm DCLP For DGYM Steel Cable(FDCLPC)-----	[1PCS]
D14.3170mm DIOT For DGYM Steel Cable(FDIOTC)-----	[1PCS]
D15.7605mm DLAT For DGYM Steel Cable(FDLATC)-----	[1PCS]
D16.5000mm DLEC For DGYM Steel Cable(FDLECB)-----	[1PCS]
D17.4555mm DPCC For DGYM Steel Cable(FDPCCC)-----	[1PCS]
D18.4665mm DPEC For DGYM Steel Cable(FDPECC)-----	[1PCS]
D19.8645mm DPLS For DGYM Steel Cable(FDPLSB)-----	[1PCS]
D20.3805mm DPRS For DGYM Steel Cable(FDPRSC)-----	[1PCS]

D11

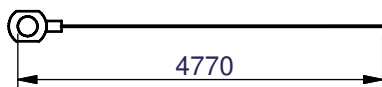

D16

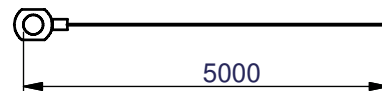

D12

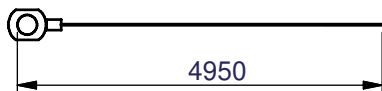

D17

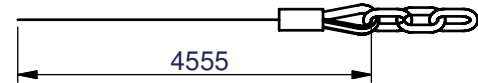

D13

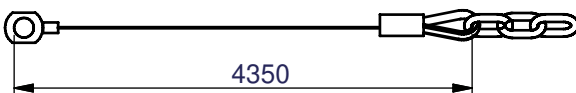

D18

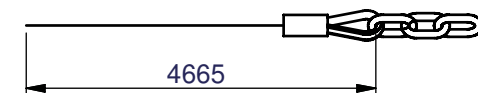

D14

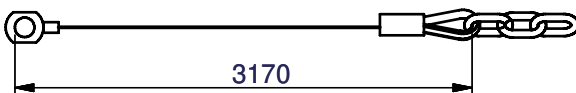

D19

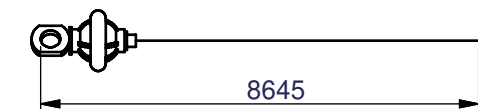

D15

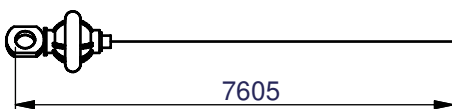

D20



DGYM ASSEMBLY INSTRUCTIONS

PARTS ILLUSTRATION SHEET

A[1PCS]
6610-004

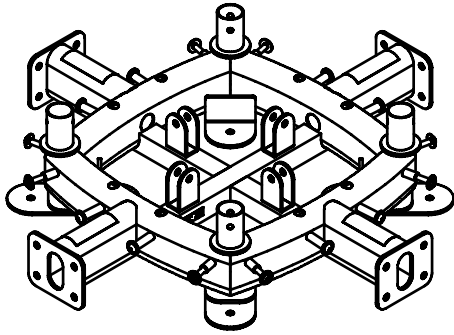

B[1PCS]
6610-005

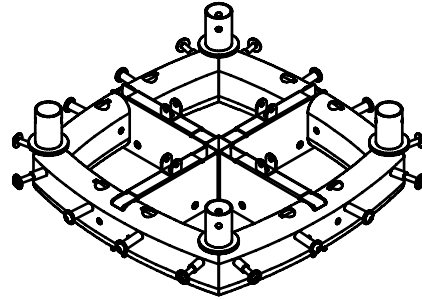

C[4PCS]
6610-006



D[4PCS]
6640-001

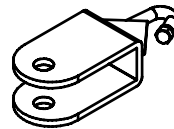

E[4PCS]
8380-053

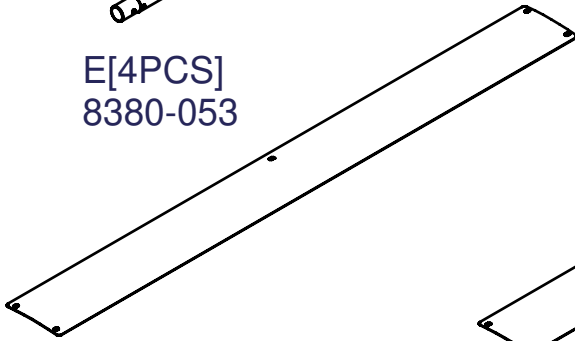

F[4PCS]
8380-053

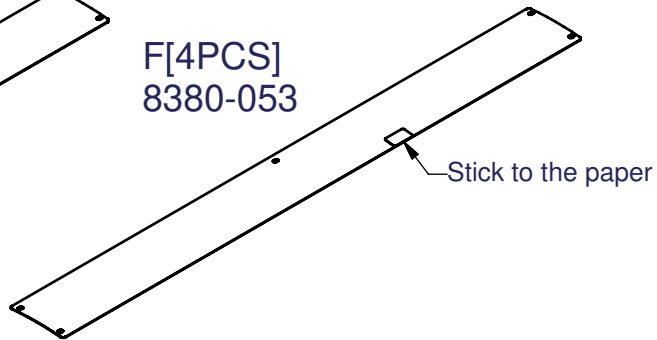

G[4PCS]
8380-054

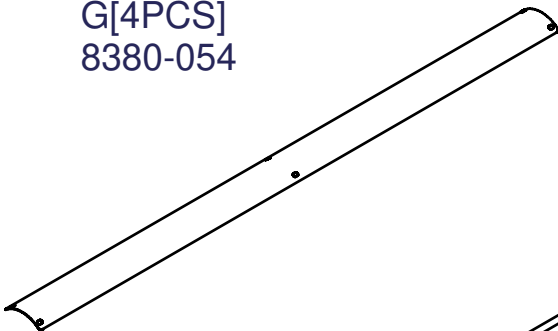

H[8PCS]
5313-Y002

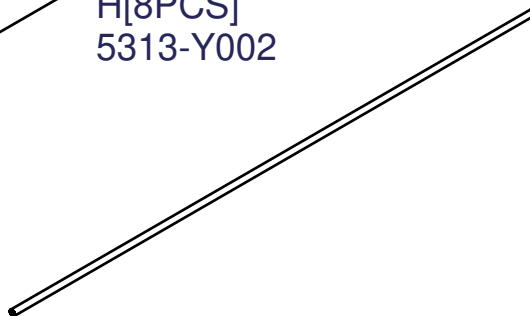

DGYM ASSEMBLY INSTRUCTIONS

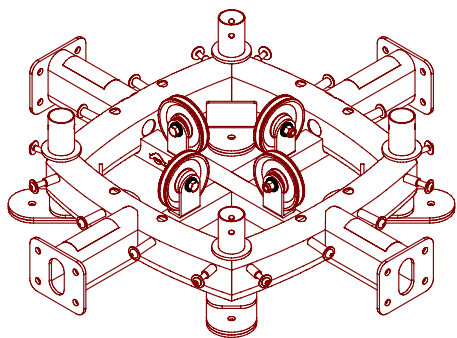

Above shows STEP 1
assembled and completed

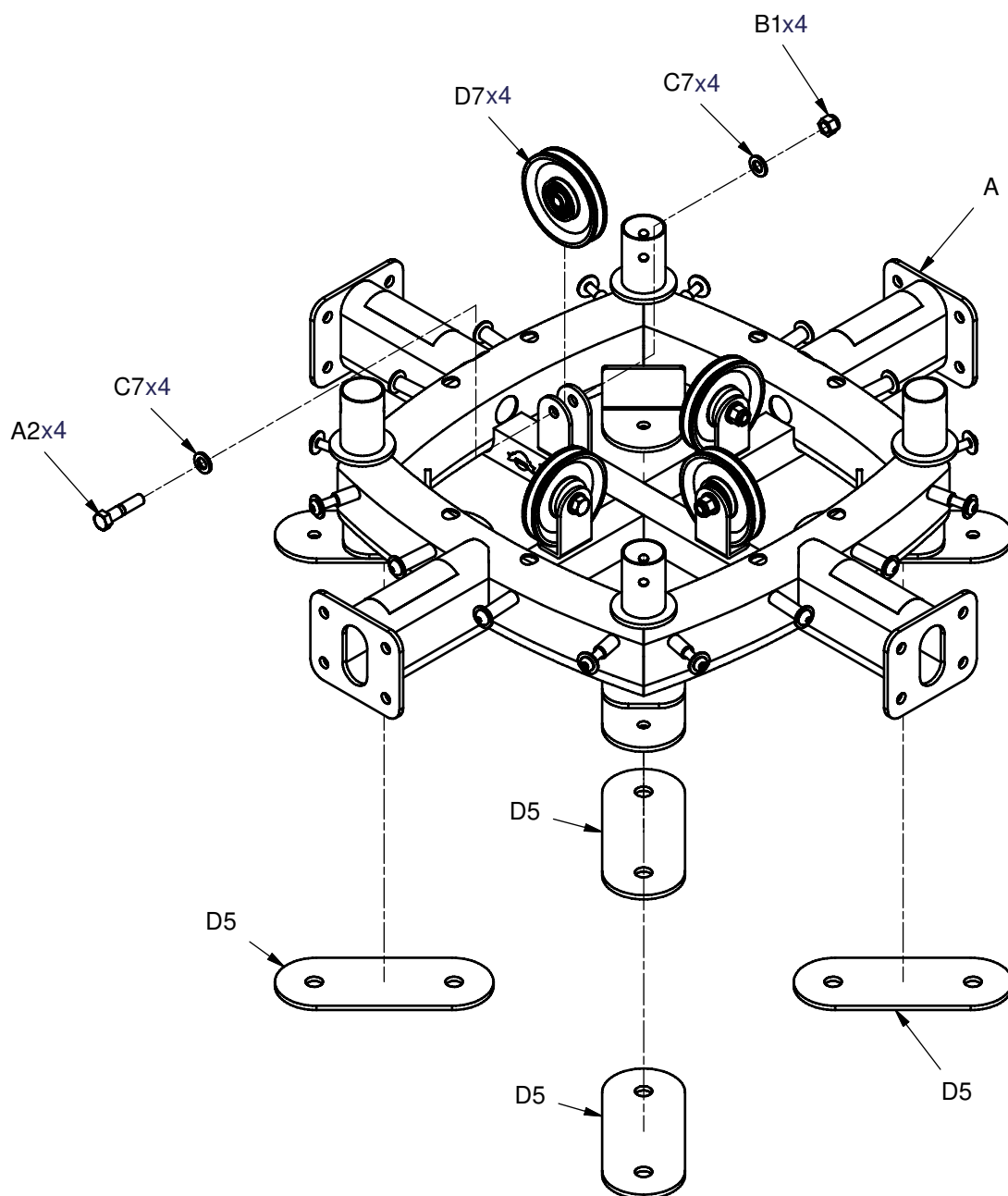

DGYM ASSEMBLY INSTRUCTIONS

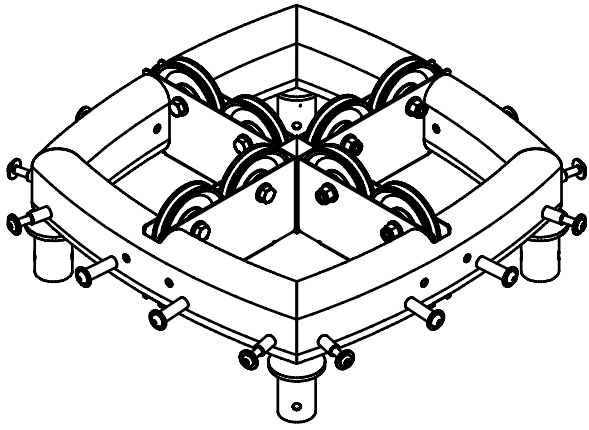

Above shows STEP 2
assembled and completed

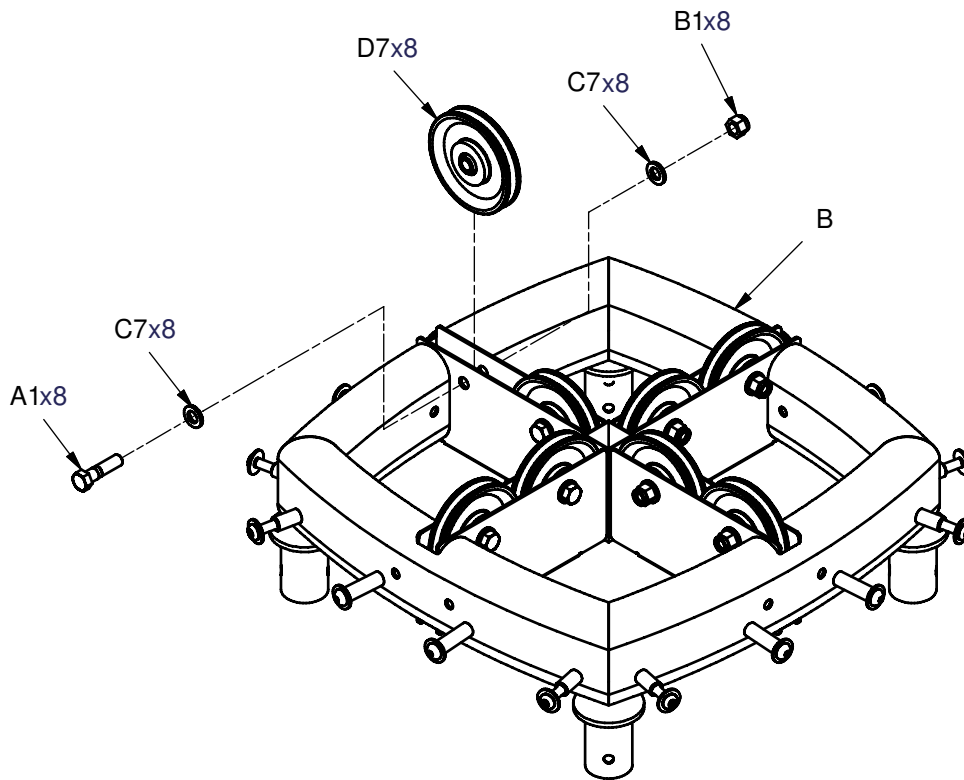

DGYM ASSEMBLY INSTRUCTIONS

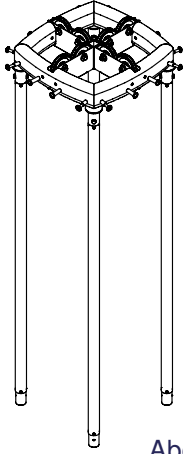

Above shows STEP 3
assembled and completed

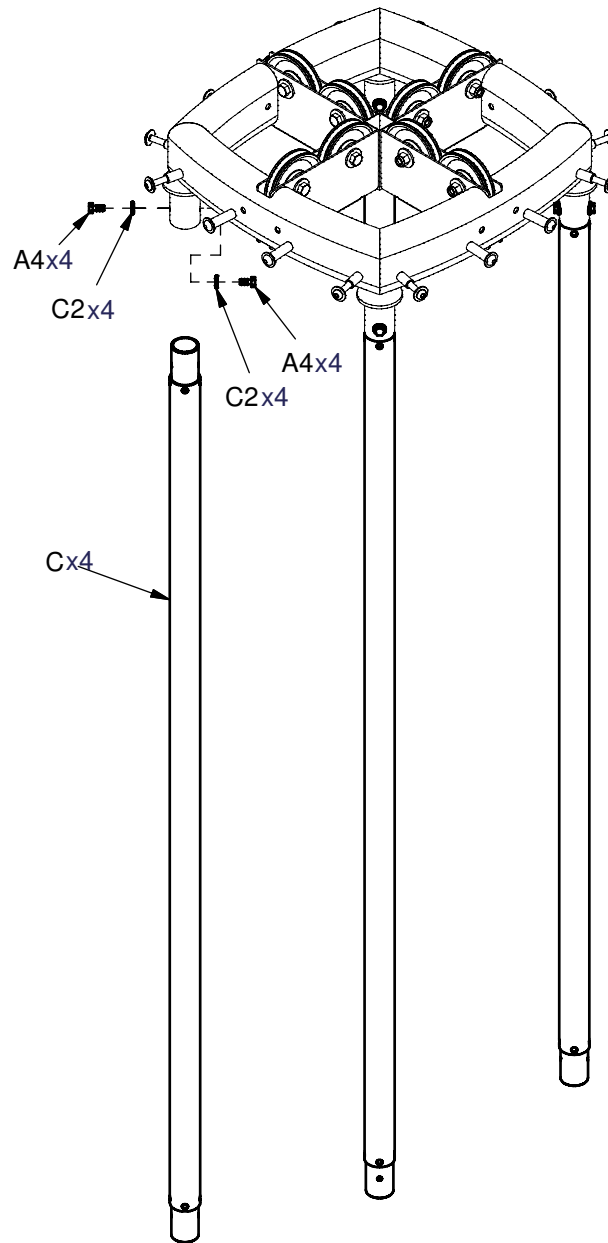

DGYM ASSEMBLY INSTRUCTIONS

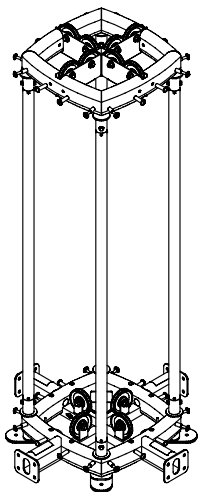

Above shows STEP 4
assembled and completed

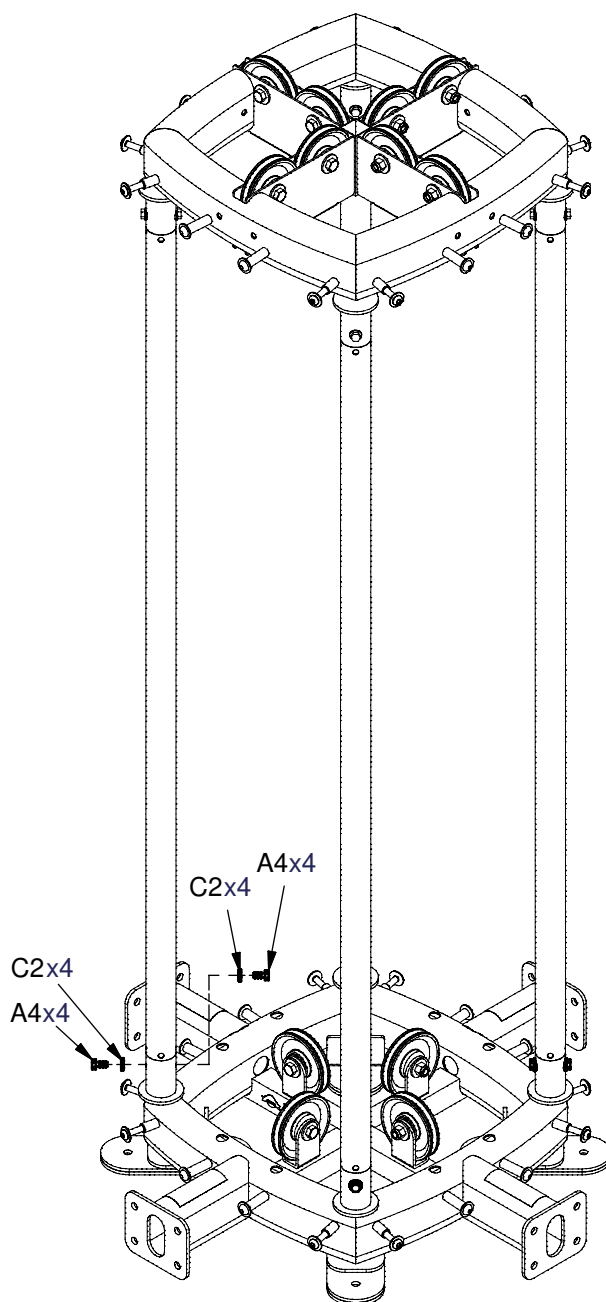

DGYM ASSEMBLY INSTRUCTIONS

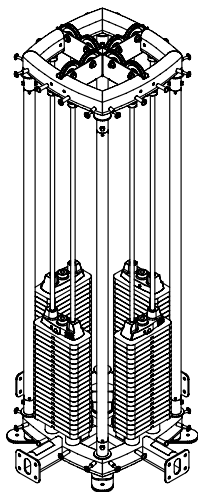

Above shows STEP 5 assembled and completed

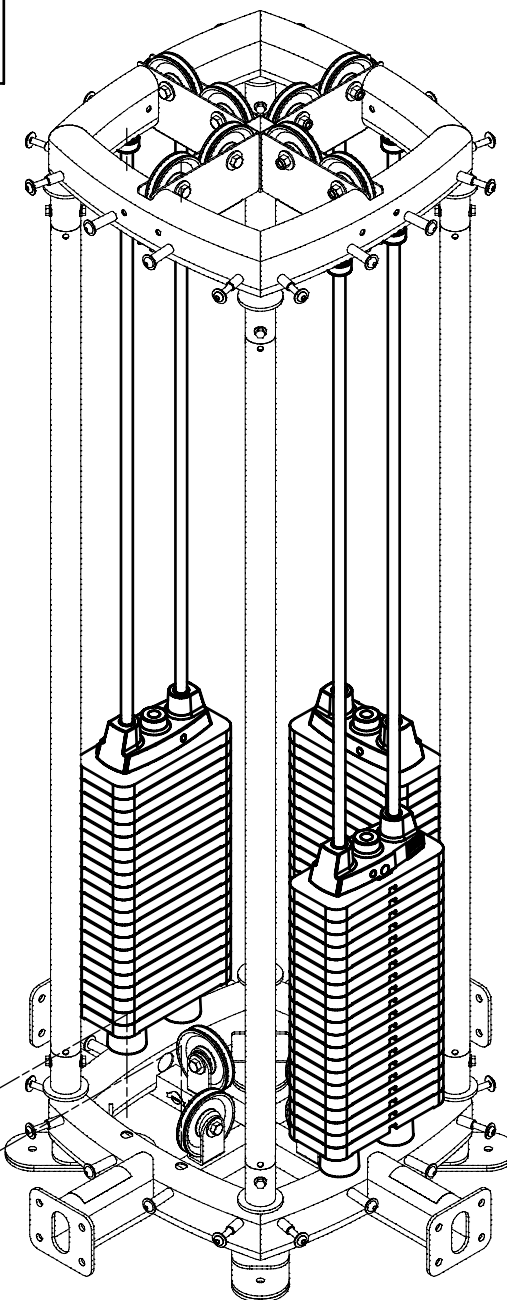
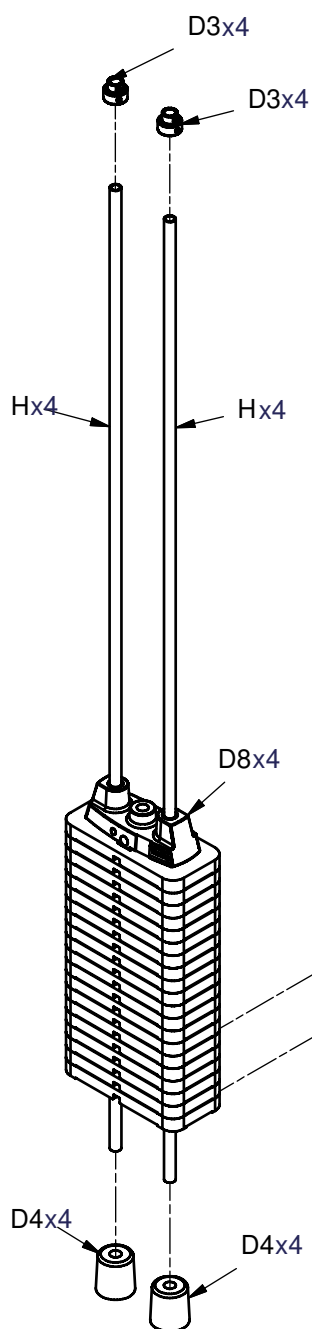

DGYM ASSEMBLY INSTRUCTIONS

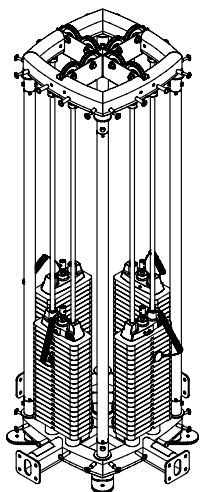

Above shows STEP 6
assembled and completed

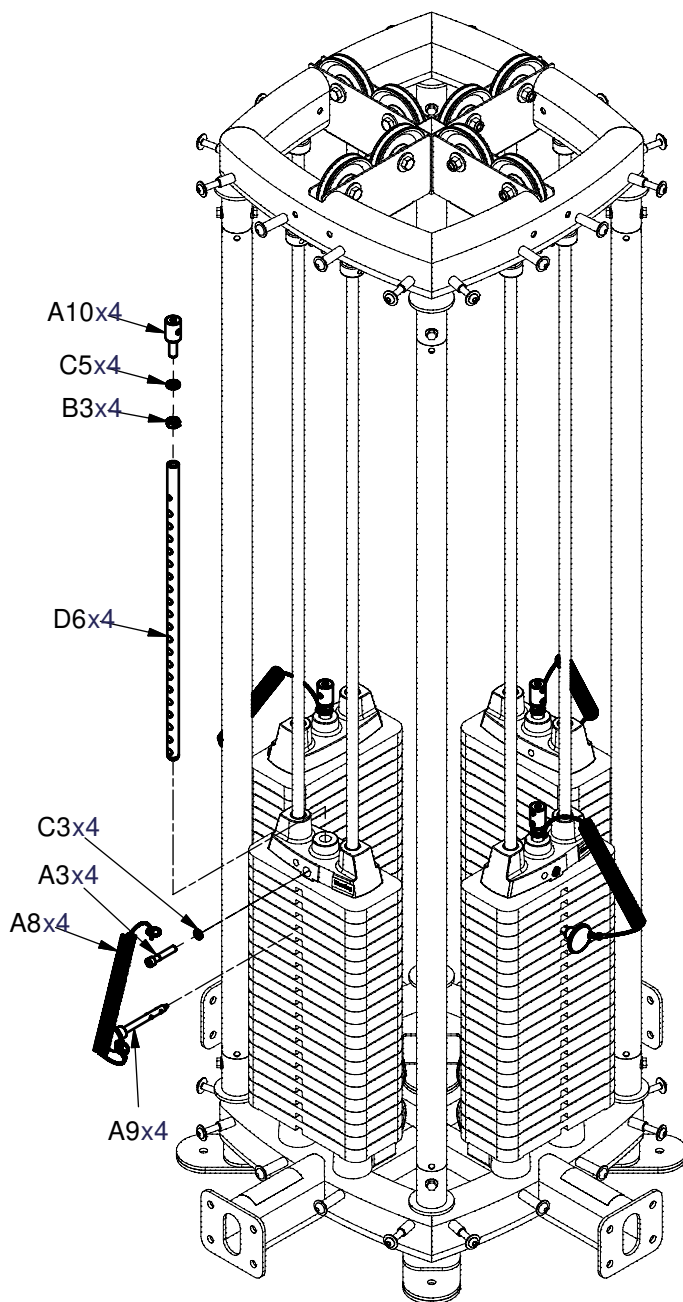

DGYM ASSEMBLY INSTRUCTIONS

Cable to match illustration

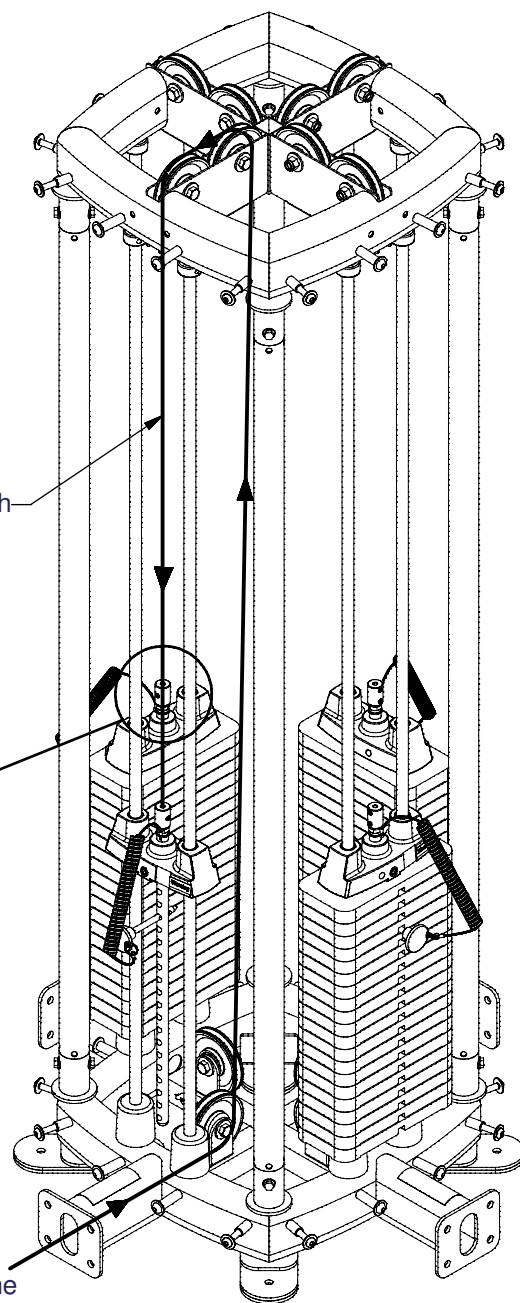

Single time of strength

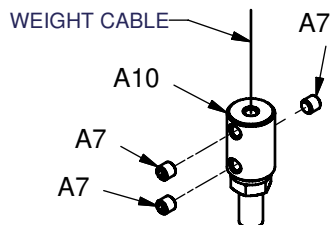

DETAIL VIEW

Constitute Dual Machine
DPEC, DBTC, DLEC,
DABB, DLAT, DPLS,
DPCC

DGYM ASSEMBLY INSTRUCTIONS

Cable to match illustration

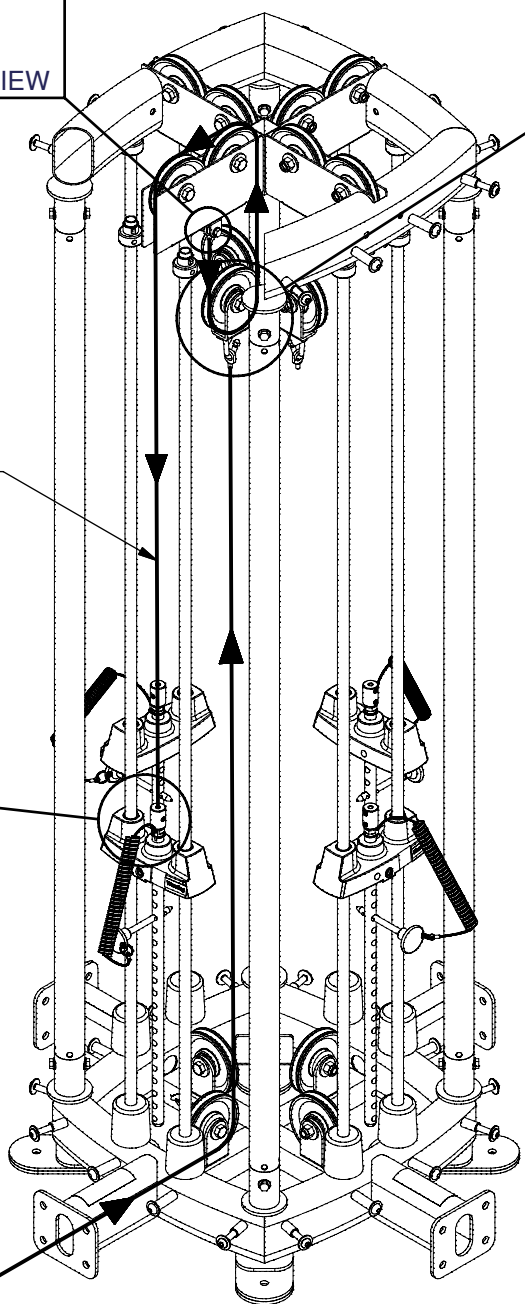
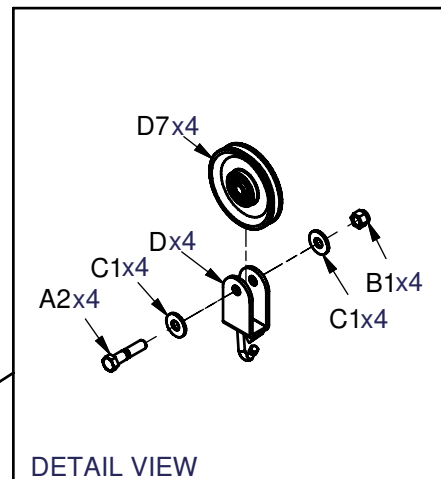
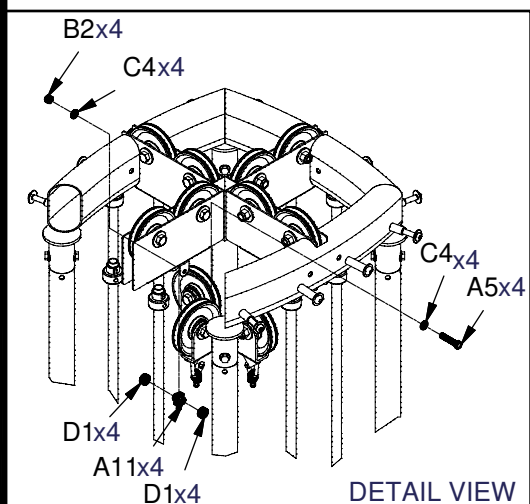

Double strength(D9)

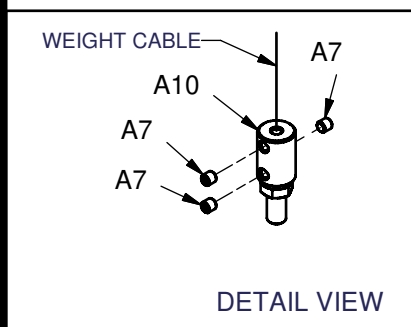

Constitute Dual Machine
DCLP, DIOT, DPRS

DGYM ASSEMBLY INSTRUCTIONS

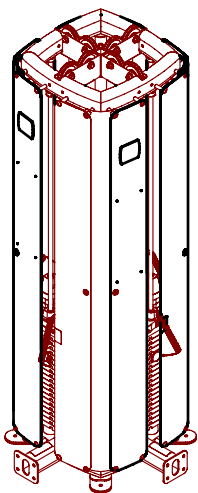

Above shows STEP 7 assembled and completed

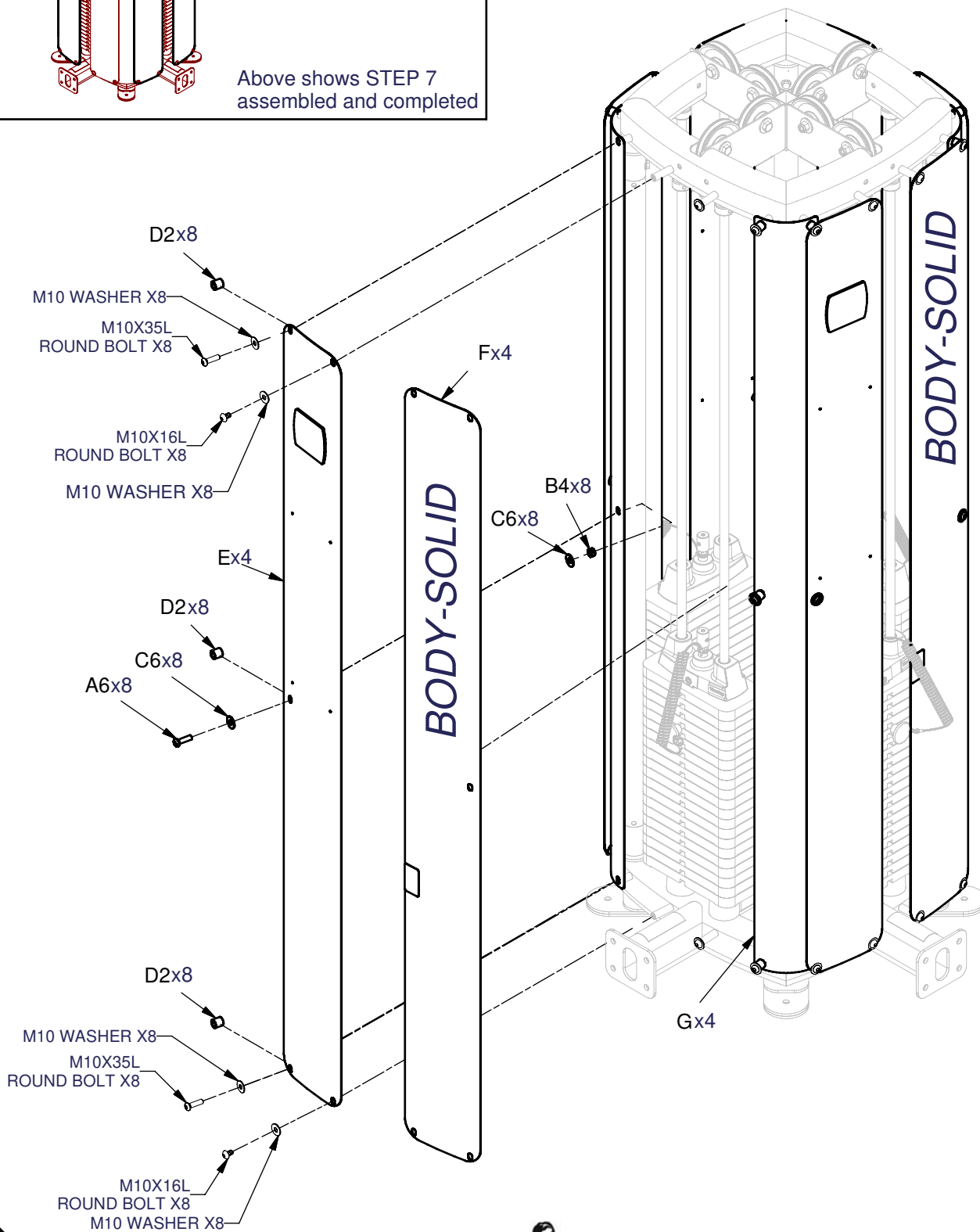

DGYM ASSEMBLY INSTRUCTIONS

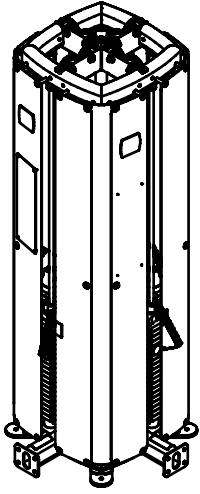

Above shows STEP 8
assembled and completed

