

Инструкция

Мультистанция Weider 6900

Полезные ссылки:

[Мультистанция Weider 6900 - смотреть на сайте](#)

[Мультистанция Weider 6900 - читать отзывы](#)

WEIDERPRO™ 6900

Model No. 29838.0

Serial No. _____

Write the serial number in the space above for reference.

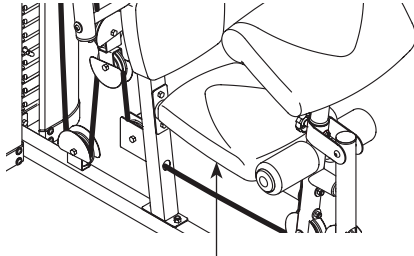

Serial Number Decal
(under the seat)

ACTIVATE YOUR WARRANTY

To register your product and activate your warranty today, contact Customer Service.

CUSTOMER SERVICE

Call toll-free 1-888-936-4266
Mon.–Fri. 7:30 a.m.–4:30 p.m. ET
(excluding holidays)

or email us at
customerservice@iconcanada.ca

Please do not contact the store.

⚠ CAUTION

Read all precautions and instructions in this manual before using this equipment. Keep this manual for future reference.

USER'S MANUAL

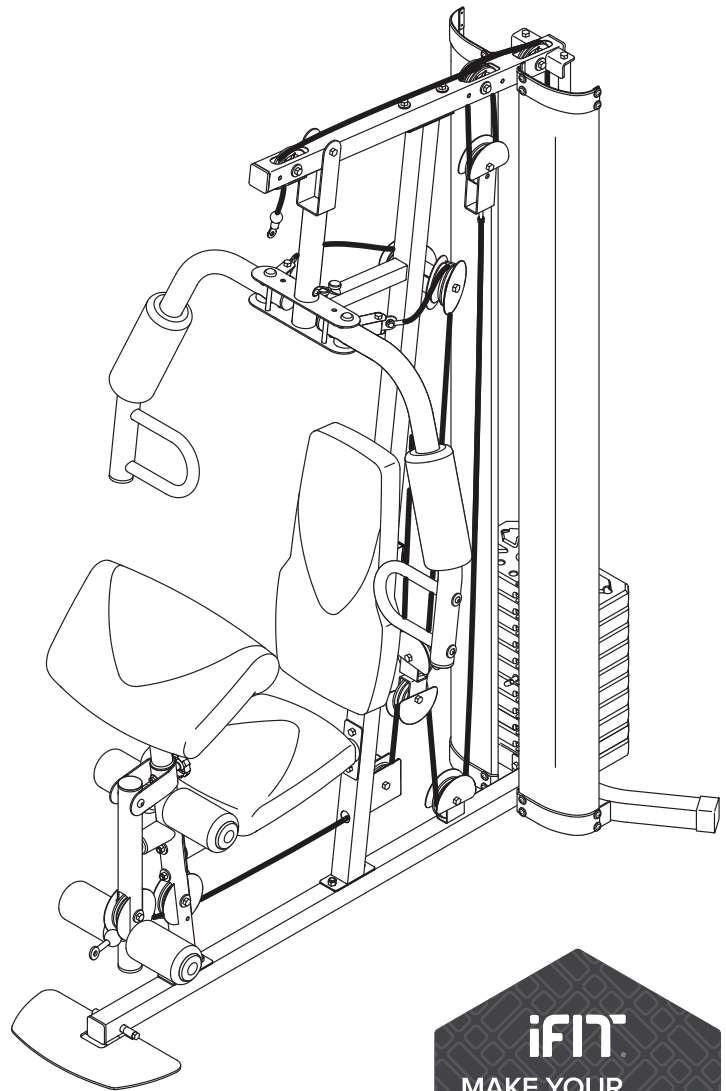

TABLE OF CONTENTS

WARNING DECAL PLACEMENT	2
IMPORTANT PRECAUTIONS	3
BEFORE YOU BEGIN	5
PART IDENTIFICATION CHART	6
ASSEMBLY	7
ADJUSTMENT	22
WEIGHT RESISTANCE CHART	24
MAINTENANCE	25
CABLE DIAGRAM	26
EXERCISE GUIDELINES	27
PART LIST	28
EXPLODED DRAWING	30
ORDERING REPLACEMENT PARTS	Back Cover
LIMITED WARRANTY	Back Cover

WARNING DECAL PLACEMENT

This drawing shows the location(s) of the warning decal(s). **If a decal is missing or illegible, call the telephone number on the front cover of this manual and request a free replacement decal. Apply the decal in the location shown.** Note: The decal(s) may not be shown at actual size.

⚠ WARNING

- Misuse of this machine may result in serious injury.
- Read user's manual prior to use and follow all warnings and instructions.
- Do not allow children on or around machine.
- User weight must not exceed 300 pounds.
- Replace label if damaged, illegible, or removed.



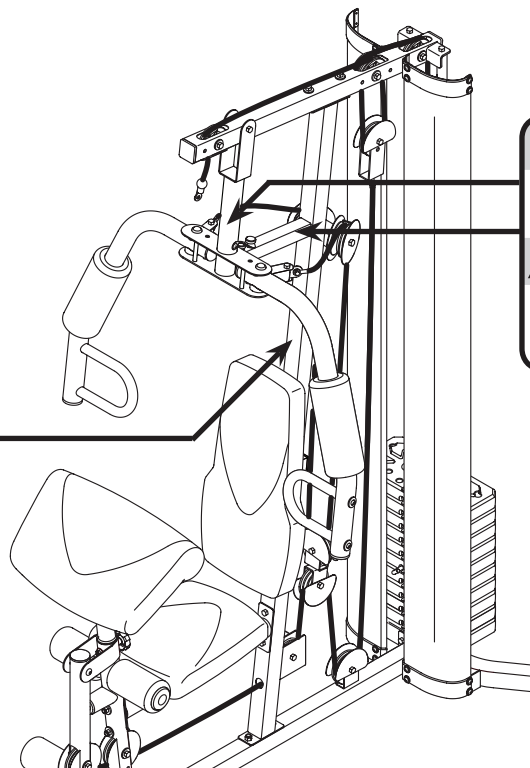

⚠ WARNING

- Keep hands and fingers clear of this area.

⚠ ATTENTION

- Gardez vos mains et vos doigts éloignés de cet endroit.

Part # 166295

IMPORTANT PRECAUTIONS

⚠️ WARNING: To reduce the risk of serious injury, read all important precautions and instructions in this manual and all warnings on your weight system before using your weight system. ICON assumes no responsibility for personal injury or property damage sustained by or through the use of this product.

1. It is the responsibility of the owner to ensure that all users of the weight system are adequately informed of all precautions.
2. Before beginning any exercise program, consult your physician. This is especially important for persons over age 35 or persons with pre-existing health problems.
3. Use the weight system only as described in this manual.
4. The weight system is intended for home use only. Do not use the weight system in a commercial, rental, or institutional setting.
5. Use the weight system only on a level surface. Cover the floor beneath the weight system to protect the floor.
6. Inspect and properly tighten all parts regularly. Replace any worn parts immediately.
7. Keep children under age 12 and pets away from the weight system at all times.
8. The weight system should not be used by persons weighing more than 300 lbs. (136 kg).
9. Wear appropriate exercise clothes while exercising; do not wear loose clothes that could become caught on the weight system. Always wear athletic shoes for foot protection.
10. Keep hands and feet away from moving parts.
11. Always secure the weight stack with the lock pin and the lock after exercising to prevent unauthorized use of the weight system (see LOCKING THE WEIGHT STACK on page 24).
12. Make sure that the cables remain on the pulleys at all times. If the cables bind while you are exercising, stop immediately and make sure that the cables are on the pulleys.
13. Always stand on the foot plate when performing an exercise that could cause the weight system to tip.
14. Never release the arms, leg lever, lat bar, or handle strap while weights are raised. The weights will fall with great force.
15. Always disconnect the lat bar from the weight system when performing an exercise that does not require the lat bar.
16. Over exercising may result in serious injury or death. If you feel faint or if you experience pain while exercising, stop immediately and cool down.

PROTECT

YOUR FITNESS EQUIPMENT
WITH AN EXTENDED SERVICE PLAN



Your new fitness equipment represents a significant investment in your health. Protect your investment now from unexpected mechanical or electrical failures for up to five years.

PLAN FEATURES

- Protection for one to five years
- Over 100 authorized repair centers
- Highly trained repair technicians
- A national toll-free repair hotline
- Simple repair claim procedure
- No claim forms
- Easy enrollment
- Fast, efficient repair anywhere in Canada
- In-home repairs covered
- Parts and labour covered
- Mechanical and electrical failures covered

To protect your fitness equipment today, please
call Customer Care at **1-888-936-4266**
Or, email us at customerservice@iconcanada.ca

du/of Canada Inc.

BEFORE YOU BEGIN

Thank you for selecting the versatile WEIDER PRO™ 6900 weight system. The weight system offers a selection of weight stations designed to develop every major muscle group of the body. Whether your goal is to tone your body, build dramatic muscle size and strength, or improve your cardiovascular system, the weight system will help you to achieve the specific results you want.

For your benefit, read this manual carefully before using the weight system. If you have questions after

reading this manual, please see the front cover of this manual. To help us assist you, note the product model number and serial number before contacting us. The model number and the location of the serial number decal are shown on the front cover of this manual.

Before reading further, please review the drawing below and familiarize yourself with the parts that are labeled.

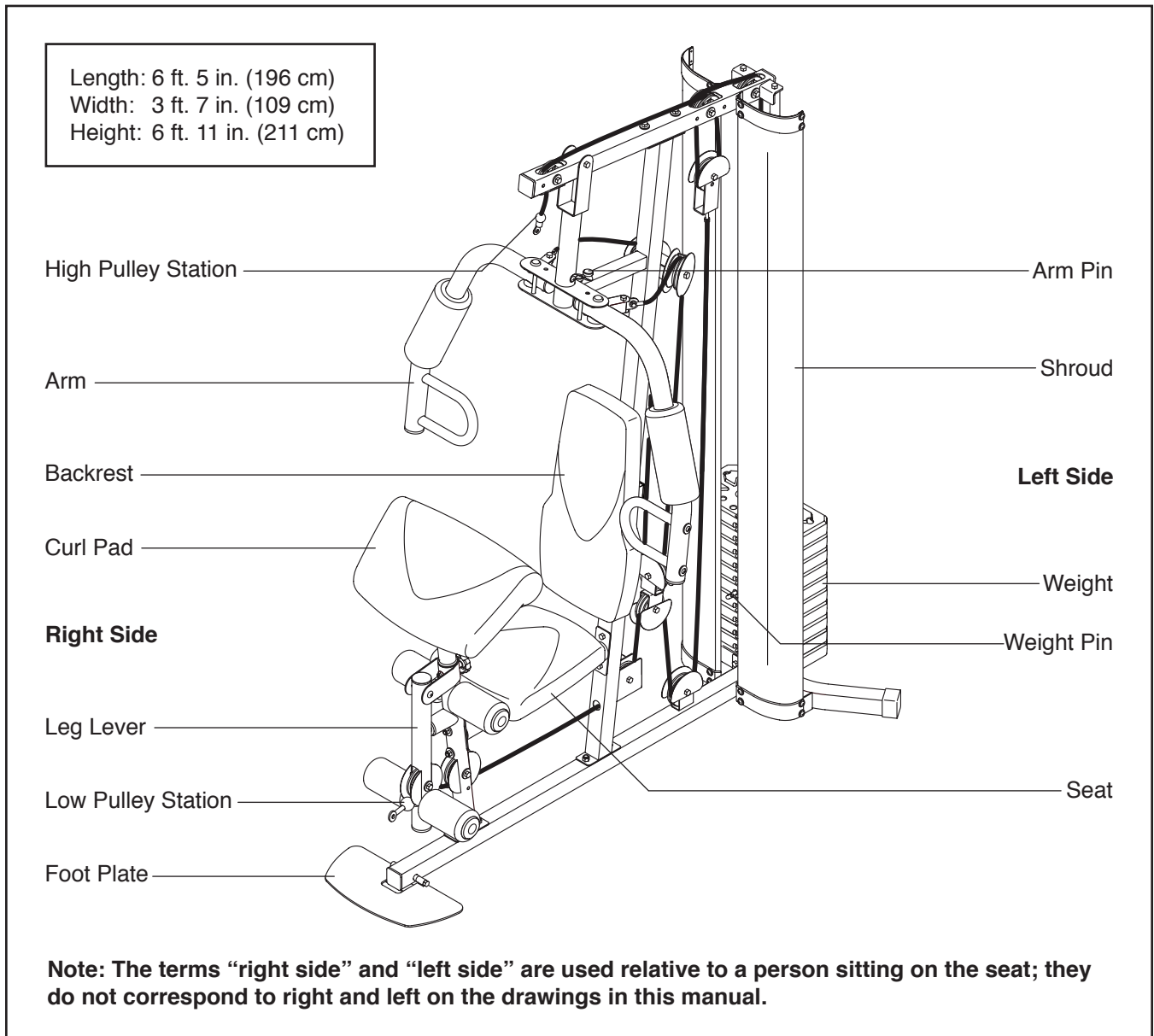

PART IDENTIFICATION CHART

Refer to the drawings below to identify small parts used in assembly. The number in parentheses by each drawing is the key number of the part, from the PART LIST near the end of this manual. **Note: If a part is not in the hardware kit, check to see if it has been preassembled. Extra parts may be included.**

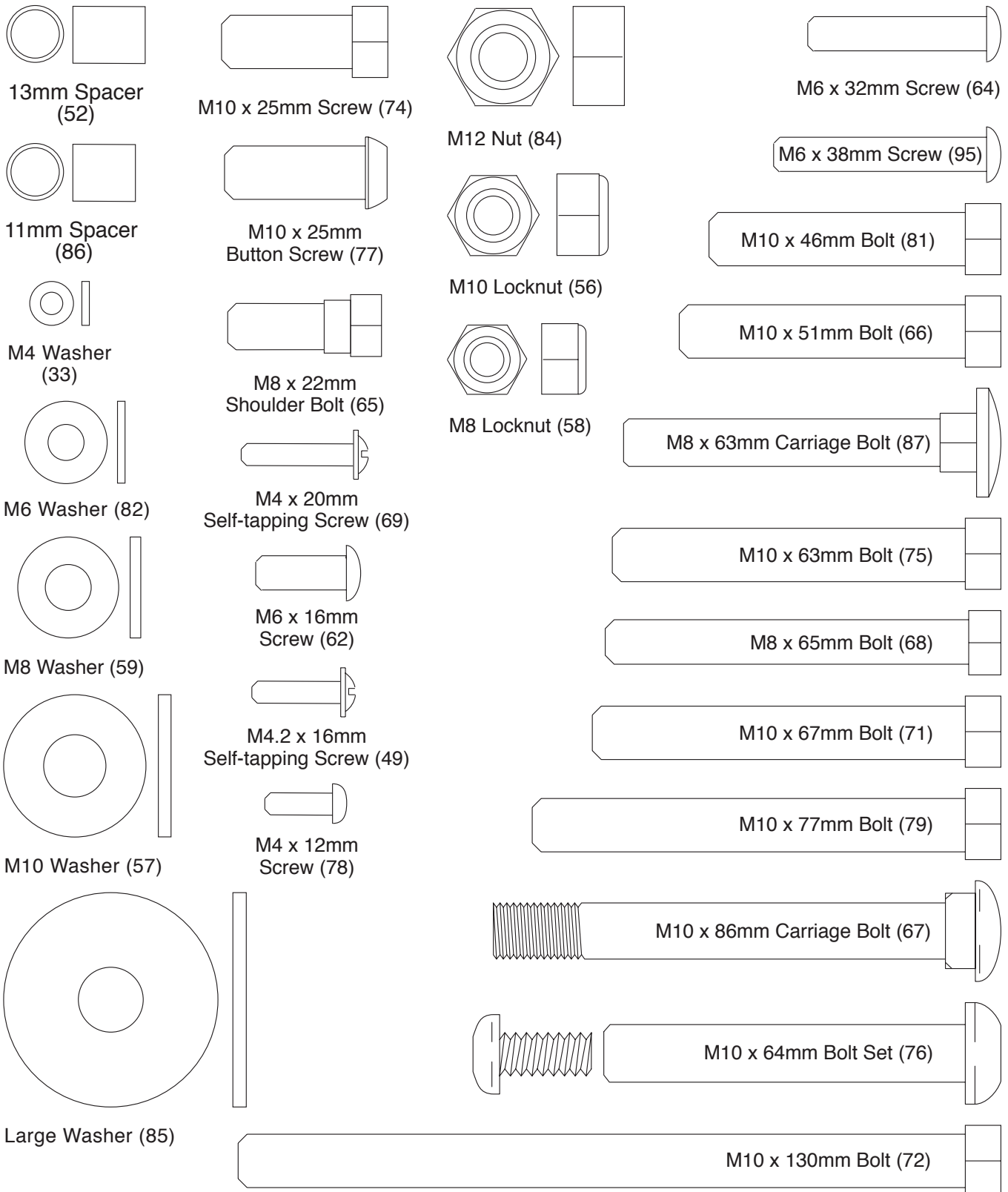

ASSEMBLY

- Assembly requires two persons.
- Because of its weight and size, assemble the weight system in the location where it will be used. Make sure that there is enough clearance to walk around the weight system.
- Place all parts in a cleared area and remove the packing materials. Do not dispose of the packing materials until assembly is completed.
- To identify small parts, see page 6.

- The following tool(s) (not included) may be required for assembly:

two adjustable wrenches



one rubber mallet



one standard screwdriver

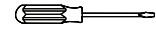

one Phillips screwdriver

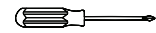

Assembly may be easier if you have a set of wrenches. To avoid damaging parts, do not use power tools.

The Four Stages of the Assembly Process

Frame Assembly—You will begin by assembling the base and the uprights that form the skeleton of the weight system.

Arm Assembly—During this stage you will assemble the arms and the leg lever.

Cable Assembly—During this stage you will attach the cables and pulleys that connect the arms to the weights.

Seat Assembly—During the final stage you will assemble the seat and the backrest.

1. **Call or email Customer Service (see the front cover of this manual) today and register your product.**

- activates your warranty
- saves you time if you ever need to contact Customer Service
- allows us to notify you of upgrades and offers

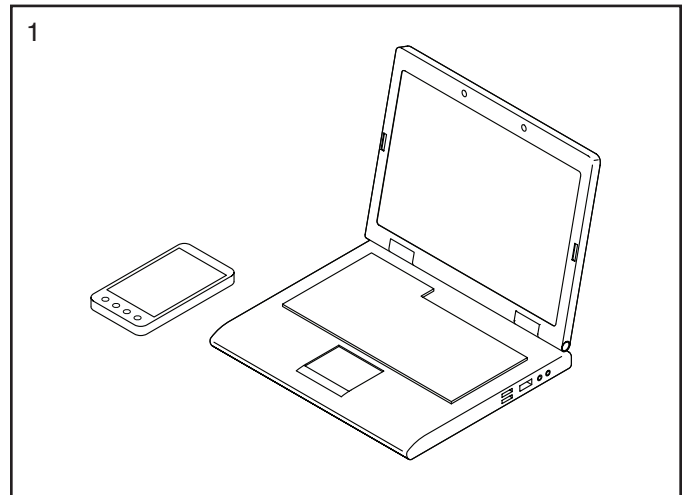

Frame Assembly

2. Attach the Foot Plate (38) to the Base (1) with an M10 x 130mm Bolt (72) and an M10 Locknut (56). **Do not overtighten the Locknut; the Foot Plate must pivot easily.**

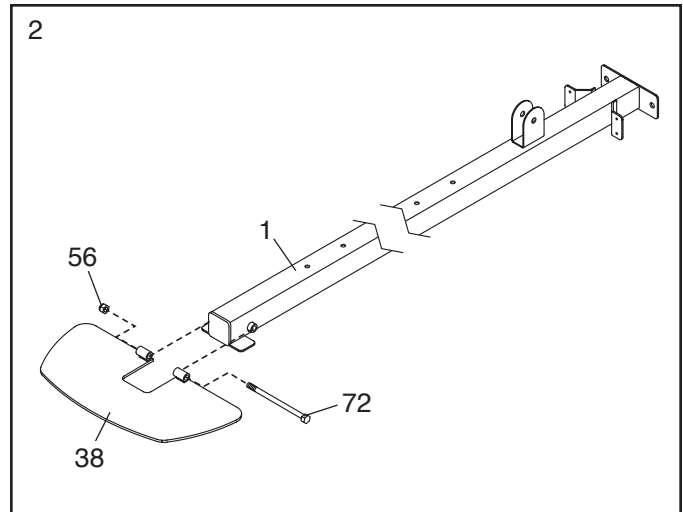

3. Attach the Weight Guides (21) and the Base (1) to the Stabilizer (2) with two M10 x 67mm Bolts (71), two M10 Washers (57), and two M10 Locknuts (56). **Do not tighten the Locknuts yet.**

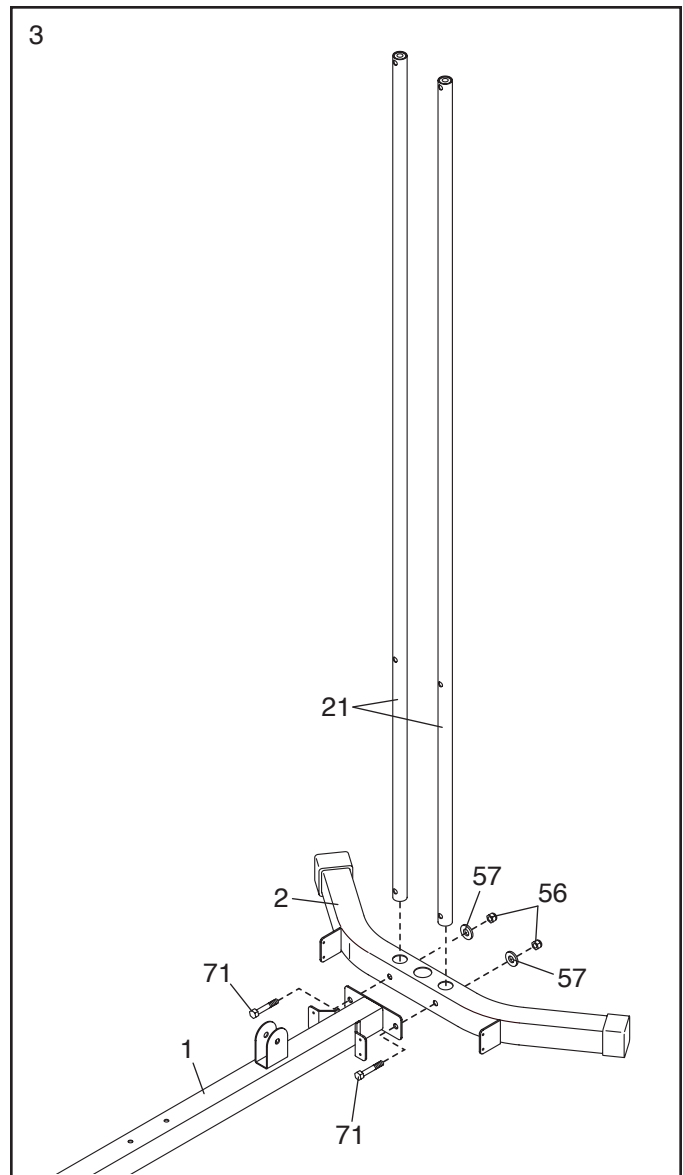

4. Attach the Upright (3) to the Base (1) with two M8 x 63mm Carriage Bolts (87) and two M8 Locknuts (58). **Do not tighten the Locknuts yet.**

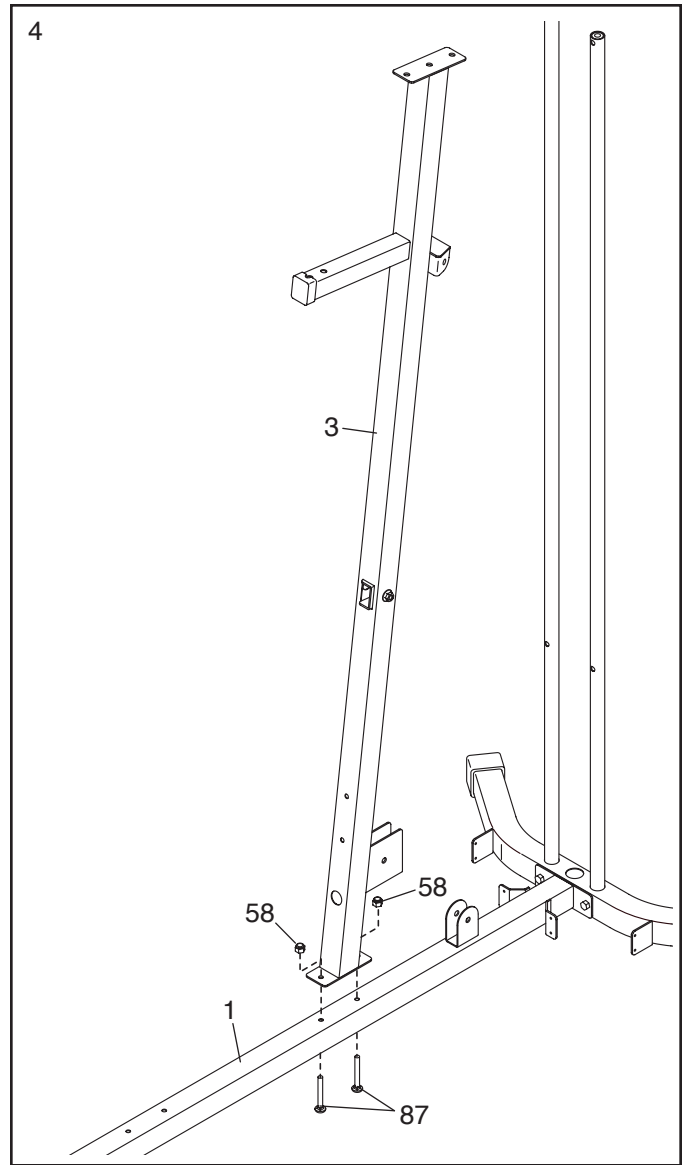

5. Attach the Front Leg (7) to the Base (1) with two M8 x 63mm Carriage Bolts (87) and two M8 Locknuts (58). **Do not tighten the Locknuts yet.**

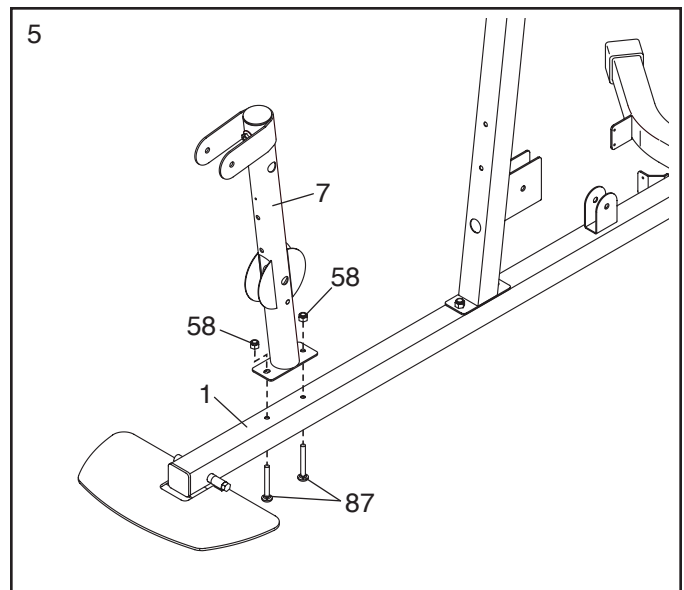

6. Attach the Seat Tube (6) to the Upright (3) with two M8 x 65mm Bolts (68), two M8 Washers (59), and two M8 Locknuts (58). **Do not tighten the Locknuts yet.**

Attach the Seat Tube (6) to the Front Leg (7) in the same way.

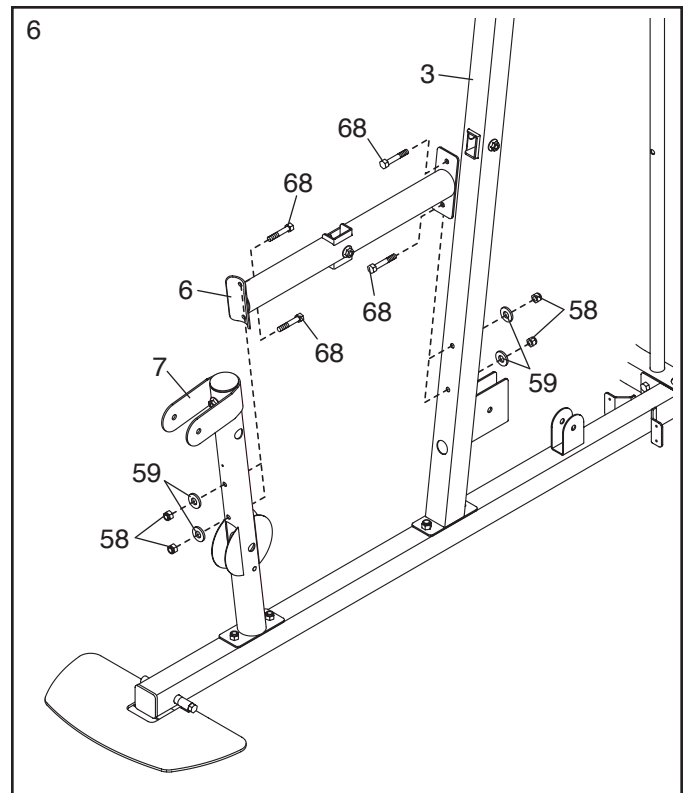

7. Slide the two Weight Bumpers (27) onto the Weight Guides (21).

Orient **nine** Weights (22) so that the pin holes are on the bottom as shown. Slide the Weights onto the Weight Guides (21).

Insert the Weight Selector (24) into the nine Weights (22). **Make sure that the pin on the Weight Selector is oriented as shown.**

Apply some of the included grease inside the indicated holes in the remaining Weight (22). Then, slide the Weight onto the Weight Guides (21).

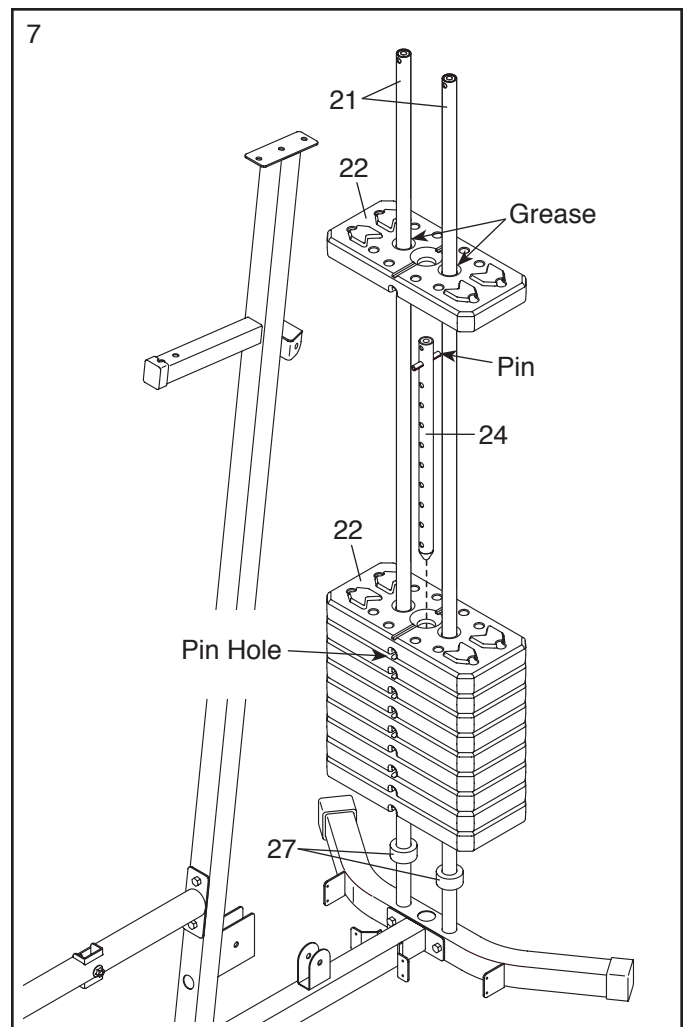

8. Attach the Top Frame (4) to the Upright (3) with two M10 x 67mm Bolts (71), two M10 Washers (57), and two M10 Locknuts (56). **Do not tighten the Locknuts yet.**

Attach the Top Frame (4) to the Weight Guides (21) with two M10 x 25mm Screws (74). **Do not tighten the Screws yet.**

See steps 3 to 8. Tighten the M10 Locknuts (56) and the M8 Locknuts (58).

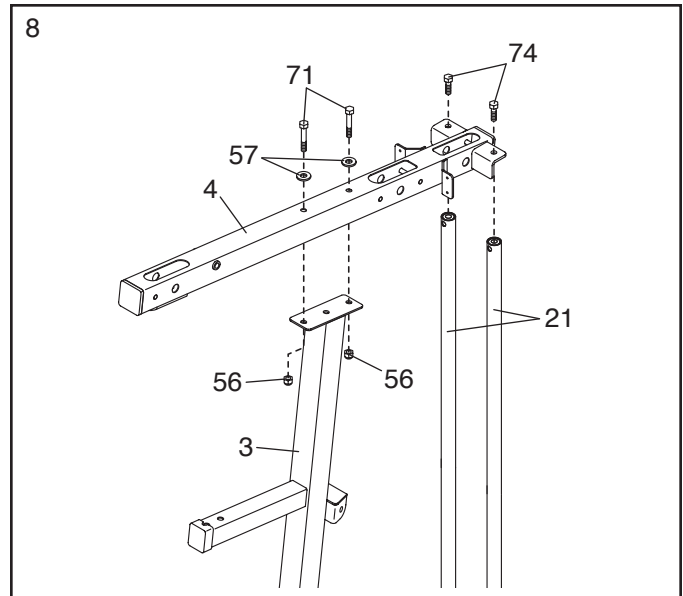

9. Attach the Leg Bumper (60) to the Front Leg (7) with an M4 x 20mm Self-tapping Screw (69) and an M4 Washer (33). **Make sure that the end of the Leg Bumper is pointing upward.**

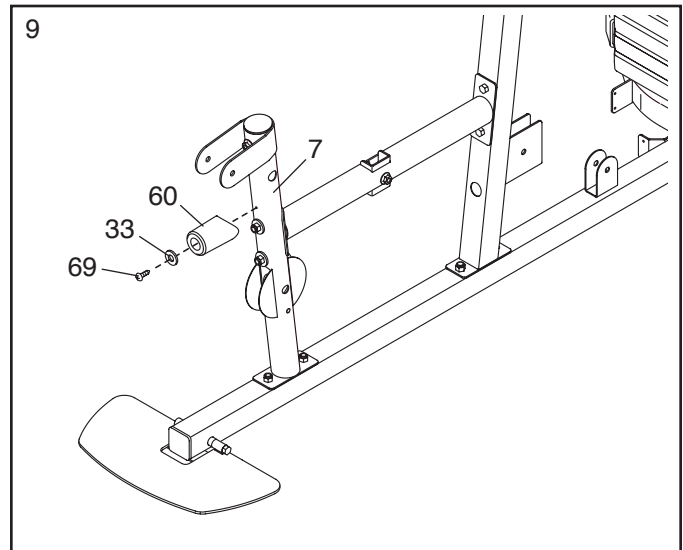

10. Apply grease to an M10 x 64mm Bolt Set (76).

Attach the Leg Lever (8) to the Front Leg (7) with the M10 x 64mm Bolt Set (76). **Make sure that the barrel of the Bolt Set is inserted through both sides of the bracket on the Front Leg.**

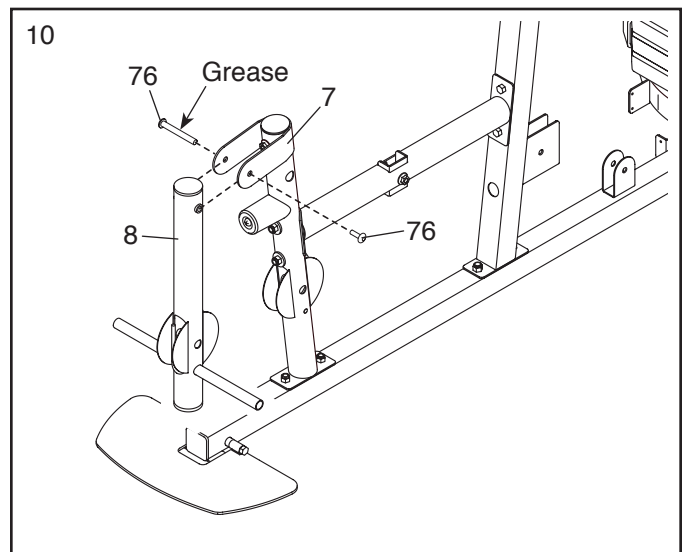

11. Apply grease to an M10 x 77mm Bolt (79).

Attach the Pivot Frame (5) to the Top Frame (4) with the M10 x 77mm Bolt (79) and an M10 Locknut (56). **Do not overtighten the Locknut; the Pivot Frame must pivot easily.**

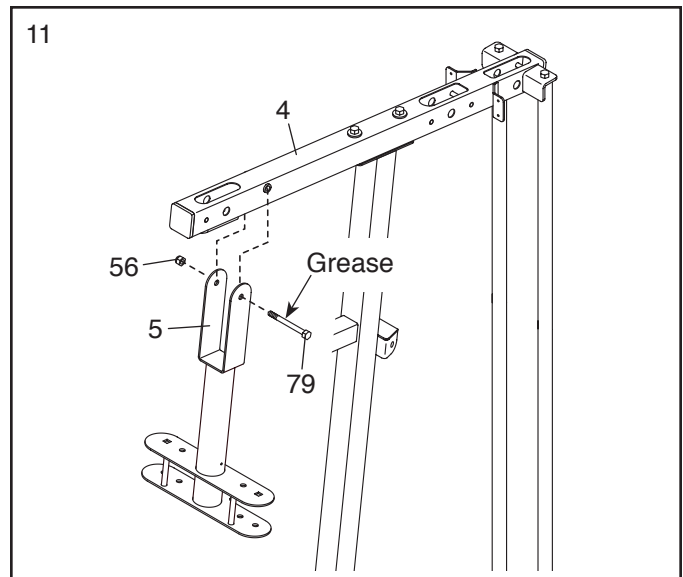

Arm Assembly

12. Attach the two Arm Pins (40) to the Pivot Frame (5) with two M4 x 20mm Self-tapping Screws (69).

See the inset drawing. Insert the Arm Pins (40) into the indicated holes in the Upright (3).

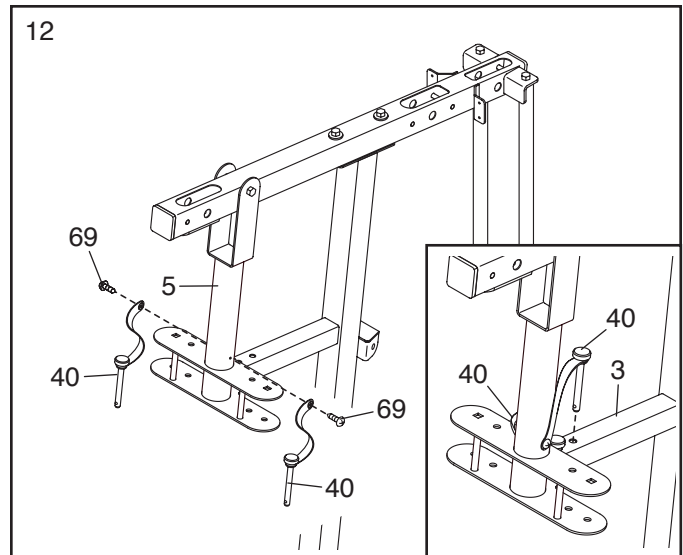

13. Apply grease to an M10 x 51mm Bolt (66).

Attach a Cable Pivot (39) to the Left Arm (10) with the M10 x 51mm Bolt (66) and an M10 Locknut (56). **Do not overtighten the Locknut; the Cable Pivot must pivot easily.**

Wet the inside of a Large Foam Pad (42) with soapy water. Slide the Large Foam Pad onto the Left Arm (10).

Attach a Handle (11) to the Left Arm (10) with two M10 x 25mm Button Screws (77) and two M10 Washers (57).

Assemble the Right Arm (9) in the same way.

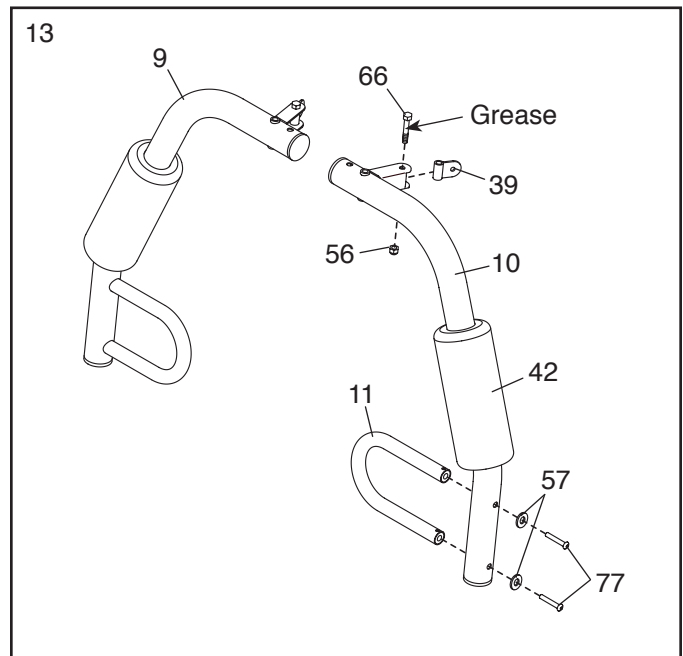

14. Apply grease to an M10 x 86mm Carriage Bolt (67) and to two Arm Bushings (44).

Attach the Left Arm (10) to the Pivot Frame (5) with the M10 x 86mm Carriage Bolt (67), a Carriage Bolt Bushing (20), the two Arm Bushings (44), an M10 Washer (57), and an M10 Locknut (56). **Do not overtighten the Locknut; the Left Arm must pivot easily.**

Attach the Right Arm (9) to the Pivot Frame (5) in the same way.

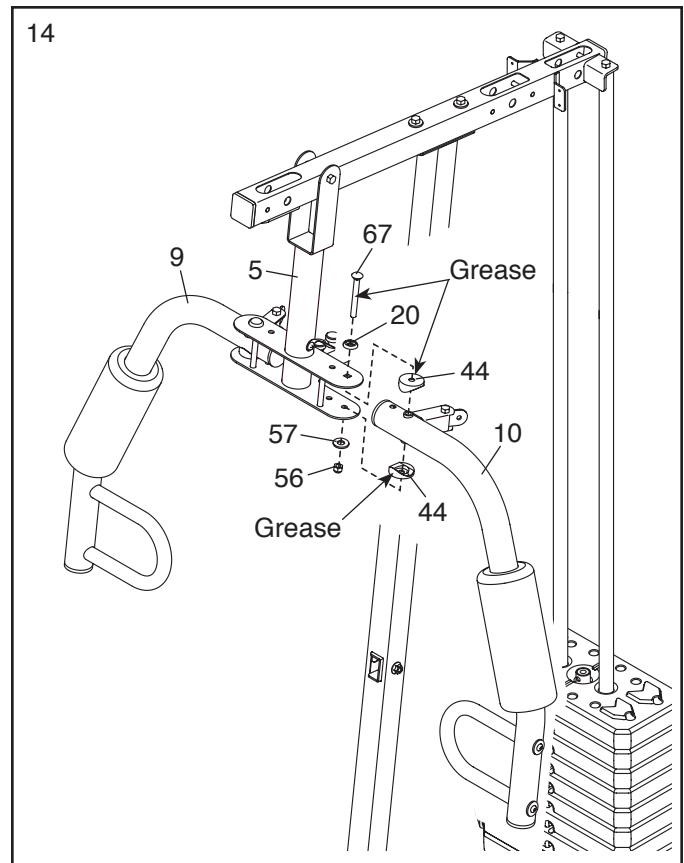

Cable Assembly

15. **IMPORTANT:** See the **CABLE DIAGRAM** on page 26. Cut along the dotted line, and lay the **CABLE DIAGRAM** beside this manual for reference while you assemble the cables and the pulleys.

Identify the Arm Cable (54).

Apply grease to an M8 x 22mm Shoulder Bolt (65).

Attach the Arm Cable (54) to the left Cable Pivot (39) with the M8 x 22mm Shoulder Bolt (65) and an M8 Locknut (58).

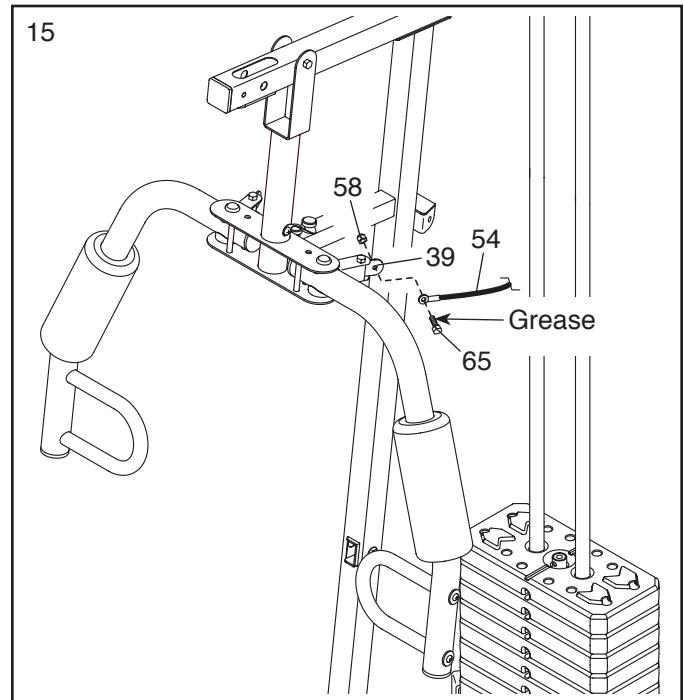

16. Identify the two V-pulleys (46), the nine Thick Pulleys (not shown), and the two Thin Pulleys (not shown).

Tip: It may be helpful to refer to the **EXPLODED DRAWING** near the end of this manual to identify the pulleys.

Route the Arm Cable (54) over a V-pulley (46).

Attach the V-pulley (46), a Large Cable Trap (50), two Full Guards (41), and an M10 Washer (57) to the Upright (3) with an M10 x 63mm Bolt (75) and an M10 Locknut (56).

Make sure that the Large Cable Trap (50) is oriented to hold the Arm Cable (54) in the groove of the V-pulley (46).

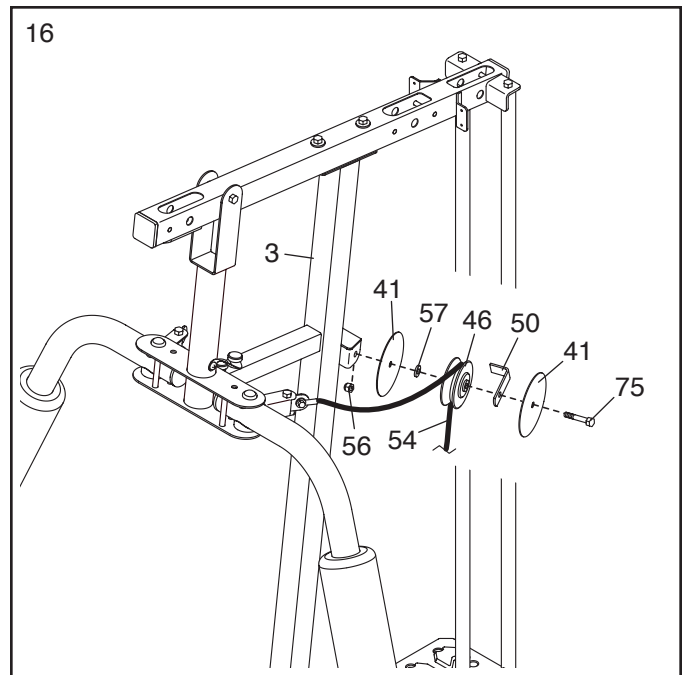

17. Route the Arm Cable (54) around a Thick Pulley (48).

Attach the Thick Pulley (48) and two Half Guards (43) to the Double U-bracket (63) with an M10 x 46mm Bolt (81) and an M10 Locknut (56). **Make sure that the Half Guards are on the outside of the Double U-bracket as shown.**

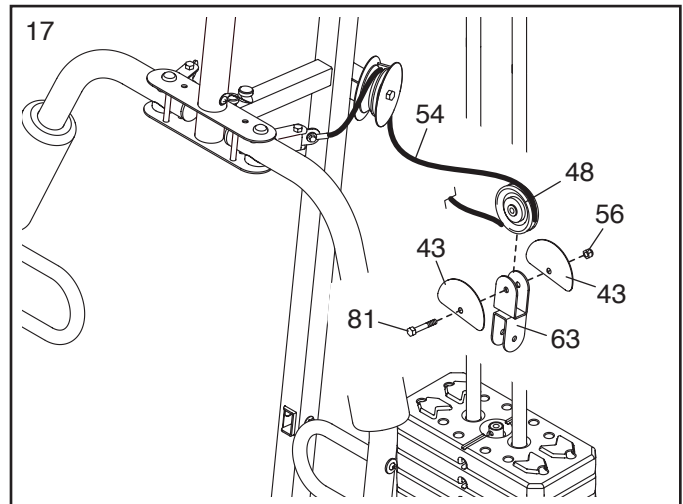

18. Route the Arm Cable (54) over a V-pulley (46).

Attach the V-pulley (46), a Large Cable Trap (50), two Full Guards (41), and an M10 Washer (57) to the Upright (3) with an M10 x 63mm Bolt (75) and an M10 Locknut (56).

Make sure that the Large Cable Trap (50) is oriented to hold the Arm Cable (54) in the groove of the V-pulley (46).

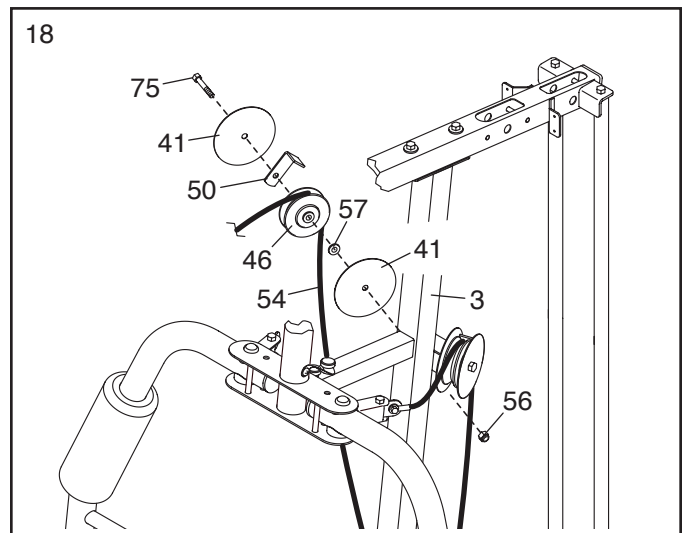

19. Apply grease to an M8 x 22mm Shoulder Bolt (65).

Attach the Arm Cable (54) to the right Cable Pivot (39) with the M8 x 22mm Shoulder Bolt (65) and an M8 Locknut (58).

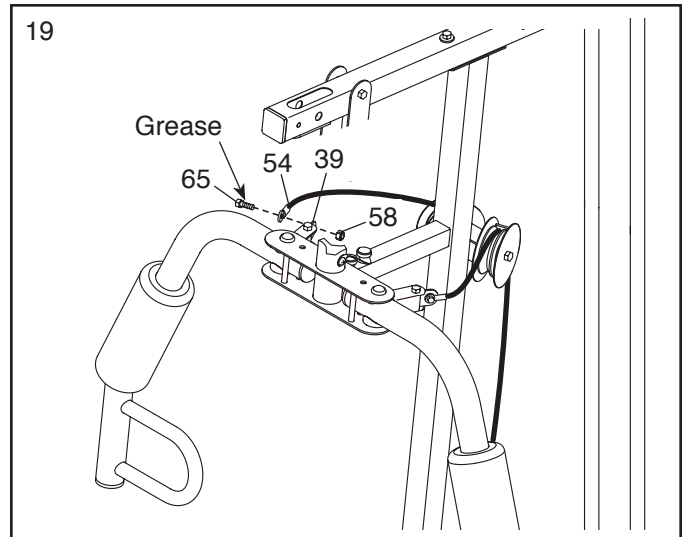

20. See the CABLE DIAGRAM. Identify the Low Cable (53).

Route the Low Cable (53) through the Leg Lever (8) and the Front Leg (7).

Attach a Thick Pulley (48) inside the Leg Lever (8), above the Low Cable (53), with an M10 x 67mm Bolt (71), two M10 Washers (57), two 13mm Spacers (52), and an M10 Locknut (56).

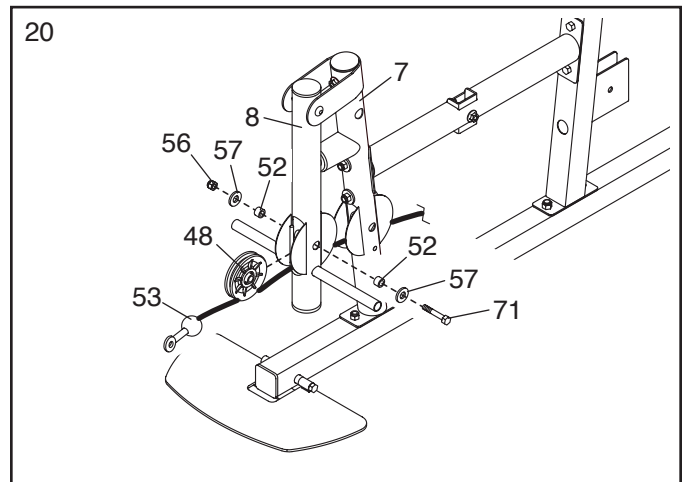

21. Attach a Thick Pulley (48) inside the Front Leg (7), above the Low Cable (53), with an M10 x 67mm Bolt (71), two M10 Washers (57), two 13mm Spacers (52), and an M10 Locknut (56).

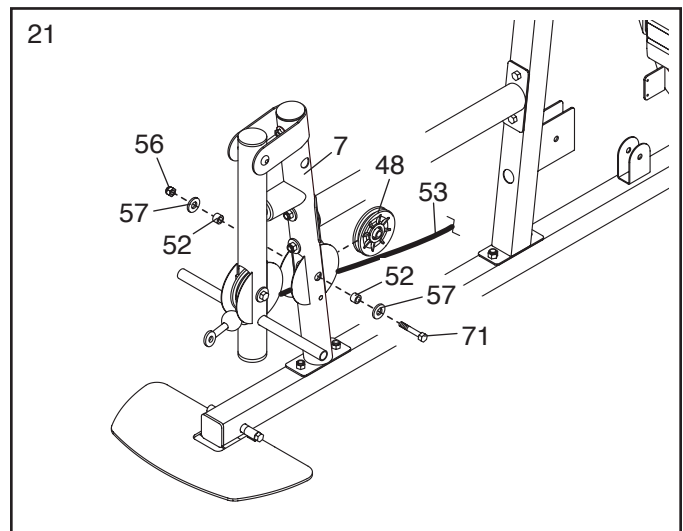

22. Route the Low Cable (53) through the Upright (3) and under a Thick Pulley (48).

Attach the Thick Pulley (48) inside the Upright (3) with an M10 x 46mm Bolt (81) and an M10 Locknut (56).

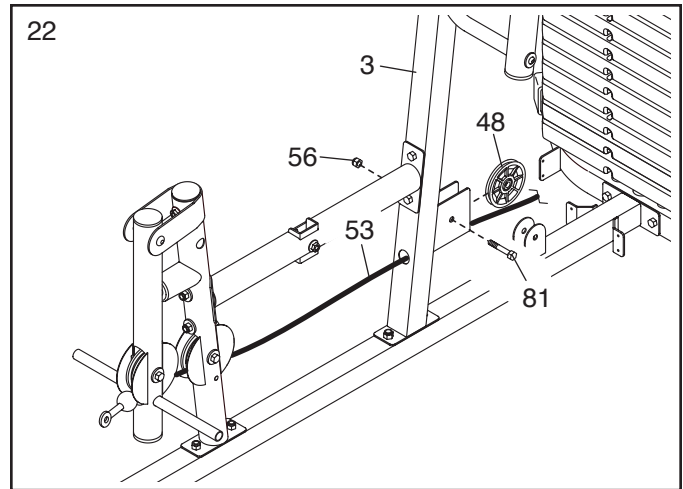

23. Route the Low Cable (53) over a Thick Pulley (48).

Attach the Thick Pulley (48) and two Half Guards (43) to the Double U-bracket (63) with an M10 x 46mm Bolt (81) and an M10 Locknut (56). **Make sure that the Half Guards are on the outside of the Double U-bracket as shown.**

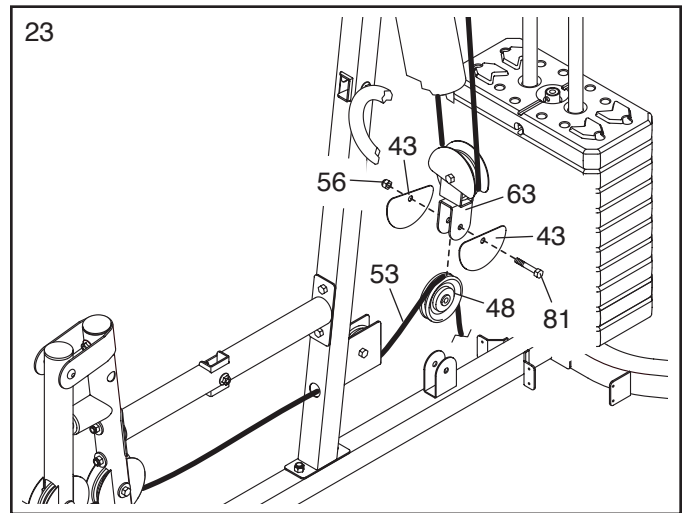

24. Route the Low Cable (53) under a Thick Pulley (48).

Attach the Thick Pulley (48) and two Half Guards (43) to the Base (1) with an M10 x 46mm Bolt (81) and an M10 Locknut (56). **Make sure that the Half Guards are on the outside of the bracket as shown.**

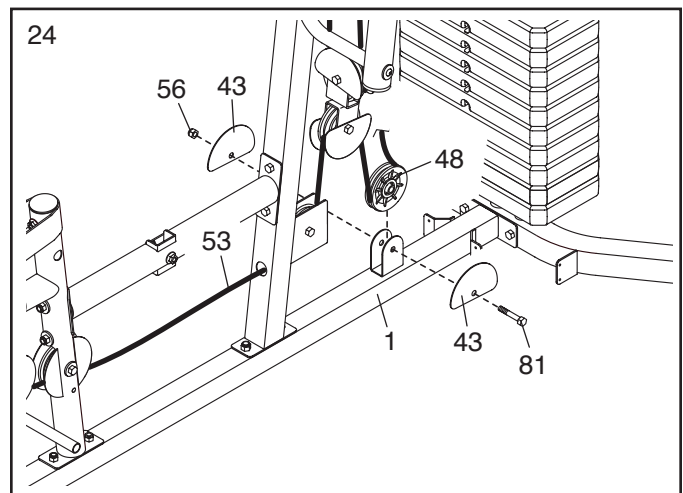

25. Attach the Low Cable (53) to the U-bracket (45) with an M8 Washer (59) and an M8 Locknut (58).

See the inset drawing. Do not overtighten the M8 Locknut (58); it should be threaded onto the end of the Low Cable (53) so that only two threads are showing above the Locknut.

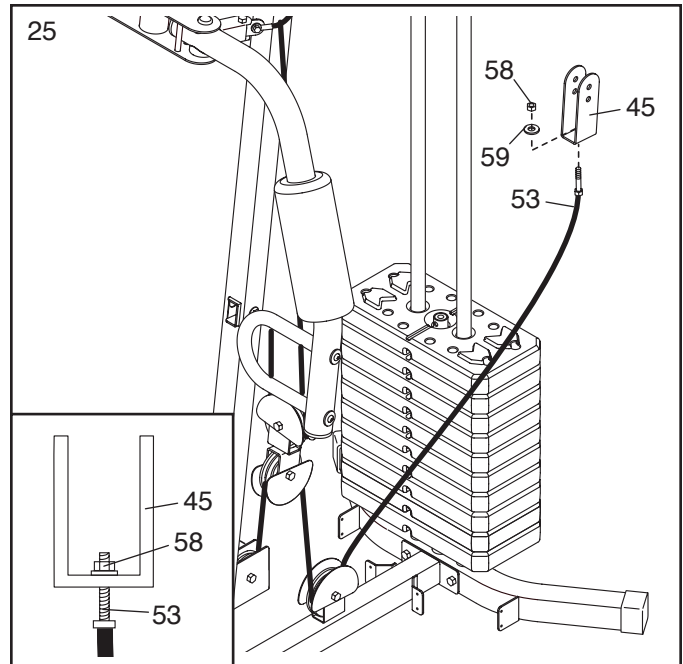

26. **See the CABLE DIAGRAM. Identify the High Cable (55).**

Route the High Cable (55) upward through the Top Frame (4) and over a Thick Pulley (48). **Make sure that the eyelet end of the High Cable is in the indicated location.**

Attach the Thick Pulley (48) inside the Top Frame (4) with an M10 x 67mm Bolt (71), two M10 Washers (57), two 13mm Spacers (52), and an M10 Locknut (56).

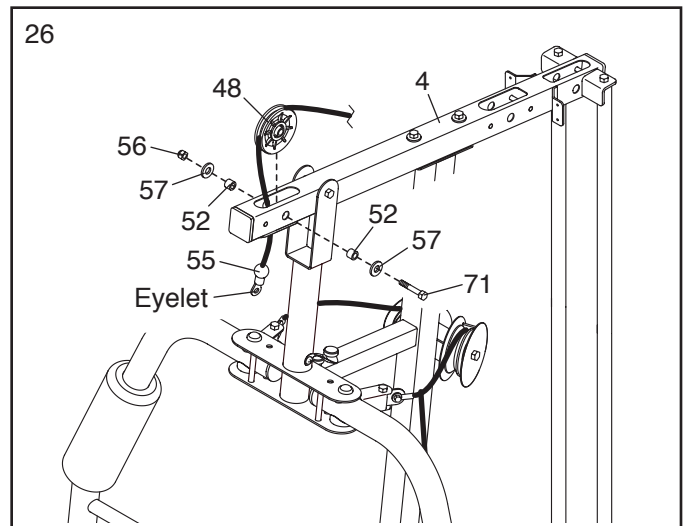

27. Route the High Cable (55) over a Thin Pulley (47) and downward through the Top Frame (4).

Attach the Thin Pulley (47) **inside** the Top Frame (4) with an M10 x 67mm Bolt (71), an M10 Washer (57), and an 11mm Spacer (86). **Make sure that the Thin Pulley does not fall out of the Top Frame while you complete steps 28 and 29.**

Note: Another Thin Pulley (not shown) will be installed inside the Top Frame (4) with the same M10 x 67mm Bolt (71) in step 29.

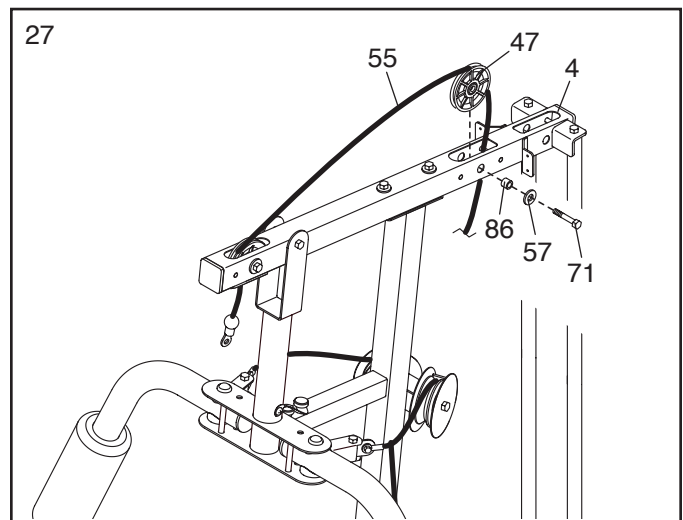

28. Wrap the High Cable (55) under a Thick Pulley (48).

Attach the Thick Pulley (48), a Small Cable Trap (51), and two Half Guards (43) to the upper hole in the U-bracket (45) with an M10 x 51mm Bolt (66) and an M10 Locknut (56).

Make sure that the Small Cable Trap (51) is oriented to hold the High Cable (55) in the groove of the Thick Pulley (48) and that the Half Guards (43) are on the outside of the U-bracket (45).

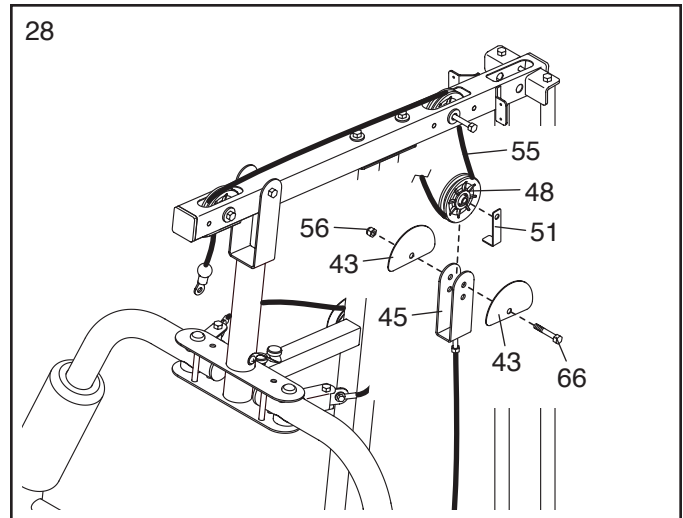

29. Route the High Cable (55) upward through the Top Frame (4) and over a Thin Pulley (47).

Attach the Thin Pulley (47) **inside** the Top Frame (4) with the M10 x 67mm Bolt (71) used in step 27, an 11mm Spacer (86), an M10 Washer (57), and an M10 Locknut (56).

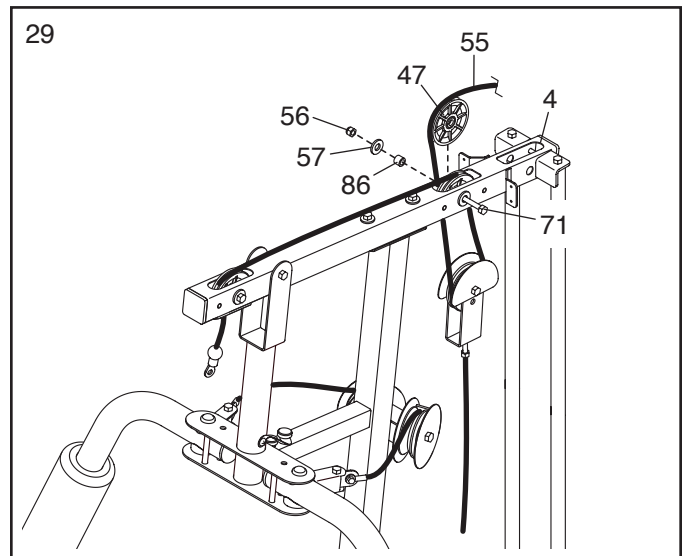

30. Route the High Cable (55) over a Thick Pulley (48) and downward through the Top Frame (4).

Attach the Thick Pulley (48) inside the Top Frame (4) with an M10 x 67mm Bolt (71), two M10 Washers (57), two 13mm Spacers (52), and an M10 Locknut (56).

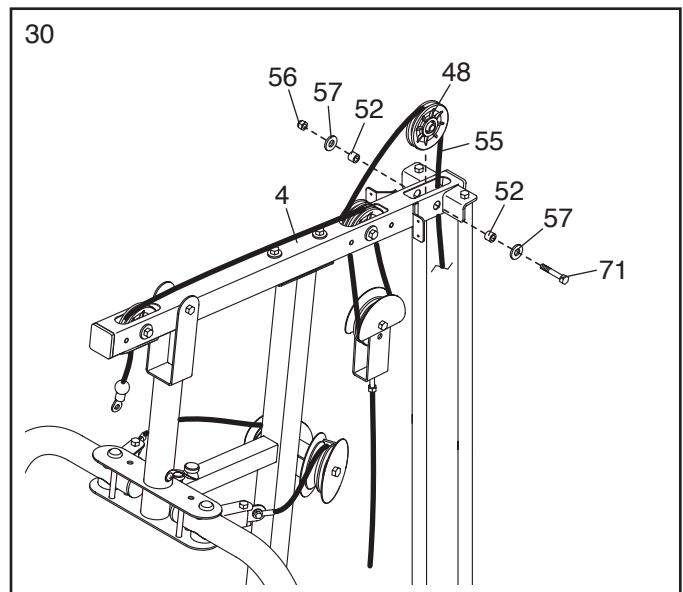

31. Thread an M12 Nut (84) all the way onto the High Cable (55). Then, place a Large Washer (85) on top of the Weight Selector (24).

Tighten the High Cable (55) into the Weight Selector (24) until all the slack is removed from the cables.

Tighten the M12 Nut (84) against the Large Washer (85).

Tip: If the High Cable (55) does not reach to the Weight Selector (24), see step 25. If more than two threads of the Low Cable (53) are showing above the M8 Locknut (58), adjust the Locknut so that only two threads of the Low Cable are showing.

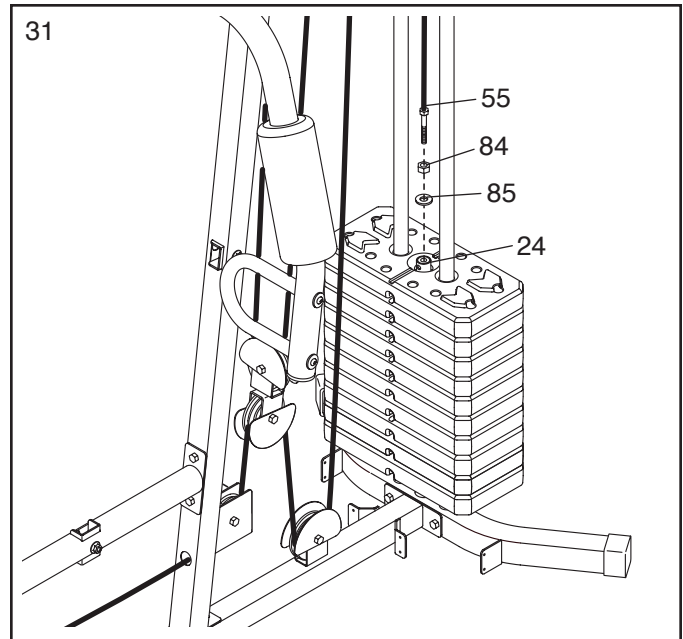

Seat Assembly

32. Attach the Backrest (16) to the Backrest Frame (61) with two M6 x 16mm Screws (62), an M6 x 32mm Screw (64), and an M6 Washer (82).

Insert the Backrest Frame (61) into the Upright (3) and tighten a Long Knob (91) into the Upright and one of the holes in the Backrest Frame.

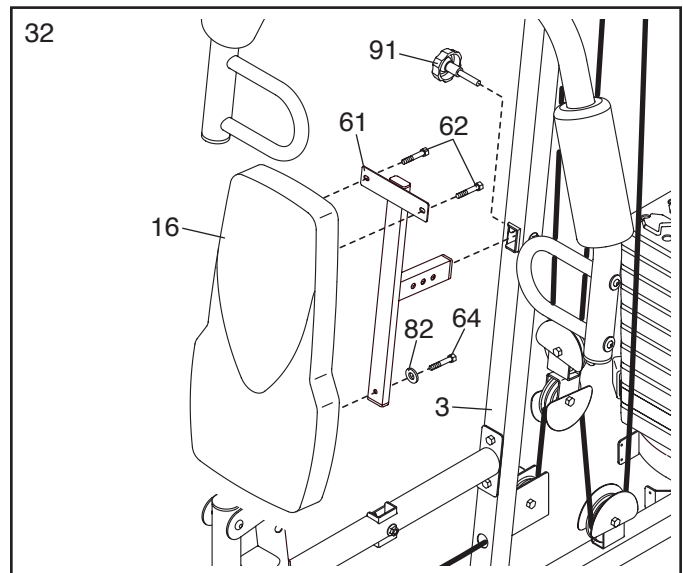

33. Attach the Seat (15) to the Seat Frame (73) with two M6 x 16mm Screws (62), an M6 x 38mm Screw (95), and an M6 Washer (82).

Insert the Seat Frame (73) into the Seat Tube (6) and tighten a Long Knob (91) into the Seat Tube and one of the holes in the Seat Frame.

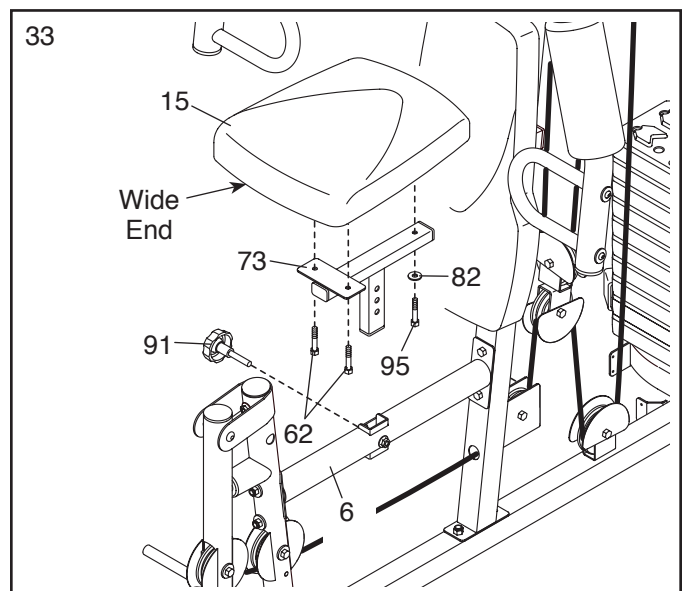

34. Insert the Pad Tube (29) into the Front Leg (7).

Slide a Small Foam Pad (28) onto each side of the Pad Tube (29). Then, press a Pad Cap (34) into each Small Foam Pad.

Slide a Small Foam Pad (28) onto each end of the Leg Lever (8). Then, press a Pad Cap (34) into each Small Foam Pad.

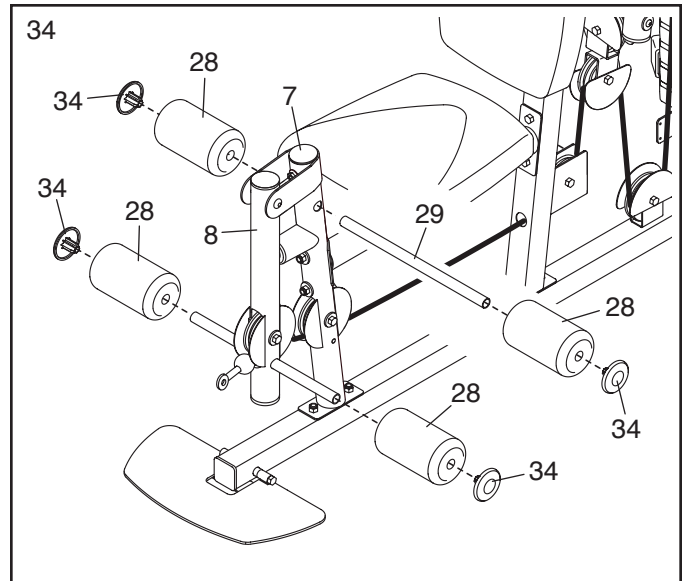

35. Attach a Shroud Support (19) and the top of the Left Shroud (17) to the left side of the Top Frame (4) with two M4.2 x 16mm Self-tapping Screws (49) and two M4 Washers (33). **Do not tighten the Screws yet.**

Then, attach a Shroud Clamp (90) to the top of the Left Shroud (17) and the Shroud Support (19) with two M4 x 12mm Screws (78) and two M4 Washers (33). **Do not tighten the Screws yet.**

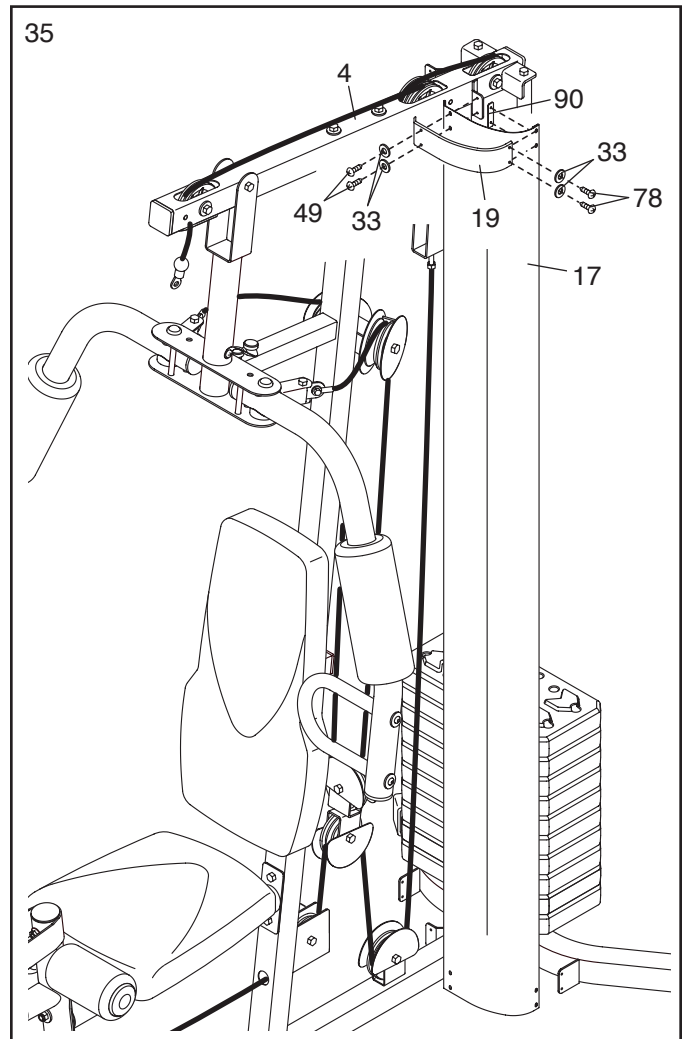

36. Attach a Shroud Support (19) and the bottom of the Left Shroud (17) to the Base (1) and the Stabilizer (2) with four M4.2 x 16mm Self-tapping Screws (49) and four M4 Washers (33). **Do not tighten the Screws yet.**

Repeat steps 35 and 36 to attach the Right Shroud (not shown).

See steps 35 and 36. Tighten the M4.2 x 16mm Self-tapping Screws (49) and the M4 x 12mm Screws (78).

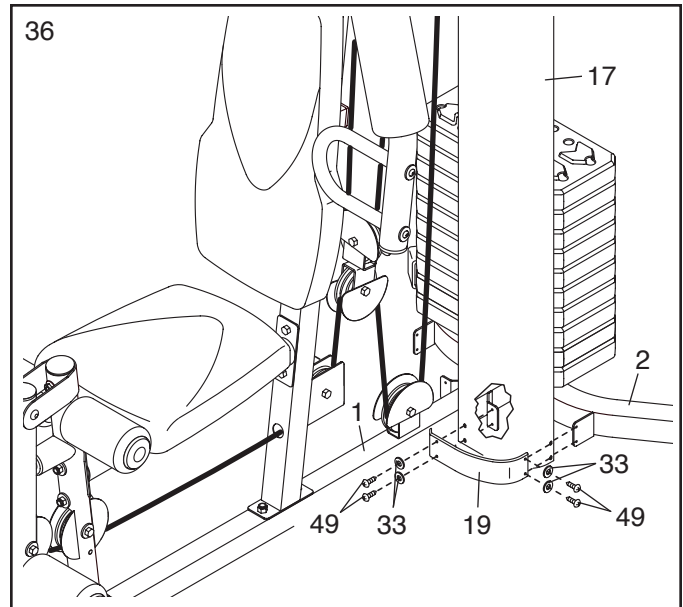

37. Attach the Curl Pad (14) to the Curl Post (13) with two M6 x 16mm Screws (62).

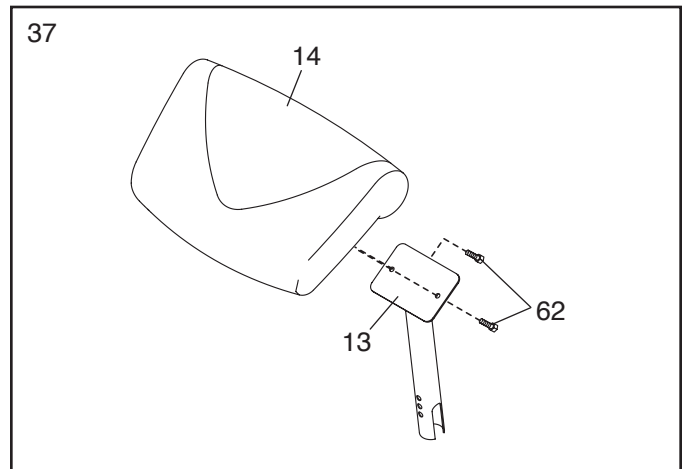

38. Make sure that all parts have been properly tightened. The use of the remaining parts will be explained in ADJUSTMENT, beginning on page 22.

Before using the weight system, pull each cable a few times to make sure that the cables move smoothly around the pulleys. If one of the cables does not move smoothly, find and correct the problem.

IMPORTANT: If the cables are not properly installed, they may be damaged when heavy weight is used. See the **CABLE DIAGRAM** on page 26 for proper cable routing. If there is any slack in the cables, you will need to remove the slack by tightening the cables. See **MAINTENANCE** on page 25.

ADJUSTMENT

This section explains how to adjust the weight system. See the EXERCISE GUIDELINES on page 27 for important information about how to get the most benefit from your exercise program. Also, refer to the accompanying exercise guide to see the correct form for several exercises.

Make sure that all parts are properly tightened each time the weight system is used. Replace any worn parts immediately.

CHANGING THE WEIGHT SETTING

To change the setting of the weight stack, insert a Weight Pin (26) under the desired Weight (22). Insert the Weight Pin so that the bent end touches the weight stack. Turn the bent end downward.

Note: Due to the cables and pulleys, the amount of resistance at each exercise station may vary from the weight setting. Use the WEIGHT RESISTANCE CHART on page 24 to find the approximate amount of resistance at each weight station.

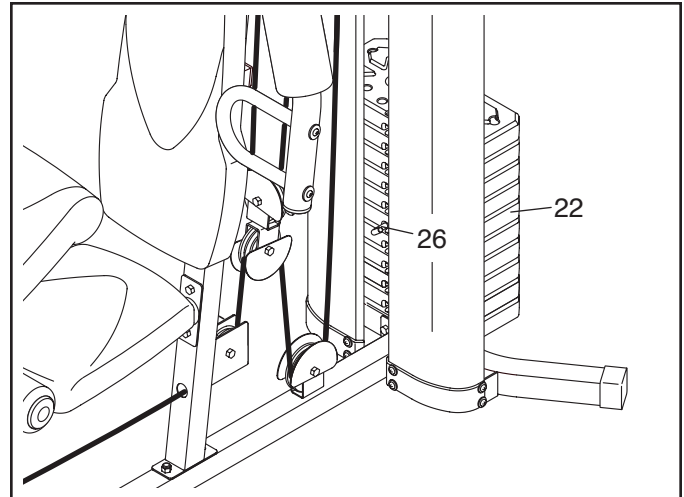

ATTACHING THE ACCESSORIES

Attach the Lat Bar (35) to the High Cable (55) at the high pulley station with a Cable Clip (37).

For some exercises, attach the Chain (83) between the Lat Bar (35) and the High Cable (55) with two Cable Clips (37). **Adjust the length of the Chain between the Lat Bar and the High Cable so that the Lat Bar is in the correct starting position for the exercise to be performed.**

The Lat Bar (35) or the Handle Strap (not shown) can be attached at either pulley station in the same way.

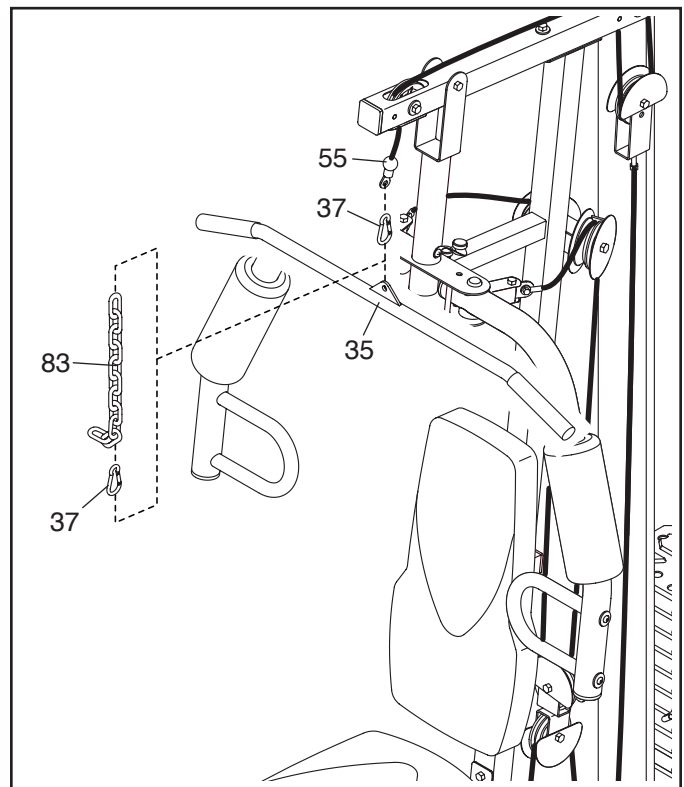

CONVERTING THE ARMS

To use the Arms (9, 10) as butterfly arms, insert the Arm Pins (40) into the holes in the Upright (3) as shown.

To use the Arms (9, 10) as press arms, insert the Arm Pins (40) into the holes in the Pivot Frame (5) and the Arms.

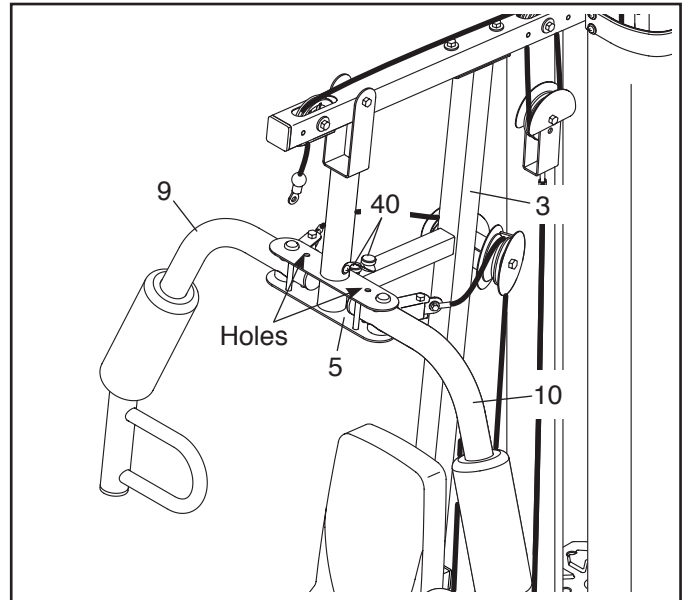

CONVERTING THE FOOT PLATE

To use the Foot Plate (38) as a footrest while using the low pulley station, rotate the Foot Plate upward.

When you are not using the Foot Plate (38) as a footrest, rotate the Foot Plate downward so that it is flat on the floor.

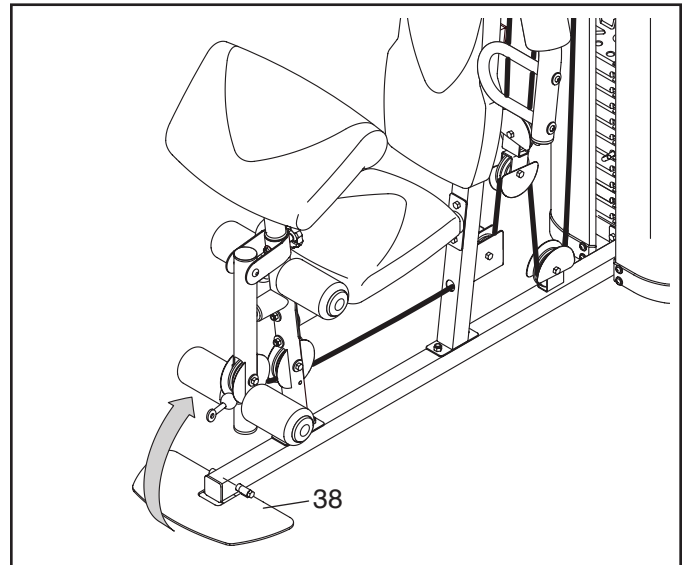

USING THE CURL PAD

To use the Curl Pad (14), first remove the 50mm Round Inner Cap (30) from the Front Leg (7). Insert the Curl Post (13) into the Front Leg and secure it in place with the Short Knob (25).

Remove the Curl Pad (14) when it is not in use. When performing an exercise that does not require the Curl Pad, remove the Curl Pad. After you remove the Curl Pad, replace the 50mm Round Inner Cap (30) into the Front Leg (7). Store the Curl Pad away from the weight system.

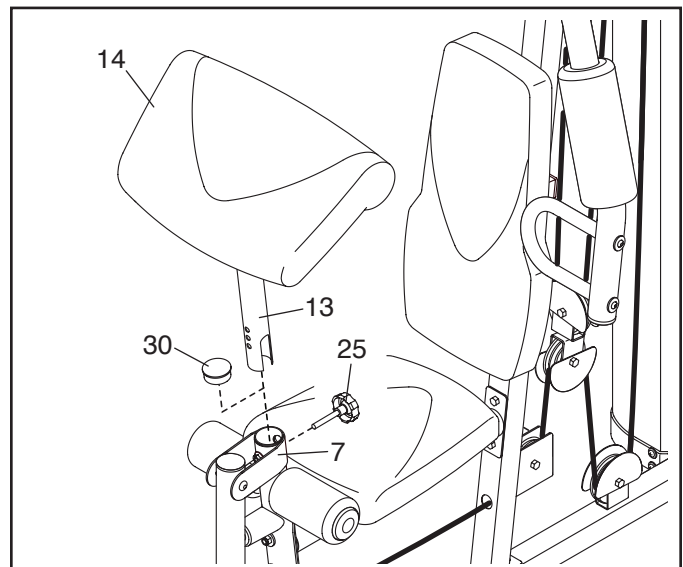

LOCKING THE WEIGHT STACK

To lock the weight stack after each workout, insert the Lock Pin (89) through one of the Weight Guides (21), and secure the Lock (88) on the Lock Pin.

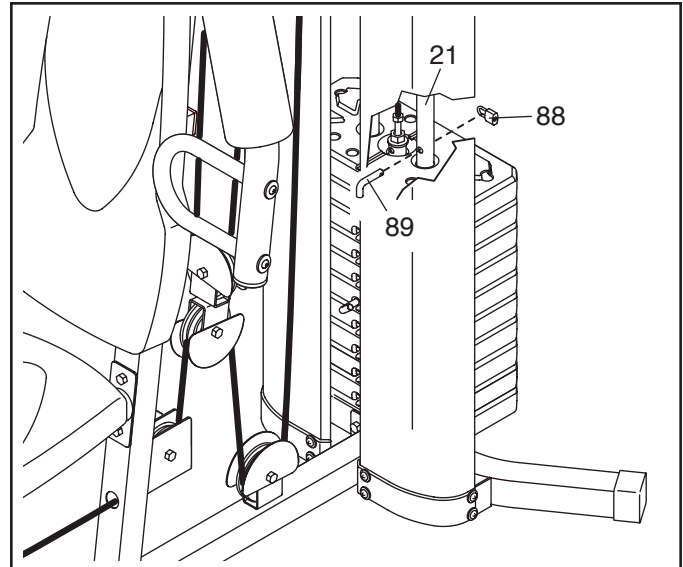

WEIGHT RESISTANCE CHART

The chart below shows the approximate weight resistance at each exercise station. The numbers in the left column refer to the 12.5-lb. weights. **Note: The weight resistance shown for the butterfly arm station is for each arm. The actual resistance at each station may vary due to differences in individual weights as well as friction between the cables, pulleys, and weight guides.**

WEIGHT	BUTTERFLY ARM (lbs.)	PRESS ARM (lbs.)	HIGH PULLEY (lbs.)	LEG LEVER (lbs.)	LOW PULLEY (lbs.)
1	19	53	22	63	57
2	24	78	36	104	84
3	32	100	53	132	112
4	40	116	64	153	140
5	44	140	79	180	173
6	50	165	93	201	198
7	57	190	107	239	227
8	65	218	118	276	259
9	74	240	131	303	288
10	79	276	145	330	320

Note: 1 lb. = 0.45 kg

MAINTENANCE

Make sure that all parts are properly tightened each time the weight system is used. Replace any worn parts immediately. To clean the weight system, use a damp cloth and a mild, non-abrasive detergent; **do not use solvents to clean the weight system.**

TIGHTENING THE CABLES

Woven cable, the type of cable used on the weight system, can stretch slightly when it is first used. If there is slack in the cables before resistance is felt, the cables should be tightened. To tighten the cables, first insert the weight pin into the middle of the weight stack. Slack can be removed from the cables several ways:

See the inset drawing. Tighten the M8 Locknut (58) that connects the end of the Low Cable (53) to the U-bracket (45).

Remove the M10 Locknut (56) and the M10 x 51mm Bolt (66) from the two Half Guards (43), the U-bracket (45), the Small Cable Trap (51), and the Thick Pulley (48).

Reattach the Thick Pulley (48), Small Cable Trap (51), and Half Guards (43) to the other hole in the U-bracket (45). **Make sure that the Small Cable Trap is in the proper position and that the Low Cable (53) and the Thick Pulley move smoothly.**

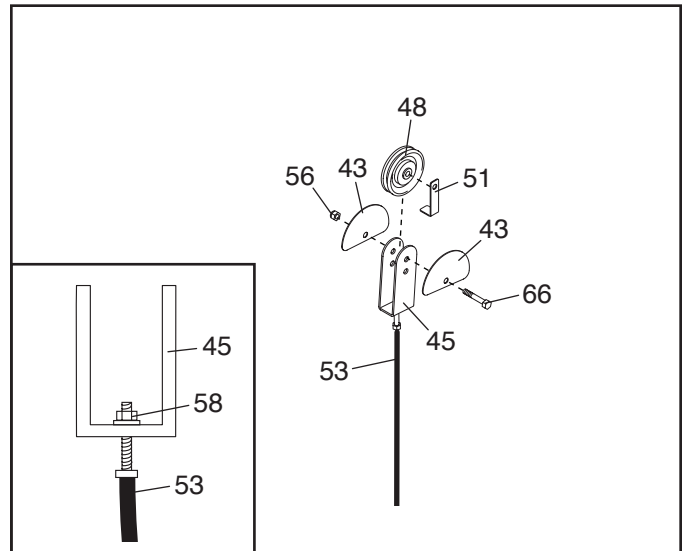

Loosen the M12 Nut (84) on the High Cable (55).

Tighten the High Cable (55) into the Weight Selector (24) until the slack is removed from the High Cable.

Then, retighten the M12 Nut (84) against the Large Washer (85).

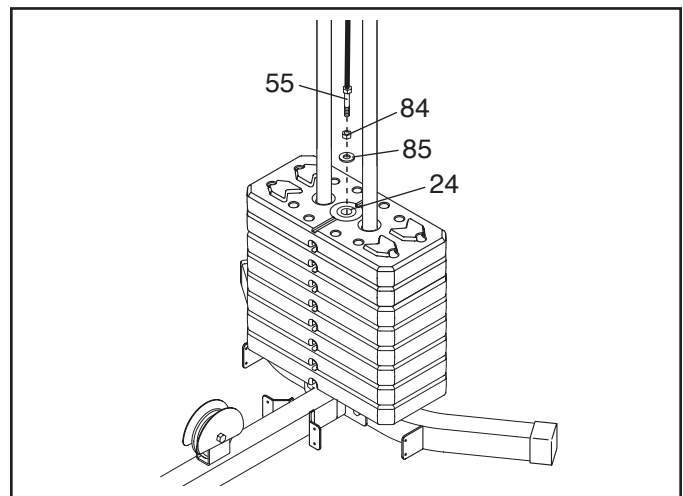

Do not overtighten the cables. If the cables are overtightened, the top weight will be lifted off the weight stack. If a cable tends to slip off the pulleys often, it may have become twisted. Remove the cable and reinstall it. If the cables need to be replaced, see the back cover of this manual.

CABLE DIAGRAM

The diagram below shows the proper routing of the cables. The numbers in each drawing show the proper route of that cable. Cut along the dotted line, and refer to this diagram while you assemble the cables and the pulleys. If the cables and the pulleys are not assembled correctly, the weight system will not function properly and damage may occur. **Make sure that the cable traps do not touch or bind the cables. After you assemble the weight system, save this diagram with this manual for future reference.**

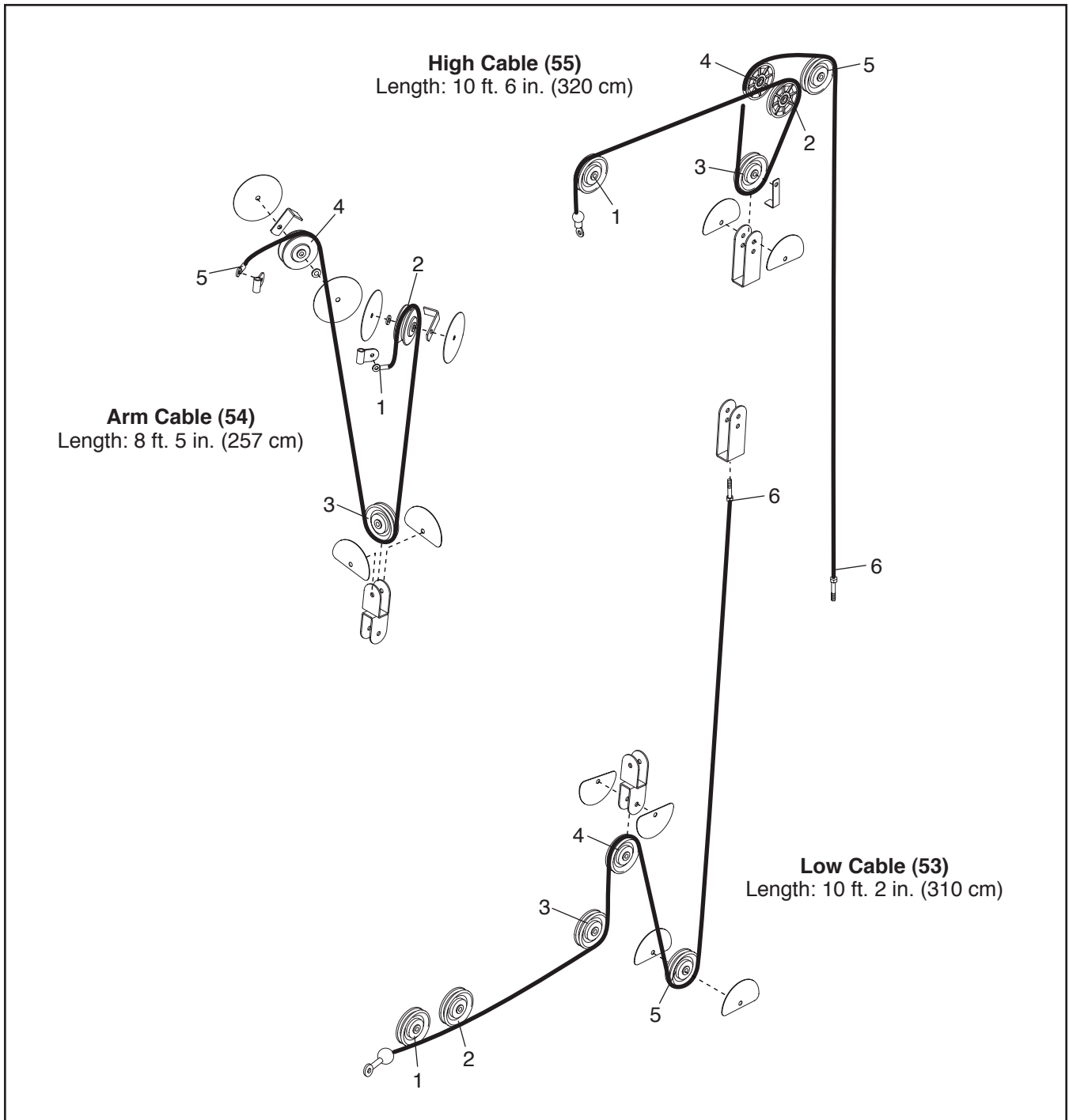

EXERCISE GUIDELINES

FOUR TYPES OF STRENGTH WORKOUTS

Note: A “repetition” is one complete cycle of an exercise, such as one sit-up. A “set” is a series of repetitions.

Muscle Building—Work your muscles near their maximum capacity and progressively increase the intensity of your exercise. Adjust the intensity level of an individual exercise as follows:

- Change the amount of resistance used.
- Change the number of repetitions or sets performed.

Use your own judgment to determine the amount of resistance that is right for you. Begin with 3 sets of 8 repetitions for each exercise you perform. Rest for 3 minutes after each set. When you can complete 3 sets of 12 repetitions without difficulty, increase the amount of resistance.

Toning—Tone your muscles by working them to a moderate percentage of their capacity. Select a moderate amount of resistance and increase the number of repetitions in each set. Complete as many sets of 15 to 20 repetitions as possible without discomfort. Rest for 1 minute after each set. Work your muscles by completing more sets rather than by using high amounts of resistance.

Weight Loss—To lose weight, use a low amount of resistance and increase the number of repetitions in each set. Exercise for 20 to 30 minutes, resting for a maximum of 30 seconds between sets.

Cross Training—Combine strength training and aerobic exercise by following this type of program:

- Strength training workouts on Monday, Wednesday, and Friday.
- 20 to 30 minutes of aerobic exercise on Tuesday and Thursday.
- One full day of rest each week to give your body time to regenerate.

WORKOUT GUIDELINES

Familiarize yourself with the equipment and learn the proper form for each exercise. Use your own judgment to determine the appropriate length of time for each

workout, and the numbers of repetitions and sets to complete. Progress at your own pace and be sensitive to your body’s signals. Follow each workout with at least one day of rest.

Warming Up—Start with 5 to 10 minutes of stretching and light exercise. A warm-up increases your body temperature, heart rate, and circulation in preparation for exercise.

Working Out—Include 6 to 10 different exercises in each workout. Select exercises for every major muscle group, emphasizing areas that you want to develop. To give balance and variety to your workouts, vary the exercises from workout to workout.

Cooling Down—Finish with 5 to 10 minutes of stretching. Stretching increases the flexibility of your muscles and helps to prevent post-exercise problems.

EXERCISE FORM

Move through the full range of motion for each exercise and move only the appropriate parts of the body. Perform the repetitions in each set smoothly and without pausing. The exertion stage of each repetition should last about half as long as the return stage. Exhale during the exertion stage of each repetition and inhale during the return stroke. Never hold your breath.

Rest for a short period of time after each set:

- Muscle Building—Rest for three minutes after each set.
- Toning—Rest for one minute after each set.
- Weight Loss—Rest for 30 seconds after each set.

STAYING MOTIVATED

For motivation, keep a record of each workout. Write the date, the exercises performed, the resistance used, and the numbers of sets and repetitions completed. Record your weight and key body measurements once a month. To achieve good results, make exercise a regular and enjoyable part of your life.

PART LIST

Model No. 29838.0 R1113A

Key No.	Qty.	Description	Key No.	Qty.	Description
1	1	Base	46	2	V-pulley
2	1	Stabilizer	47	2	Thin Pulley
3	1	Upright	48	9	Thick Pulley
4	1	Top Frame	49	12	M4.2 x 16mm Self-tapping Screw
5	1	Pivot Frame	50	2	Large Cable Trap
6	1	Seat Tube	51	1	Small Cable Trap
7	1	Front Leg	52	8	13mm Spacer
8	1	Leg Lever	53	1	Low Cable
9	1	Right Arm	54	1	Arm Cable
10	1	Left Arm	55	1	High Cable
11	2	Handle	56	22	M10 Locknut
12	1	Square Plate	57	22	M10 Washer
13	1	Curl Post	58	11	M8 Locknut
14	1	Curl Pad	59	5	M8 Washer
15	1	Seat	60	1	Leg Bumper
16	1	Backrest	61	1	Backrest Frame
17	1	Left Shroud	62	6	M6 x 16mm Screw
18	1	Right Shroud	63	1	Double U-bracket
19	4	Shroud Support	64	1	M6 x 32mm Screw
20	2	Carriage Bolt Bushing	65	2	M8 x 22mm Shoulder Bolt
21	2	Weight Guide	66	3	M10 x 51mm Bolt
22	10	Weight	67	2	M10 x 86mm Carriage Bolt
23	1	Weight Selector Cap	68	4	M8 x 65mm Bolt
24	1	Weight Selector	69	3	M4 x 20mm Self-tapping Screw
25	1	Short Knob	70	2	20mm x 40mm Inner Cap
26	1	Weight Pin	71	9	M10 x 67mm Bolt
27	2	Weight Bumper	72	1	M10 x 130mm Bolt
28	4	Small Foam Pad	73	1	Seat Frame
29	1	Pad Tube	74	2	M10 x 25mm Bolt
30	8	50mm Round Inner Cap	75	2	M10 x 63mm Bolt
31	3	50mm Square Inner Cap	76	1	M10 x 64mm Bolt Set
32	1	38mm Square Outer Cap	77	4	M10 x 25mm Button Screw
33	17	M4 Washer	78	4	M4 x 12mm Screw
34	4	Pad Cap	79	1	M10 x 77mm Bolt
35	1	Lat Bar	80	1	Handle Strap
36	2	Handgrip	81	4	M10 x 46mm Bolt
37	3	Cable Clip	82	2	M6 Washer
38	1	Foot Plate	83	1	Chain
39	2	Cable Pivot	84	1	M12 Nut
40	2	Arm Pin	85	1	Large Washer
41	4	Full Guard	86	2	11mm Spacer
42	2	Large Foam Pad	87	4	M8 x 63mm Carriage Bolt
43	8	Half Guard	88	1	Lock
44	4	Arm Bushing	89	1	Lock Pin
45	1	U-bracket	90	2	Shroud Clamp

Key No.	Qty.	Description	Key No.	Qty.	Description
91	2	Long Knob	*	–	User's Manual
92	2	50mm Square Outer Cap	*	–	Exercise Guide
93	2	25mm x 40mm Thick Inner Cap	*	–	Grease Packet
94	2	25mm x 40mm Thin Inner Cap	*	–	Assembly Tool
95	1	M6 x 38mm Screw			

Note: Specifications are subject to change without notice. For information about ordering replacement parts, see the back cover of this manual. *These parts are not illustrated.

EXPLODED DRAWING A

Model No. 29838.0 R1113A

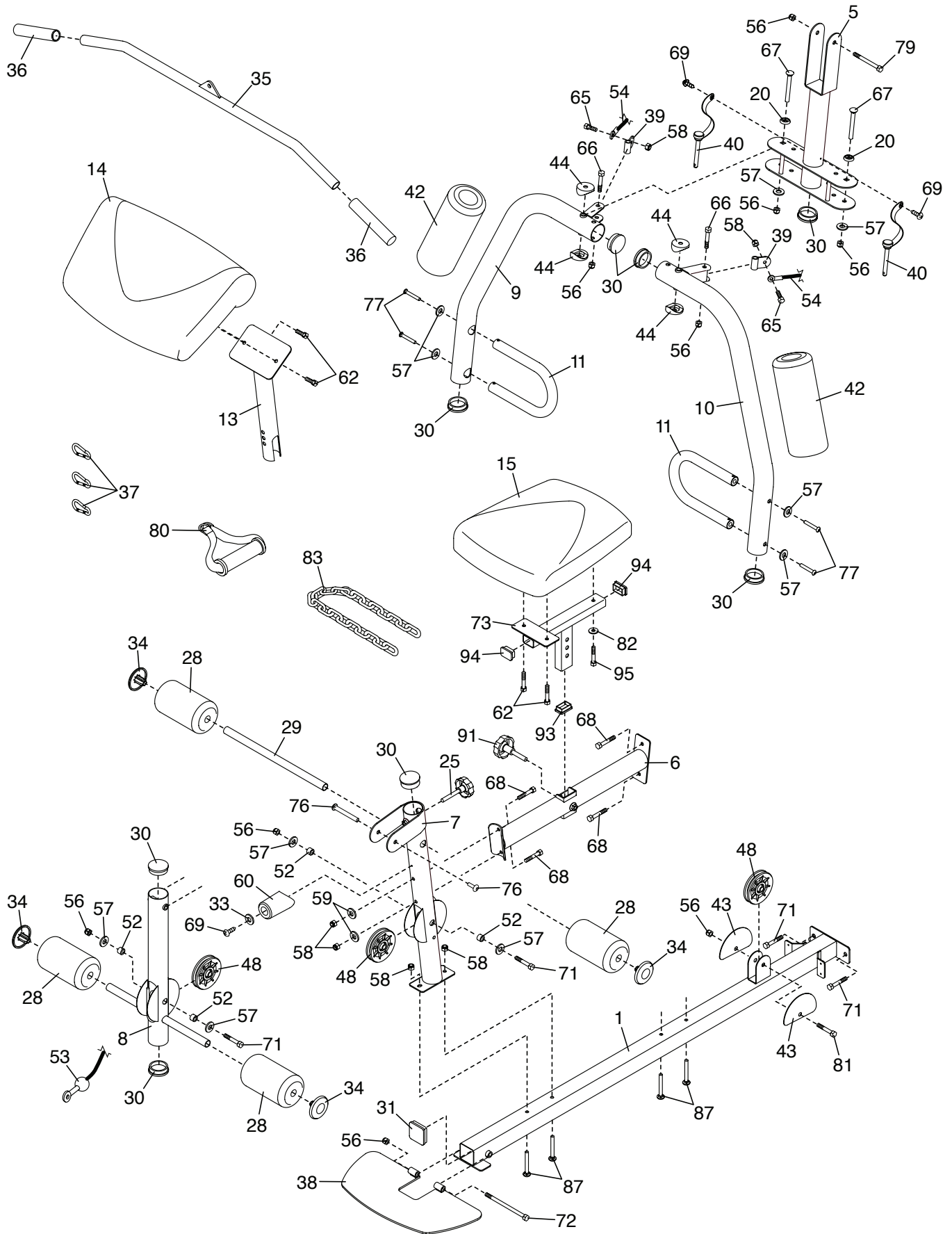

EXPLODED DRAWING B

Model No. 29838.0 R1113A

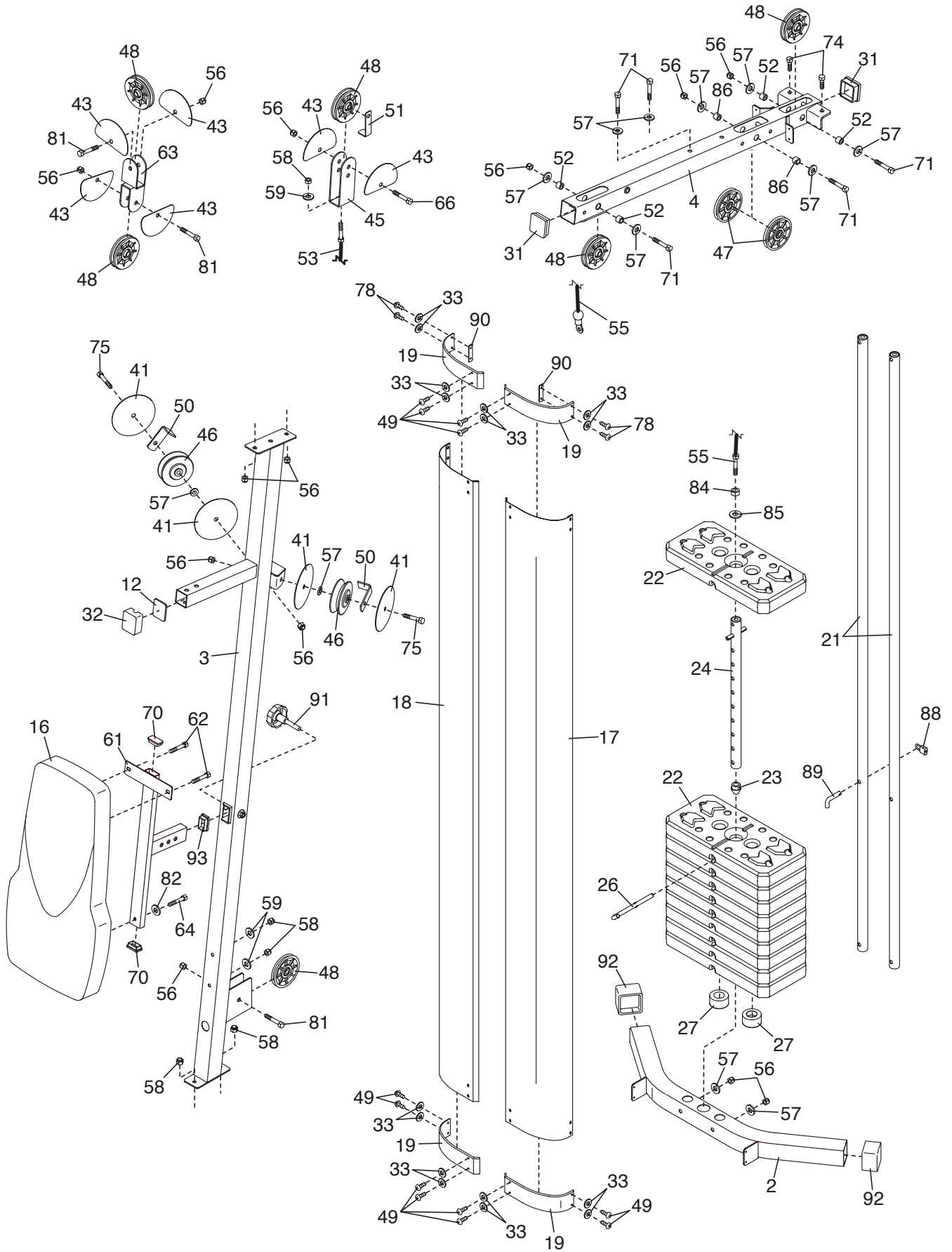

ORDERING REPLACEMENT PARTS

To order replacement parts, please see the front cover of this manual. To help us assist you, be prepared to provide the following information when contacting us:

- the model number and serial number of the product (see the front cover of this manual)
- the name of the product (see the front cover of this manual)
- the key number and description of the replacement part(s) (see the PART LIST and the EXPLODED DRAWING near the end of this manual)

LIMITED WARRANTY

IMPORTANT: To protect your fitness equipment with an extended service plan, see page 4.

ICON of Canada, Inc. (ICON) warrants this product to be free from defects in workmanship and material, under normal use and service conditions. Parts and labor are warranted for ninety (90) days from the date of purchase.

This warranty extends only to the original purchaser (customer). ICON's obligation under this warranty is limited to repairing or replacing, at ICON's option, the product through one of its authorized service centers. All repairs for which warranty claims are made must be preauthorized by ICON. If the product is shipped to a service center, freight charges to and from the service center will be the customer's responsibility. If replacement parts are shipped while the product is under warranty, the customer will be responsible for a minimal handling charge. For in-home service, the customer will be responsible for a minimal trip charge. This warranty does not extend to freight damage to the product. This warranty will automatically be voided if the product is used as a store display model, if all instructions in this manual are not followed, if the product is abused or improperly or abnormally used, or if the product is used for commercial or rental purposes. No other warranty beyond that specifically set forth above is authorized by ICON.

ICON is not responsible or liable for indirect, special, or consequential damages arising out of or in connection with the use or performance of the product; damages with respect to any economic loss, loss of property, loss of revenues or profits, loss of enjoyment or use, or costs of removal or installation; or other consequential damages of any kind. Some provinces do not allow the exclusion or limitation of incidental or consequential damages. Accordingly, the above limitation may not apply to the customer.

The warranty extended hereunder is in lieu of any and all other warranties, and any implied warranties of merchantability or fitness for a particular purpose are limited in their scope and duration to the terms set forth herein. Some provinces do not allow limitations on how long an implied warranty lasts. Accordingly, the above limitation may not apply to the customer.

This warranty provides specific legal rights; the customer may have other rights that vary from province to province.

ICON of Canada, Inc., 900 de l'Industrie, St. Jérôme, QC J7Y 4B8