

Инструкция

Кроссовер Body Craft F450 Cable Crossover

Полезные ссылки:

[Кроссовер Body Craft F450 Cable Crossover - смотреть на сайте](#)

BODYCRAFT

INSTRUCTION MANUAL

MODEL : F450

CABLE CROSSOVER

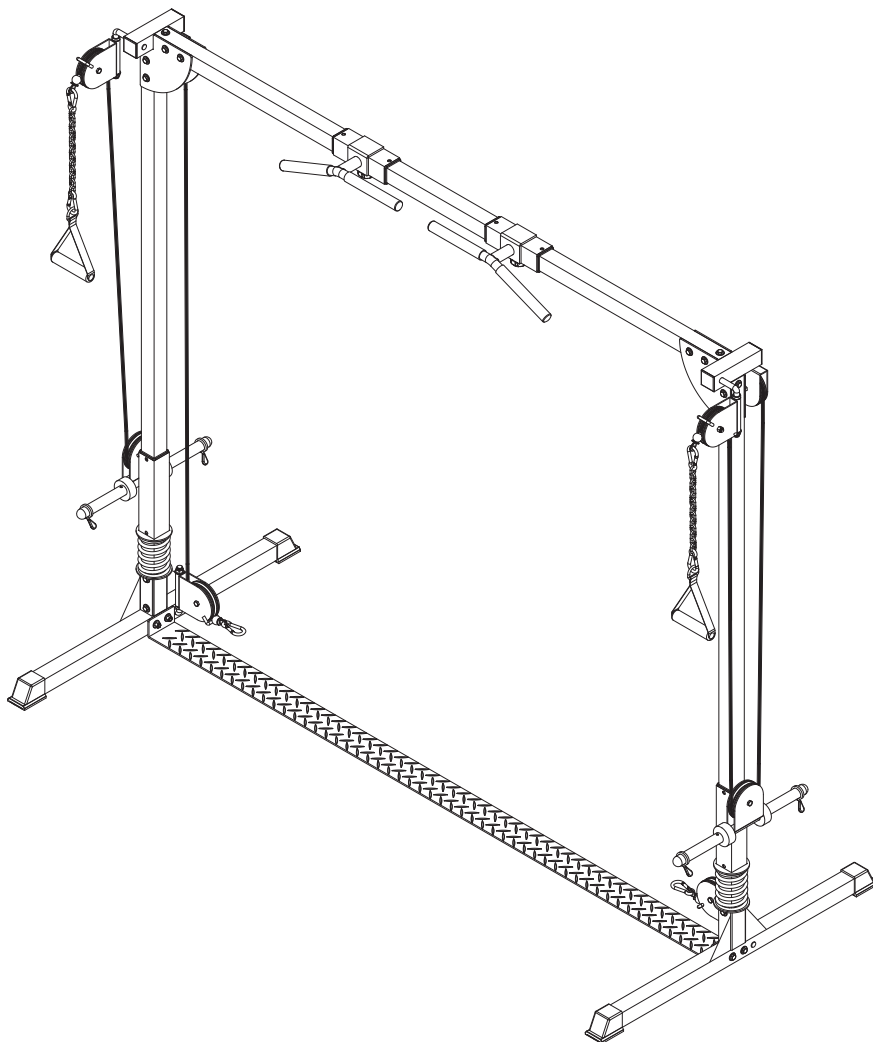

QUESTION?

As a quality home gym supplier we are committed to your complete satisfaction. If you have questions, or find missing or damaged parts, we will guarantee your complete satisfaction through our authorized dealer service centers or our home office customer service department. Please call your local dealer for assistance or BodyCraft at 800-990-5556 (9:00 AM - 5:00 PM). Our trained technicians will provide immediate assistance to you, free of charge.

Bodycraft is a division of Recreation Supply Inc.
P.O. BOX 181
Sunbury, OH 43074

7100

BEFORE YOU BEGIN

Congratulations and thank you for selecting the **BODYCRAFT CABLE CROSSOVER** strength training system. The **BODYCRAFT CABLE CROSSOVER** offers an impressive array of strength training exercises to develop every major muscle group of the body. Whether your goal is cardiovascular fitness, a shapely, toned body or dramatic muscle size and strength, the **BODYCRAFT CABLE CROSSOVER** will help you achieve the specific results you want.

For your safety and benefit, read this manual and the accompanying literature before using the **BODYCRAFT CABLE CROSSOVER**. Keep this manual for future reference.

If you have additional questions, please call your local **BODYCRAFT** dealer or our customer service department at 800-990-5556 Monday through Friday, 9 a.m. until 5 p.m. Eastern Time.

IMPORTANT SAFETY NOTES

There is a risk assumed by individuals who use this type of equipment. Before beginning this or any other exercise program consult your physician. This is especially important for individuals over the age of 35 or persons with pre-existing health problems. Recreation Supply, Inc. assumes no responsibility for personal injury or property damage sustained by or through use of this product.

1. This product must be assembled on a flat, level surface to assure its proper function.
2. Clean pads and frame on a regular basis. We recommend warm, soapy water. Do not use harsh or abrasive chemicals.
3. Inspect and tighten all parts before every use. Replace any worn parts immediately. Failure to do so may result in serious injury.
4. Keep children away from the **BODYCRAFT CABLE CROSSOVER** at all times.
5. Keep your hands away from moving parts other than the designated handles.
6. Exercise with care to avoid injury.
7. If unsure about the proper use of the **BODYCRAFT CABLE CROSSOVER** strength training system call your local **BODYCRAFT** dealer or our customer service department at 800-990-5556.

OVERVIEW

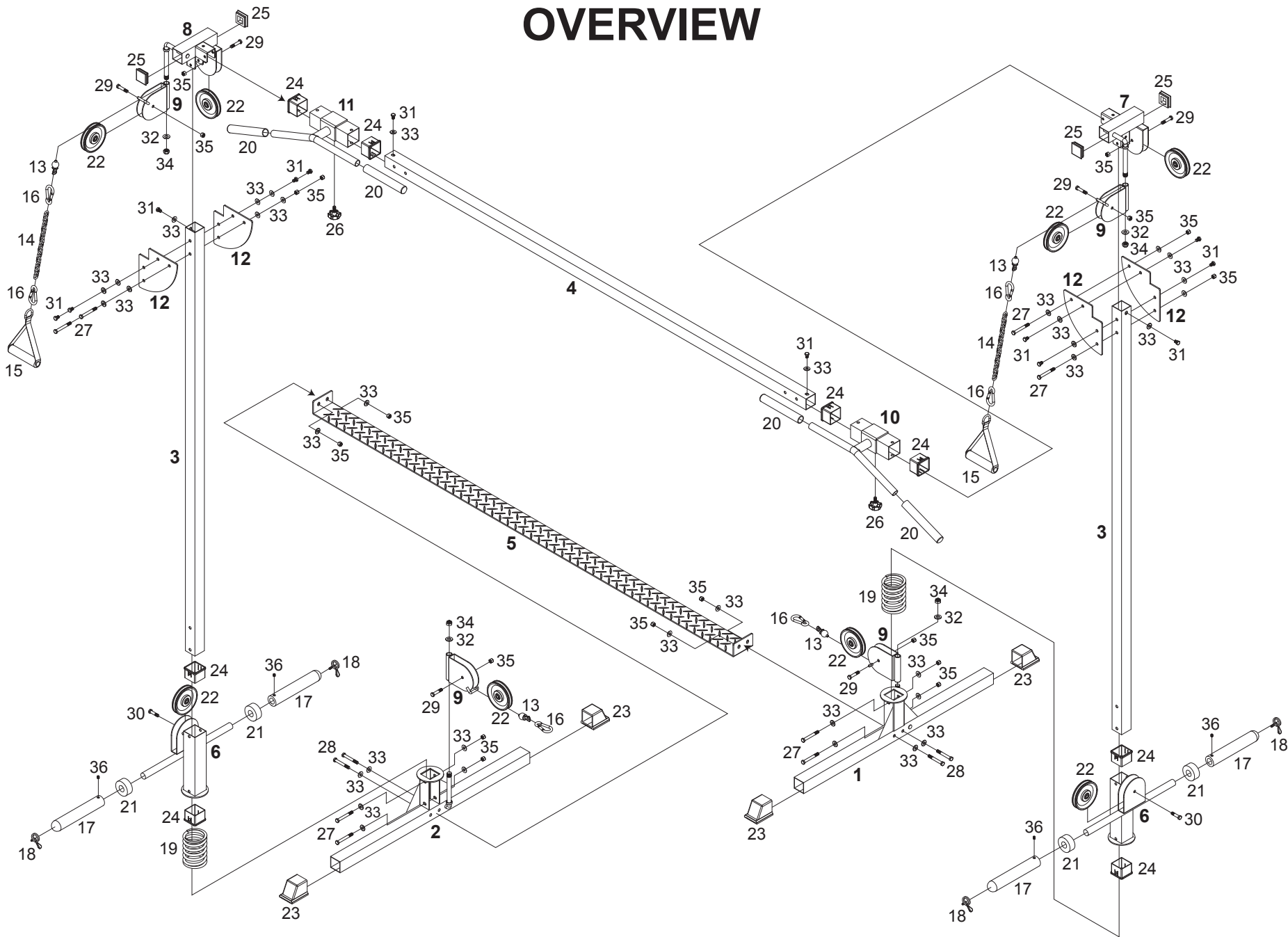

PARTS LIST

NO.	DESCRIPTION	QTY.
1	RIGHT BASE FRAME	1
2	LEFT BASE FRAME	1
3	CHROMED UPRIGHT	2
4	TOP FRAME	1
5	FOOT PLATE	1
6	WEIGHT HOLDER	2
7	RIGHT TOP PULLEY ASSEMBLY	1
8	LEFT TOP PULLEY ASSEMBLY	1
9	SWIVEL PULLEY BRACKET	4
10	RIGHT CHIN UP HANDLE	1
11	LEFT CHIN UP HANDLE	1
12	TRI LINK PLATE	4
13	CABLE	2
14	21 LINK CHAIN	2
15	SINGLE HANDLE	2
16	HOOK	4
17	OLYMPIC SLEEVE	4
18	2" SPRING CLIP	4
19	SPRING COIL	2
20	HAND GRIP	4
21	RUBBER DOUGHNUT	4
22	PULLEY	8
23	50 SQ. END CAP	4
24	50 SQ. BUSHING	8
25	50 SQ. END PLUG	4
26	LOCK KNOB	2
27	3/8" X 3" HEX BOLT	8
28	3/8" X 2-3/4" HEX BOLT	4
29	3/8" X 1-3/4" HEX BOLT	6
30	3/8" X 1-1/2" HEX BOLT	2
31	3/8" X 5/8" HEX BOLT	12
32	1/2" WASHER	4
33	3/8" WASHER	36
34	1/2" NYLON NUT	4
35	3/8" NYLON NUT	18
36	5/16" X 3/8" SET SCREW	4

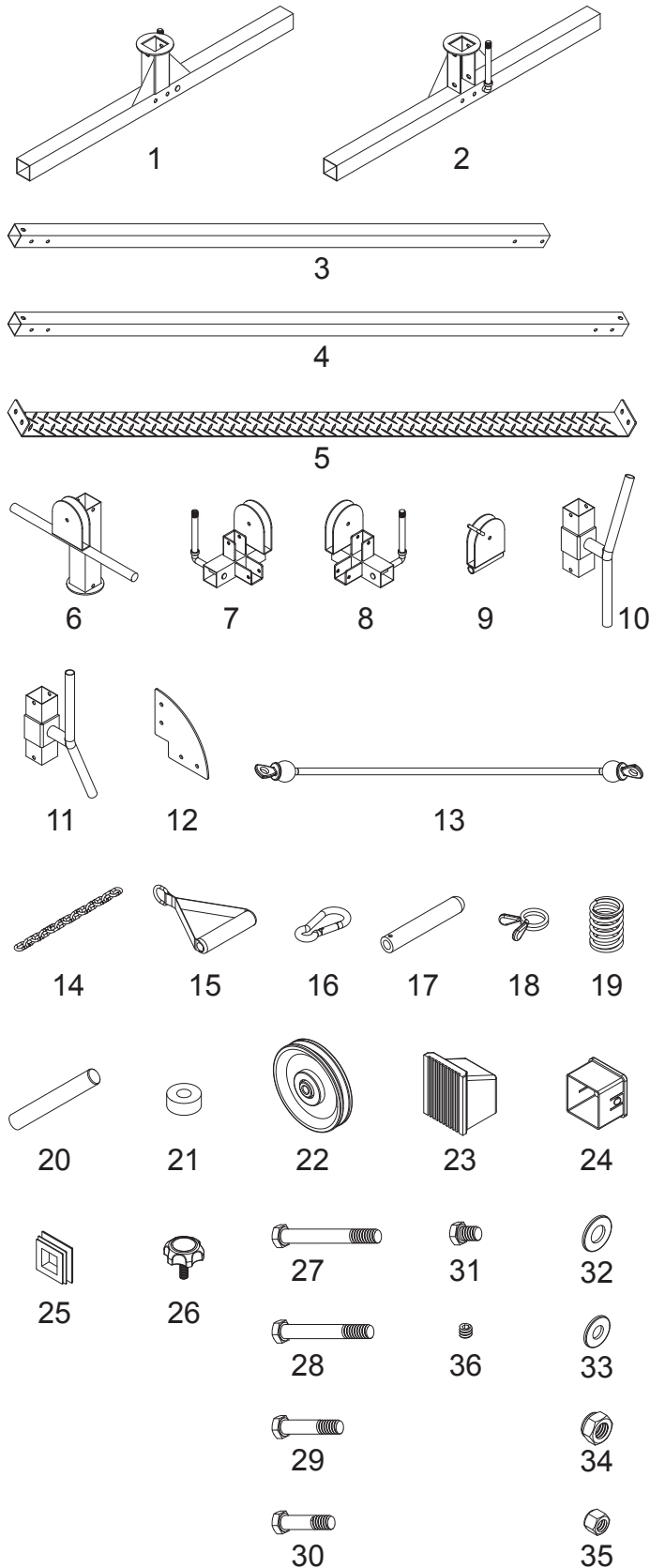

STEP 1 Base Frame Assembly

To ease the assembly process, DO NOT tighten bolts until instructed.

1. Attach a 50 SQ. End Cap (23) to each end of the Right Base (1). Connect Right Base (1) to Foot Plate (5) using two 3/8" X 2-3/4" Hex Bolts (28), four 3/8" Washers (33) and two 3/8" Nylon Nuts (35). Slide Swivel Pulley Bracket (9) onto axle welded on Right Base (1) and secure using a 3/8" Washer (32) and 3/8" Nylon Nut (35) as shown. Repeat same procedures for the Left Base (2).
2. Insert Chromed Upright (3) into block on Right Base (1), aligning two holes in Upright at bottom. Secure with two 3/8" X 3" Hex Bolts (27), four 3/8" Washers (33), and two 3/8" Nylon Nuts (35).
3. Slide Spring Coil (19) and Weight Holder (6) onto Chromed Upright (3). Slide the Rubber Doughnuts (21) and Spring Clip (18) onto each side of the bar on Weight Holders (6) as shown. Weight Holder bar should be located on the outside. Repeat the same procedures for Left side.

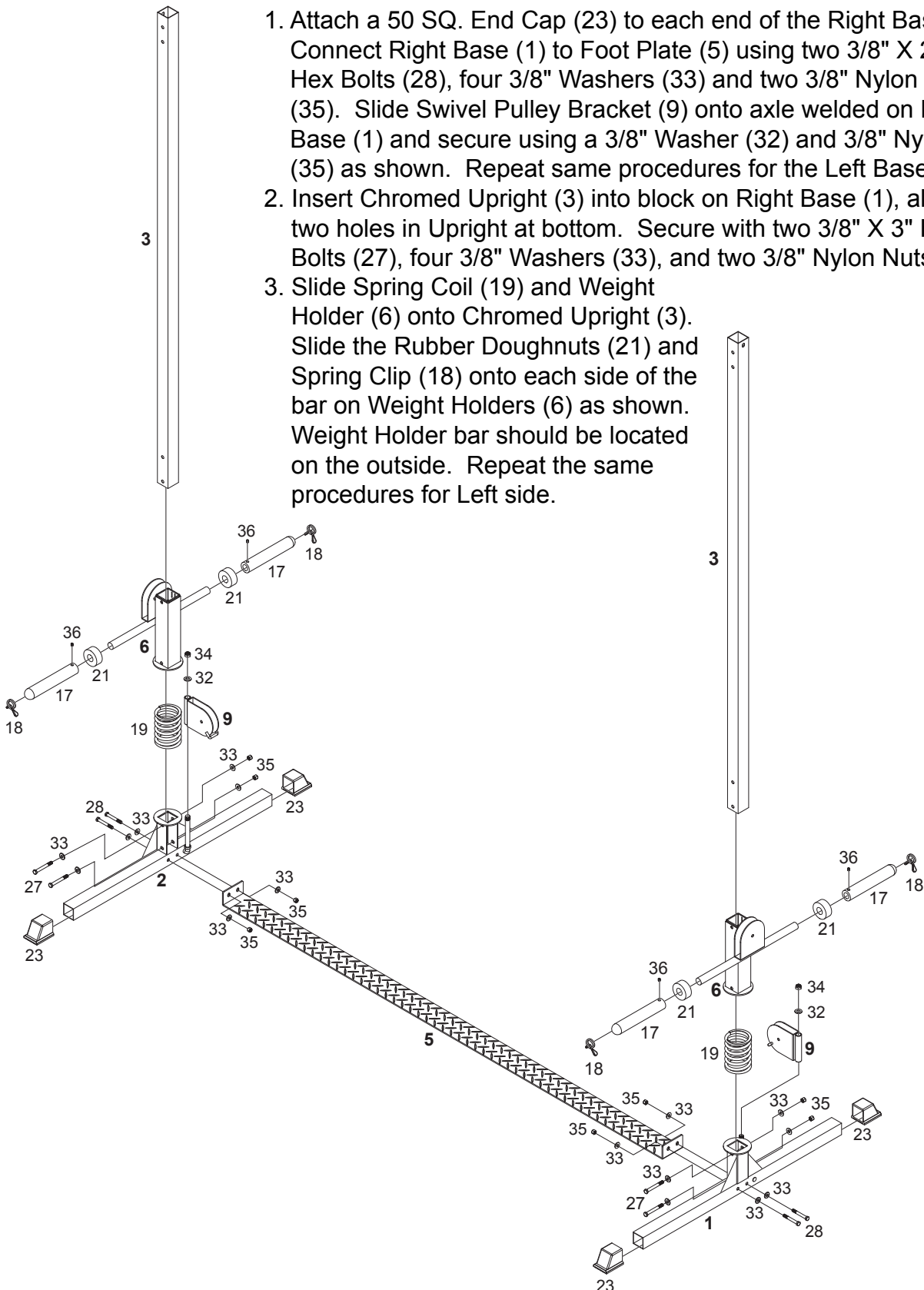

STEP 2 Top Pulley Assembly and Top Frame Assembly

1. Slide Right and Left Chin - Up Handle (10, 11) onto Top Frame (4). The Downward angle on each handle should be toward the outside.
2. Attach Right Top Pulley Assembly (7) to Right Upright (3) using one 3/8" X 5/8" Hex Bolt (31), and one 3/8" Washer (33). Attach Top Frame (4) to Right Top Pulley Assembly (7) using one 3/8" Washer (33), and one 3/8" X 5/8" Hex Bolt (31).
3. Attach two Tri Link Plates to Top Frame (4) and Chromed Upright (3) using two 3/8" X 3" Hex Bolts (27), four 3/8" Washers (33), and two 3/8" Nylon nuts (35).
Repeat same procedures for the Left Top Pulley Assembly.

Tighten all bolts and nuts.

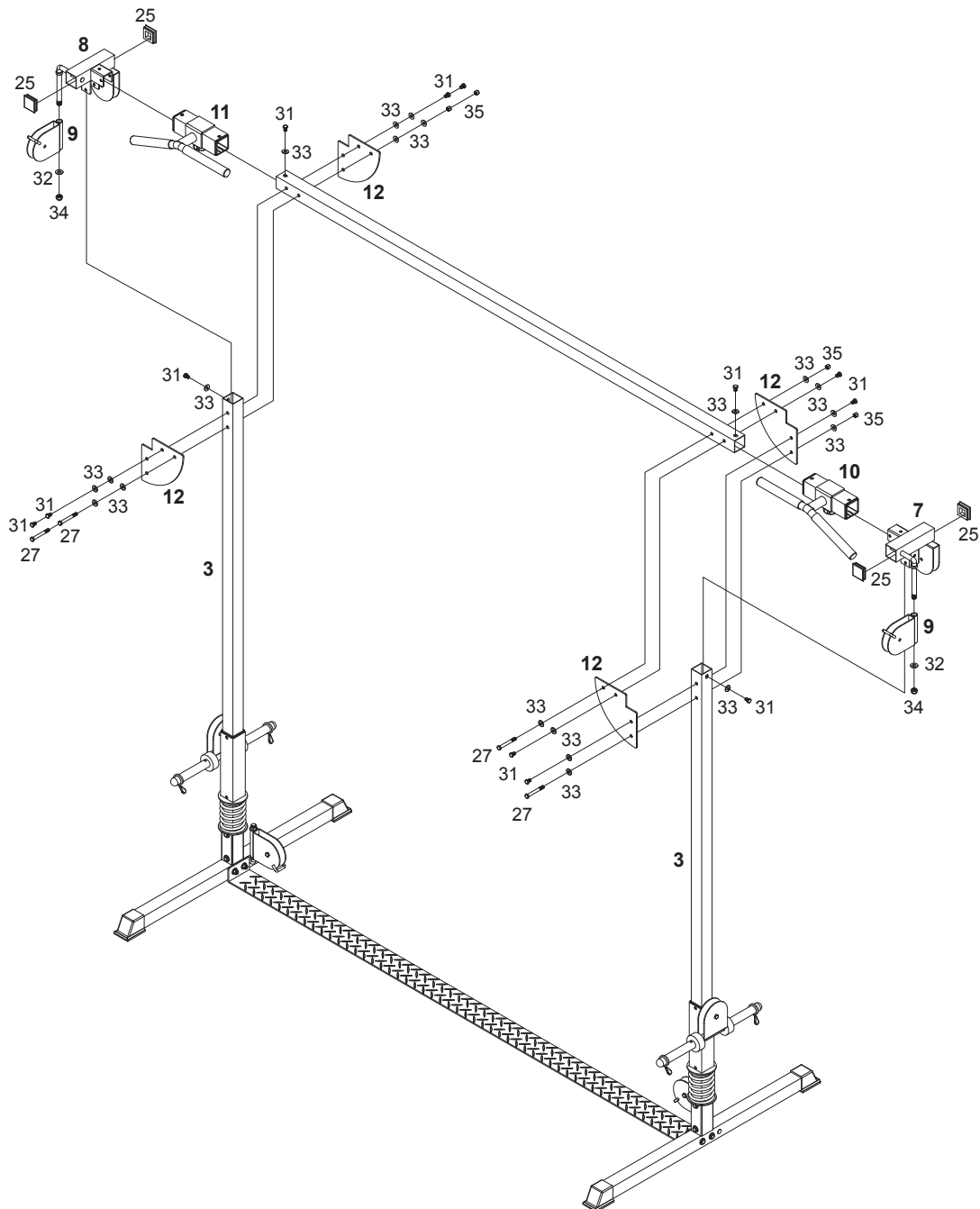

STEP 3 Cable Assembly

Assemble Cable and Pulleys simultaneously.

Route cable from low pulley on right Base Frame (1), up and over top pulley on Right Top Pulley Assembly (7), down to pulley on Weight Holder (6), up and over top pulley on Top Pulley Assembly.

Repeat the same procedures for Left Top Pulley Assembly.

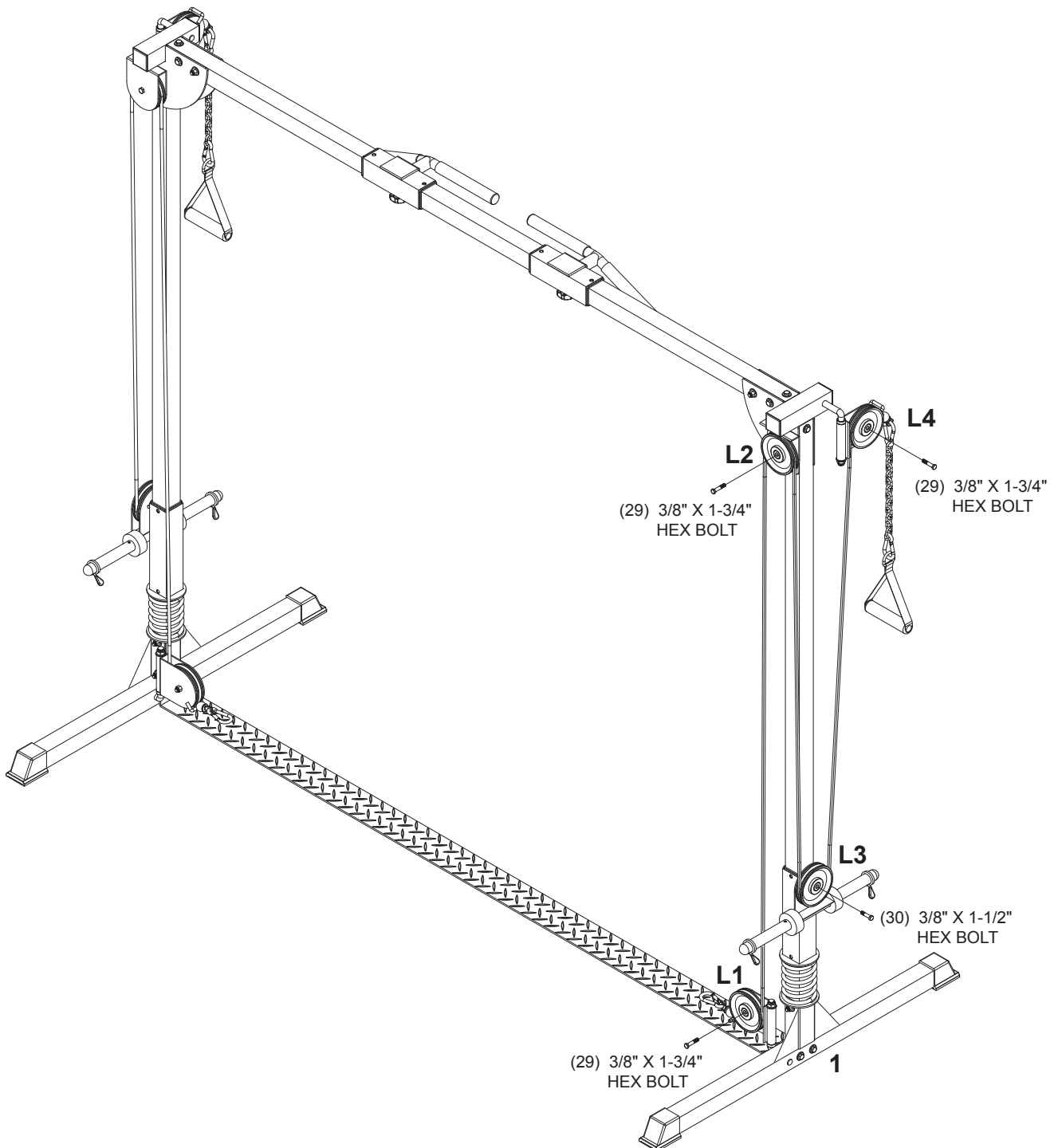

Assembly is complete! Please take the following steps before using the gym:

1. Make certain all bolts are tightened securely.
2. Make certain all cables are seated into all pulley grooves. A cable rubbing against steel will peel the nylon coating, voiding warranty and resulting in a need for replacement.
3. Pre-stretch the cables. Pull on the cables with great force, helping remove any kinks and providing any initial cable stretch.
4. Be aware the cables can loosen and slightly stretch upon initial use.
5. For better performance, apply a household lubricant (such as silicone) to any adjustable areas and to the Chromed Upright (3).
6. Enjoy many years of a Fit Lifestyle.

**Thank you for purchasing the Bodycraft Cable Crossover.
If You have any questions, please call your local BodyCraft dealer
or call our customer service department at 800-990-5556**