

## **Инструкция**

### **Разгибание ног сидя Body Solid PRO CLUB LINE SLE200G-3**

Полезные ссылки:

[Разгибание ног сидя Body Solid PRO CLUB LINE SLE200G-3 - смотреть на сайте](#)

[Разгибание ног сидя Body Solid PRO CLUB LINE SLE200G-3 - читать отзывы](#)

# SLE-200G LEG EXTENSION

THERE IS A RISK ASSUMED BY INDIVIDUALS WHO USE THIS TYPE OF EQUIPMENT. TO MINIMIZE RISK, YOU MUST FOLLOW THESE RULES:

1. Inspect equipment before each workout. Check that all nuts, bolts, screws and pop pins are in place and fully tightened. Also, before use, check cables for signs of wear. Replace all worn parts immediately. Never use machine if any parts are damaged or missing. Failure to follow these rules may result in serious injury.
2. Keep clear of the cables and all moving parts when the machine is in use.
3. Always make sure all Snap Links are closed when doing any cable/pulley exercises.
4. Exercise with care. Perform your exercises at a smooth moderate pace; never perform jerky or uncoordinated movements that may cause injury.
5. It is recommended that you should workout with a training partner.
6. Do not allow children or minors to play on or around this equipment.
7. If unsure of proper use of equipment, call your local Body-Solid distributor or the Body-Solid customer service department at 1-800-556-3113.
8. **WARNING:** Consult your physician before starting your exercise program. For your own safety, do not begin any exercise program without proper instruction.



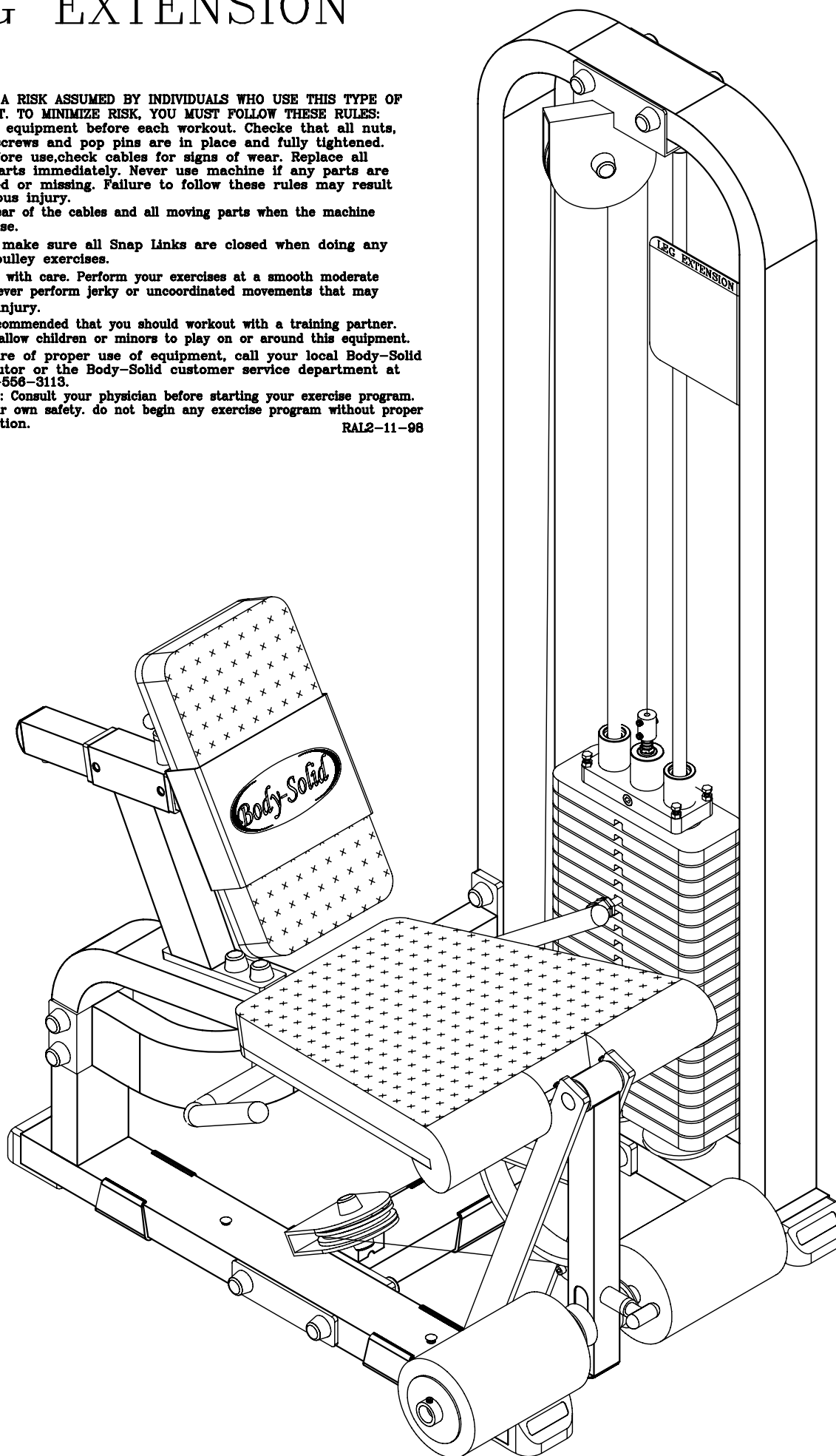







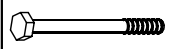

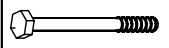
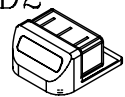
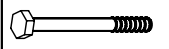

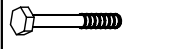

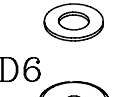





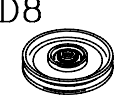



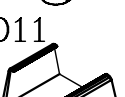
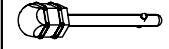
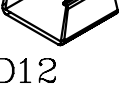

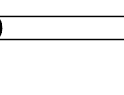
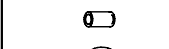
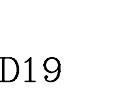

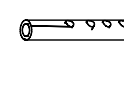
RAL2-11-98

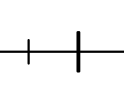

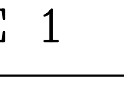
VERSION 200505

# SLE-200G

# HARDWARE ILLUSTRATION SHEET

		Qty.			Qty.
	A1. 1/2"X5 1/2" HEX HEAD BOLT	[6PCS]		D1. 1/2" BOLT CAP	[32PCS]
	A2. 1/2"X5 1/4" HEX HEAD BOLT	[1PCS]		D2. 2"X4" FOOT END CAP (9211-028)	[4PCS]
	A3. 1/2"X5" HEX HEAD BOLT	[4PCS]		D3. 2"X2"X1.8t END CAP (9211-087)	[2PCS]
	A4. 1/2"X3 3/4" HEX HEAD BOLT	[2PCS]		D5. ø2" NYLON WASHER (9214-001)	[2PCS]
	A5. 1/2"X2 1/4" HEX HEAD BOLT	[3PCS]		D6. ø4" RUBBER DONUT (9310-017)	[2PCS]
	A6. 5/16"X3" HEX HEAD BOLT	[1PCS]		D7. ø6" PULLEY (9213-009)	[1PCS]
	A7. 5/16"X1 1/4" HEX HEAD BOLT	[6PCS]		D8. ø4 1/2" PULLEY (9213-010)	[2PCS]
	A8. 7/16"X1 1/2" ROUND BOLT	[1PCS]		D10. ø3/4" SHAFT COLLAR (9211-046)	[2PCS]
	A9. 5/16"X3/8" SET SCREW	[3PCS]		D11. 2"X4" RUBBER DOUNT (9212-009)	[3PCS]
	A10. 5/8" ROUND BOLT	[1PCS]		D12. ø1"X10" RUBBER GRIP (9310-029)	[2PCS]
	A11. 10LB BALL PIN	[1PCS]		D14. 60X50 NYLON BUSHING (9211-033)	[2PCS]
	A12. 5/16"X1 1/2" ROUND BOLT	[1PCS]		D16. ø2 1/2" RUBBER DONUT (9310-014)	[2PCS]
	A13. 1/2"X22 SLEEVE	[1PCS]		D17. ø150X225 FOAM ROLLER (9161-015)	[2PCS]
	B1. 1/2" NYLON LOCK NUT	[16PCS]		D18. CHROME TOP PLATE (8400-002)	[1PCS]
	B2. 5/8" LOCK NUT	[1PCS]		D19. WEIGHT SELECTOR BAR (8220-060)	[1PCS]
	B3. 5/16" NYLON LOCK NUT	[1PCS]		D20. STEEL CABLE	[1PCS]
	C1. 1/2" ROUND END CAP WASHER	[32PCS]		D21. ø3/4"X8L STEEL BUSHING (8110-014)	[2PCS]
	C2. ø1" CHROME WASHER	[2PCS]		D22. ø5/8" ROUND END CAP (9211-015)	[4PCS]
	C3. 5/16" (I.D)WASHER	[7PCS]		D23. ø1" SHAFT COLLAR (8130-024)	[2PCS]
	C4. 5/16" SPRING WASHER	[7PCS]		D24. ø3" NYLON WASHER (9214-008)	[4PCS]
	C5. 5/8" SPRING WASHER	[1PCS]			

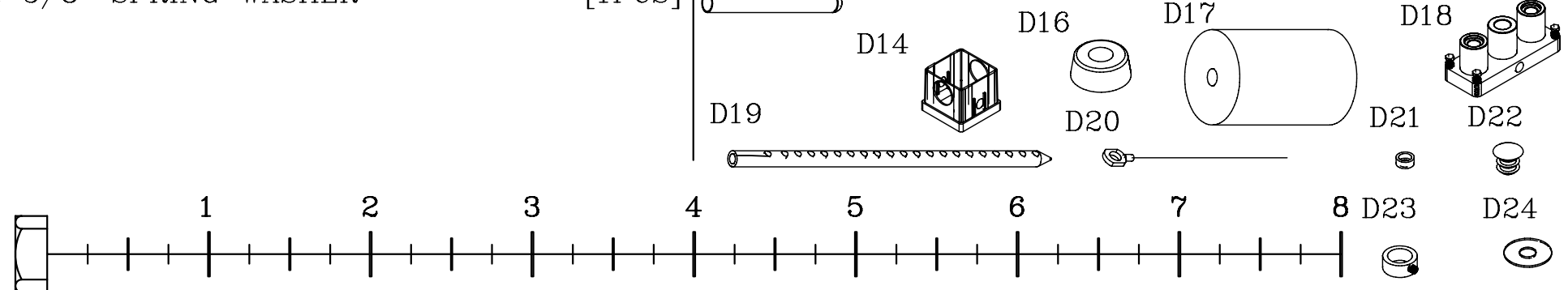

A [1PCS] WEIGHT STACK FRAME

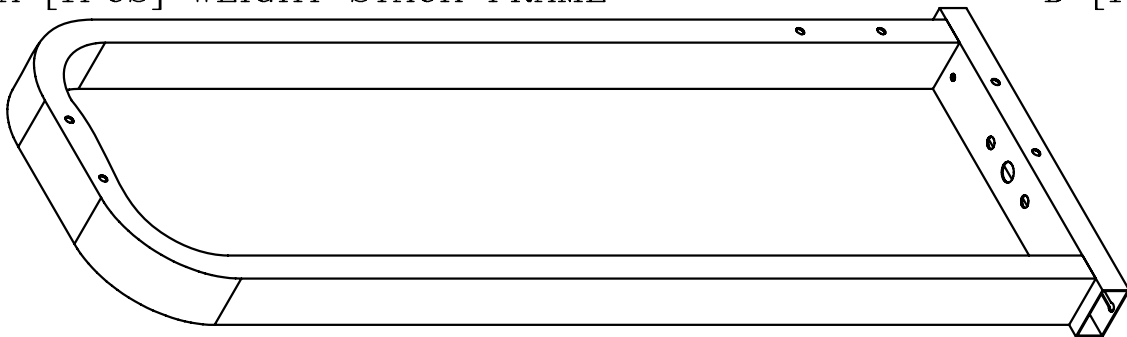

D [1PCS] MAIN BODY FRAME

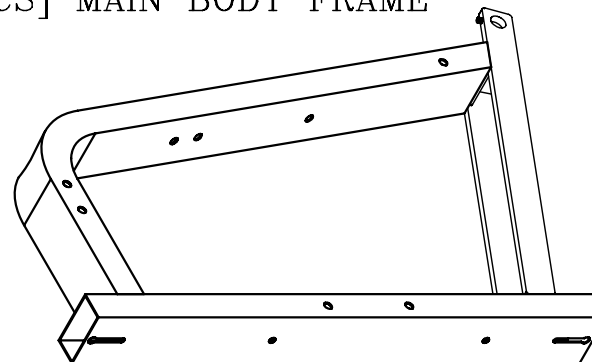

I [1PCS] ROLLER BAR FRAME



H [1PCS] TOP PULLEY FRAME

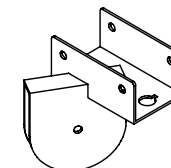

B [1PCS] BOTTOM PULLEY FRAME

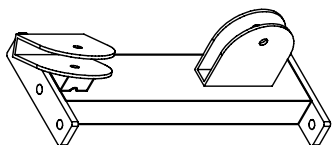

F [1PCS] ADJUSTABLE BACK SUPPORT

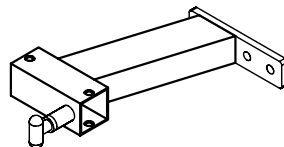

J [1PCS] HANDLE BAR

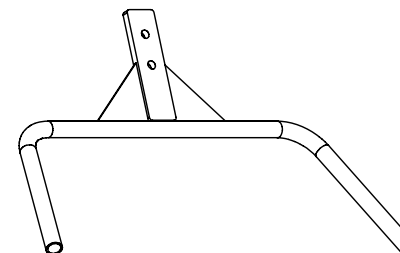

C [1PCS] MIDDLE SUPPORT FRAME

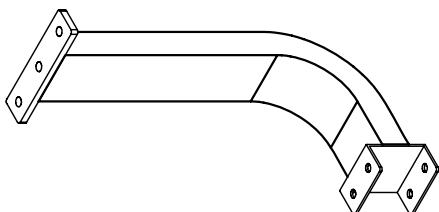

G [1PCS] BACK PAD FRAME

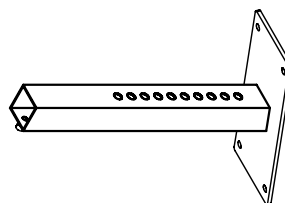

E [1PCS] LEG EXTENSION FRAME

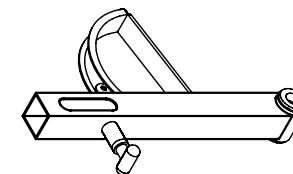

K [2PCS] CHROME GUIDE ROD

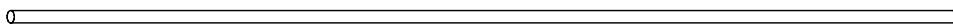

O [1PCS] SEAT PAD

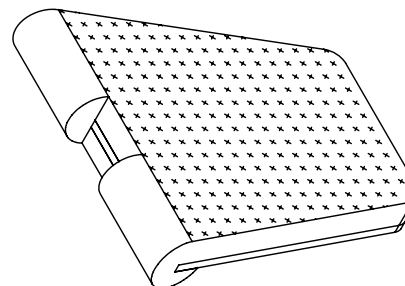

P [1PCS] BACK PAD

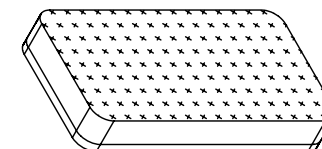

L-1 [1PCS] FOOT ROLLER BAR  
(ø1"X610L)

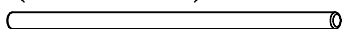

M [3PCS] 2"X8" PLATE



N [2PCS] SEAT BRACKET



Q [1PCS] BACK PAD RUBBER

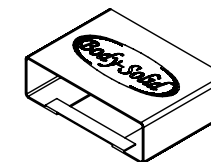



# SLE-200G LEG EXTENSION ASSEMBLY STEPS

## STEP-1

**NOTE: DO NOT TIGHTEN NUTS AND BOLTS SECURELY UNTIL YOU HAVE COMPLETED ALL ASSEMBLY STEPS.**

- Attach **A** Weight Stack Frame and **D** Main Body Frame to **B** Bottom Pulley Frame.
- Attach **C** Middle Support Frame to **A** Weight Stack Frame and **D** Main Body Frame.
- Attach **E** Leg Extension Frame to **D** Main Body Frame.
- Attach **F** Adjustable Back Support and **J** Handle Bar to **D** Main Body Frame.

## STEP-2

- Attach **N** Seat Brackets to **D** Main Body Frame.
- Attach **O** Seat Pad to **D** Main Body Frame and **N** Seat Brackets.
- Attach **P** Back Pad to **D** Main Body Frame.
- Slide **G** Back Pad Frame into **F** Adjustable Back Support.

**CAUTION: DO NOT OVERTIGHTEN PAD BOLTS.  
OVERTIGHTENING WILL STRIP  
T-NUTS IN THE WOOD.**

## STEP-3

- Attach **K** Chrome Guide Rods and **D6** Rubber Donuts to **A** Weight Stack Frame
- Slide Weight Stack and **D18** Chrome Top Plate onto **K** Chrome Guide Rods.
- Attach **H** Top Pulley Frame to **A** Weight Stack Frame and attach **D10** Shaft Collar.
- Slide **I** Roller Bar Frame **E** Leg Extension Frame.
- Slide **L** Foot Roller Bar into **I** Roller Bar Frame
- Attach **D17** Foam Rollers.

## STEP-4

- Attach Pulleys and Cables as shown.
- Attach End Caps and Grips.
- TIGHTEN ALL NUTS AND BOLTS SECURELY.
- Attach Bolt Caps.

### SAFETY RULES

1. Periodically check that all nuts, bolts and screws are fully tightened on your LEG EXTENSION MACHINE.
2. Exercise with care. Perform your exercises at a smooth moderate pace; never perform jerky or uncoordinated movements that may cause injury.
3. It is recommended that you should workout with a training partner.
4. **Warning:** CONSULT YOUR PHYSICIAN BEFORE STARTING YOUR EXERCISE PROGRAM. IT IS ADVISABLE TO HAVE A PHYSICAL EXAMINATION BEFORE YOU ENTER ANY EXERCISE PROGRAM. FOR YOUR OWN SAFETY, DO NOT BEGIN ANY EXERCISE WITHOUT PROPER INSTRUCTION.

# SLE-200G LEG EXTENSION

