

Инструкция

Разгибание ног сидя Bronze Gym MV-014

Полезные ссылки:

[Разгибание ног сидя Bronze Gym MV-014 - смотреть на сайте](#)

[Разгибание ног сидя Bronze Gym MV-014 - читать отзывы](#)

LEG EXTENSION

MV-014



USER MANUAL

CONTENTS

| | |
|-----------------------------|----------|
| 1.INTRODUCTION..... | 1 |
| 2. FEATURE..... | 1 |
| 3. WARNING..... | 1, 2 |
| 4. GUIDANCE..... | 2, 3 |
| 5. NOTICE..... | 3 |
| 6. MAINTENANCE..... | 3 |
| 7 . ASSEMBLY..... | 4 |
| 8. CABLE..... | 5 |
| 9. EXPLODED VIEW..... | 6 |
| 10. TOOLS FOR ASSEMBLY..... | 7 |
| 11. STEPS OF ASSEMBLY..... | 7,8,9,10 |

1. INTRODUCTION

Thank you for purchasing this unit.

For your health and safety, please make a reasonable training program with suitable weight stack and correct postures under the coach's guidance before starting the workout. Kindly please read this manual carefully before using the unit.

Please fill out the maintenance form carefully and keep it with receipt for after-sale service.

2. FEATURE

- a. Reasonable structure, simplified design. High-quality square steel tube applied for the main parts, safe and durable.
- b. Ergonomic design, well-distributed quality steel cables, comfortable and safe.
- c. Special cover to protect the user from the weight stack.
- d. Fine bearing at jointings for smooth movements
- e. Proper handles design, comfortable and easy use.

3. WARNING

1. This training equipment is only intended for use in training areas of organizations such as sport associations, educational establishment, hotels, clubs and studios, where access and control is specifically regulated by the owner (person who has the legal responsibility).
2. The training equipment shall only be used in areas where access control is specifically regulated by the owner; the extent of control depends on the users. e.g. degree of reliability, age, experience, etc.
3. The training equipment shall only be used in supervised areas.
4. Always keep unsupervised children and disabled away from the equipment.
5. Injury to health may result from incorrect or excessive training, please consult the coach to choose correct exercise method and proper burden.
6. Please adjust load and equipment further (e.g. seat adjustment) before using.
7. Please check if the bolt and handrail are out of work before starting to use it.
8. When weight stacks, booms and other parts of this equipment are blocked, must handle with other people's assistance, in case that the weight stacks may suddenly drop and cause accident.
9. Adjust the length of the steel cable properly and never make the steel wire rope twist. After using the machine for a period, the owner shall check the steel cable to make sure no unusual phenomena in connecting. When meet any problems, please consult the professional maintenance personal at once.
10. Do not suddenly drop the weight stack. In order to avoid destroying other weight stacks, please raise it when the weight stacks nearly collide.
11. While using, forbid hands stretching into the weight stacks or the relative

motion parts, so as not to injure the finger.

12. Never allow person with heart disease and children under 12 to use machine

13. The training equipment is in compliance with EN 957-2 class S(S=studio);

14. The max training weight is 150kgs (330pound). The max user's body weight is 150kg (330pound).

15. The machine should be located stably. A space of 2000mm*2000mm should be around the machine.

16.The scope of products: Primary use in professional fitness club.The second is the residence community, gym of some company

17. If you feel swirl, surfeit and other discomfort sense, Please stop exercising and go for doctor.

18. The equipment should be installed on stable even surface.

19. The machine shall only be used indoor and be avoid of moisture.

20. Wear right shoes and coat

21. Warm up before exercising

22. Don't use the equipment to do the impossible function

23. Please exercise under instruction by professional coach.

24. Inspect if the equipment is fastness before using

25. Any of the adjustment devices that could interfere with the user movement should not be left projecting

4. GUIDANCE



MV-014 LEG EXTENSION

EXERCISE PART: Brachial quadriceps

Dimension: 1130mm(L)*1470mm(W)*1600 mm(H)

N.W: 186.5kg

Usage Guidance:

1 Read all caution Warning Labels before using this equipment.

- 2 Adjust the seat then put your back firmly against back pad.
- 3 Insert pin into weight stack at desired resistance level.
- 4 Arm natural contraction, both hands holding the whip handle.
- 5 Arm extension forward, slowly forward push movable arm. Until completely stretched arm.
- 6 Keep the status for a moment, then slowly return to the start position and repeat the movement.

5. NOTICE

1. Warm-up.

It takes 5-10 minutes to warm-up before starting exercise, for instance mark time, free-standing exercises etc., in order to move each joint muscle, so as not to injure the joint muscle while exercising.

2. Diet

Eat some more protein, vegetables, and fruit. Begin to do exercises until 40 minutes after a meal. Taking food until half an hour after doing exercises and drinks little water while doing exercise.

3. Breath

Breathe in while exerting oneself, exhale while relaxing. To coordinate breathe with movement.

4. Frequency

It needs to take a rest over 48 hours before exercising the same muscle.

5. Burden

Exerciser should choose suitable weight according to one's own actual conditions, make sure not to be overweight, so as not to cause the muscle to draw wounded. Exercises should according to the progressive principle; it is normal to feel ache while exercise for the first time.

6. MAINTENANCE

1. For safety use of machines, regularly maintenance must be implemented. Especially for the attrition parts, such as cable, pulley block and connection parts.
2. Special attention should be paid to easy worn parts.
3. Replace the damaged components immediately and stop using the machine until it is fixed.
4. Maintenance should be made as following instruction.

| Maintenance | Daily | Weekly | 3 Month |
|-------------------------------------------------------|-------|--------|---------|
| Check the connection parts, pulley and balance weight | | | |
| Clean cushion and shield | √ | | |
| Lubricating needed parts | | | √ |
| Check the whether the screws are loosen or not | | √ | |
| Lubrication: bearing | | | √ |

7. ASSEMBLY

All the content of user's manual is to assure the strength training machine can be

installed more easily

Reading the details and instructions before installing:

1. Because the size and weight of equipment is so large, Please choose the installed place near the desired station and assured there is enough space to exercise
2. All parts can be put on the clear area, then backout the wrapper. And the wrapper can't be through away before installation finished.
3. Screw the bolt tightly except the additional instruction
4. All parts must be installed according the illustration indication.
5. Installation work can be finished by two men
6. Identify all parts by part identify chart
7. If there are difficulty in inserting the weight stack plug while assembling, please adjust the four adjusting top jackscrew on the first weight stack.

8. CABLE

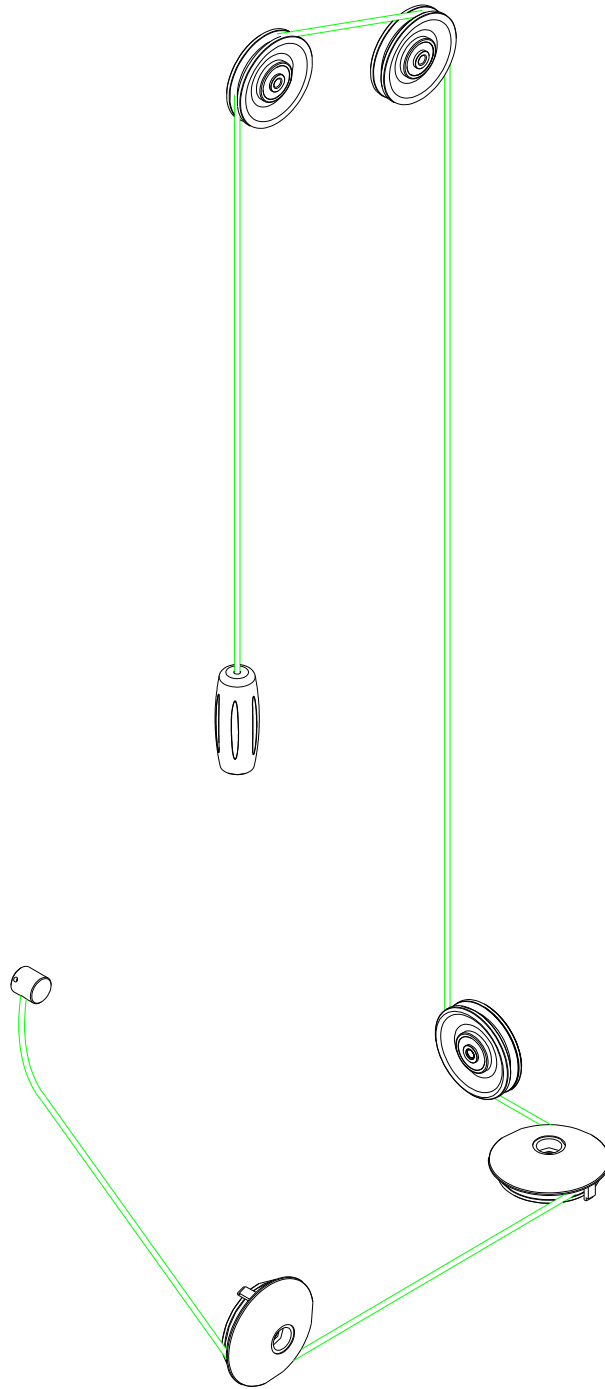

9. EXPLODED VIEW

1. M6 Hex spanner
2. M8 Hex spanner
3. Cross Screwdriver
4. 17-19 Spanner

11. STEPS OF ASSEMBLY

Step 1

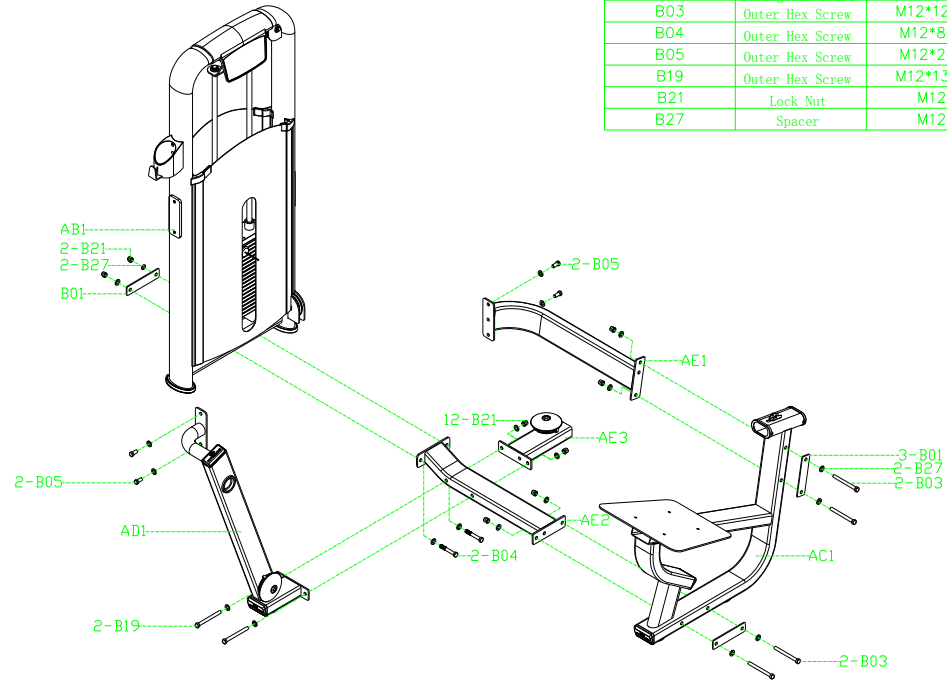

| P/N | Name | Spec | Qty |
|-----|----------------------------------------|-----------|-----|
| AB1 | Frame Cover Assembly | | 1 |
| AC1 | Main Frame Assembly | | 1 |
| AD1 | Exercise Arm Support Group | | 1 |
| AE1 | Back Connecting Support Welding Group | | 1 |
| AE2 | Lower Connecting Support Welding Group | | 1 |
| AE3 | Pulley Fixed Group | | 1 |
| B01 | Connection Strengthen Board | 42*180*T4 | 3 |
| B03 | Outer Hex Screw | M12*125L | 4 |
| B04 | Outer Hex Screw | M12*80L | 2 |
| B05 | Outer Hex Screw | M12*20L | 4 |
| B19 | Outer Hex Screw | M12*130L | 2 |
| B21 | Lock Nut | M12 | 8 |
| B27 | Spacer | M12 | 20 |

Step 2

| P/N | Name | Spec | Qty |
|-----|--------------------------|---------|-----|
| AD2 | Rope plate group | | 1 |
| AD5 | adjustable leg pad group | | 1 |
| B11 | Cup Head Inner Hex Screw | M8*15L | 2 |
| B32 | Deep hook ball bearing | 6005 | 2 |
| B53 | Deep hook ball bearing | 6006 | 2 |
| D29 | Arm Axis | ∅30x166 | 1 |
| M04 | ∅ 60 bearing Cover | ∅60*12 | 2 |

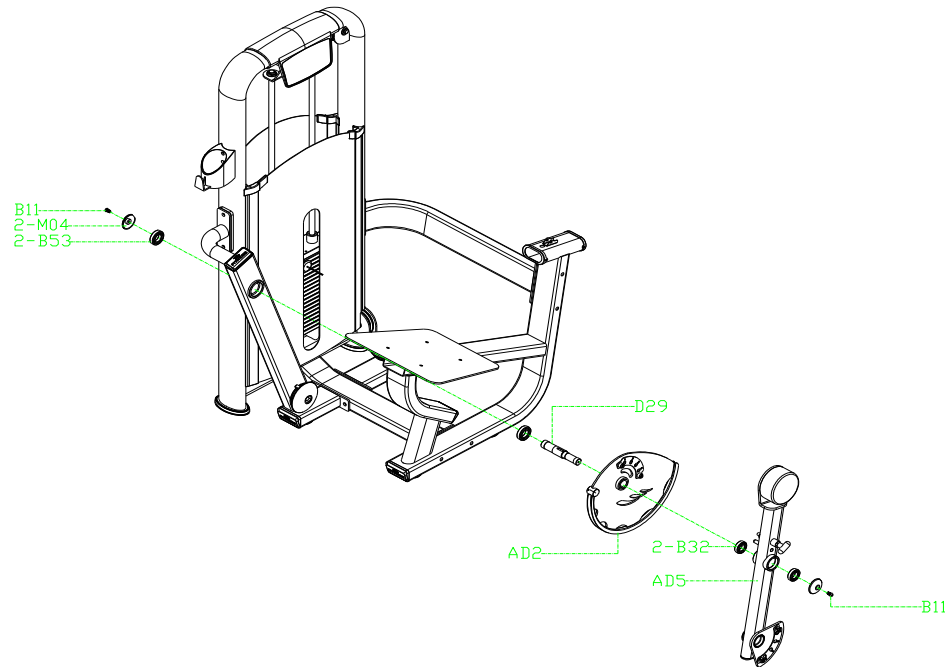

Step 3

| P/N | Name | Spec | Qty | P/N | Name | Spec | Qty |
|-----|-----------------------|------------|-----|-----|--------------------------|----------|-----|
| H01 | Ajustable pull spring | ∅12*∅15*12 | 1 | AD3 | Rotary Assembly | | 1 |
| D25 | Knob Limit parts | ∅18*12.5 | 1 | AD6 | Adjusting Asembly | | 1 |
| M36 | Foam retainer ring | ∅52*∅92*T7 | 2 | AF1 | Left Handle Group | | 1 |
| M37 | Foam Cover | ∅110*T18 | 1 | AF2 | Right Handle Group | | 1 |
| M25 | ∅50 decorate cap | ∅53*13 | 2 | P01 | Foam tube parts | ∅125*495 | 1 |
| M46 | Ajustable Knob Cover | ∅43*37 | 1 | B09 | Cup Head Inner Hex Screw | M8*25L | 2 |
| M47 | Ajustable Knob Cover | ∅36*22 | 1 | B19 | Outer Hex Screw | M12*130L | 2 |
| | | | | B21 | Lock Nut | M12 | 2 |
| | | | | B38 | Deep hook ball bearing | 6004 | 2 |
| | | | | B58 | Hollow screw | M16*24L | 1 |

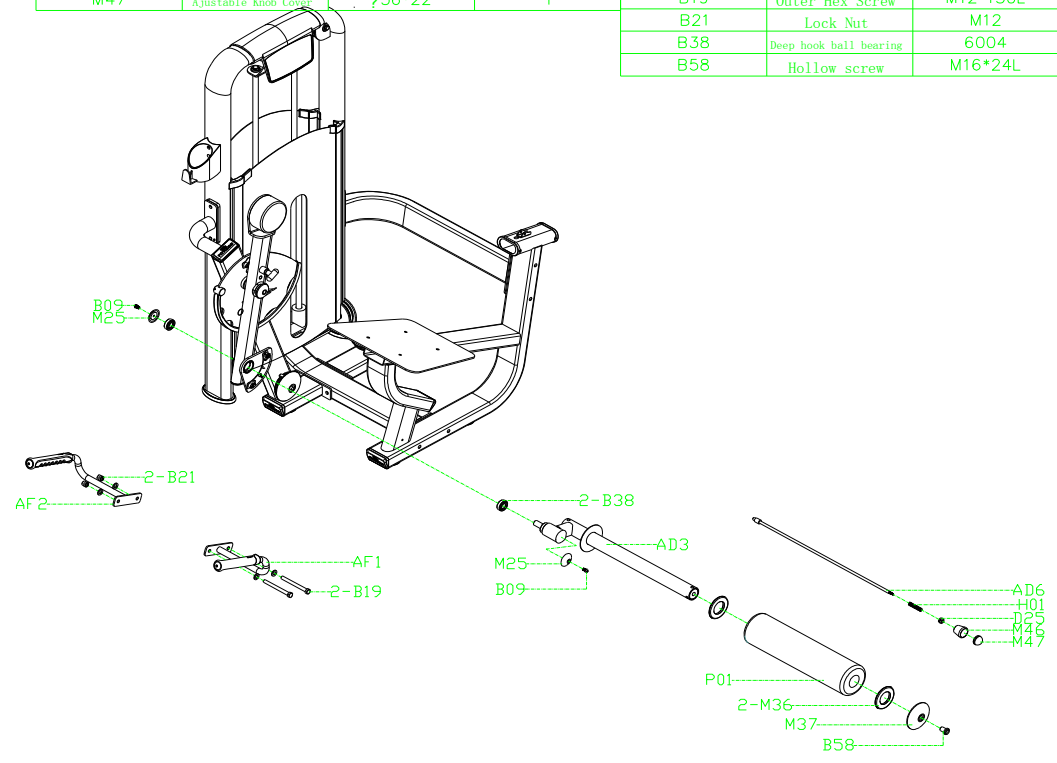

Step 4

| P/N | Name | Spec | Qty |
|-----|--------------------------|------------|-----|
| AG1 | Back Pad Group | | 1 |
| J04 | Back Pad | 250*450*62 | 1 |
| J12 | Cushion | 580*490*95 | 1 |
| B09 | Cup Head Inner Hex Screw | M8*25L | 8 |
| B29 | Spacer | M8 | 8 |

