

Инструкция

Тренажер для подтягиваний и отжиманий Гравитрон Impulse IF8120-250

Полезные ссылки:

[Тренажер для подтягиваний и отжиманий Гравитрон Impulse IF8120-250 - смотреть на сайте](#)

[Тренажер для подтягиваний и отжиманий Гравитрон Impulse IF8120-250 - читать отзывы](#)

IF8 120

Weight Assisted Chin/Dip Combo

OWNER'S MANUAL

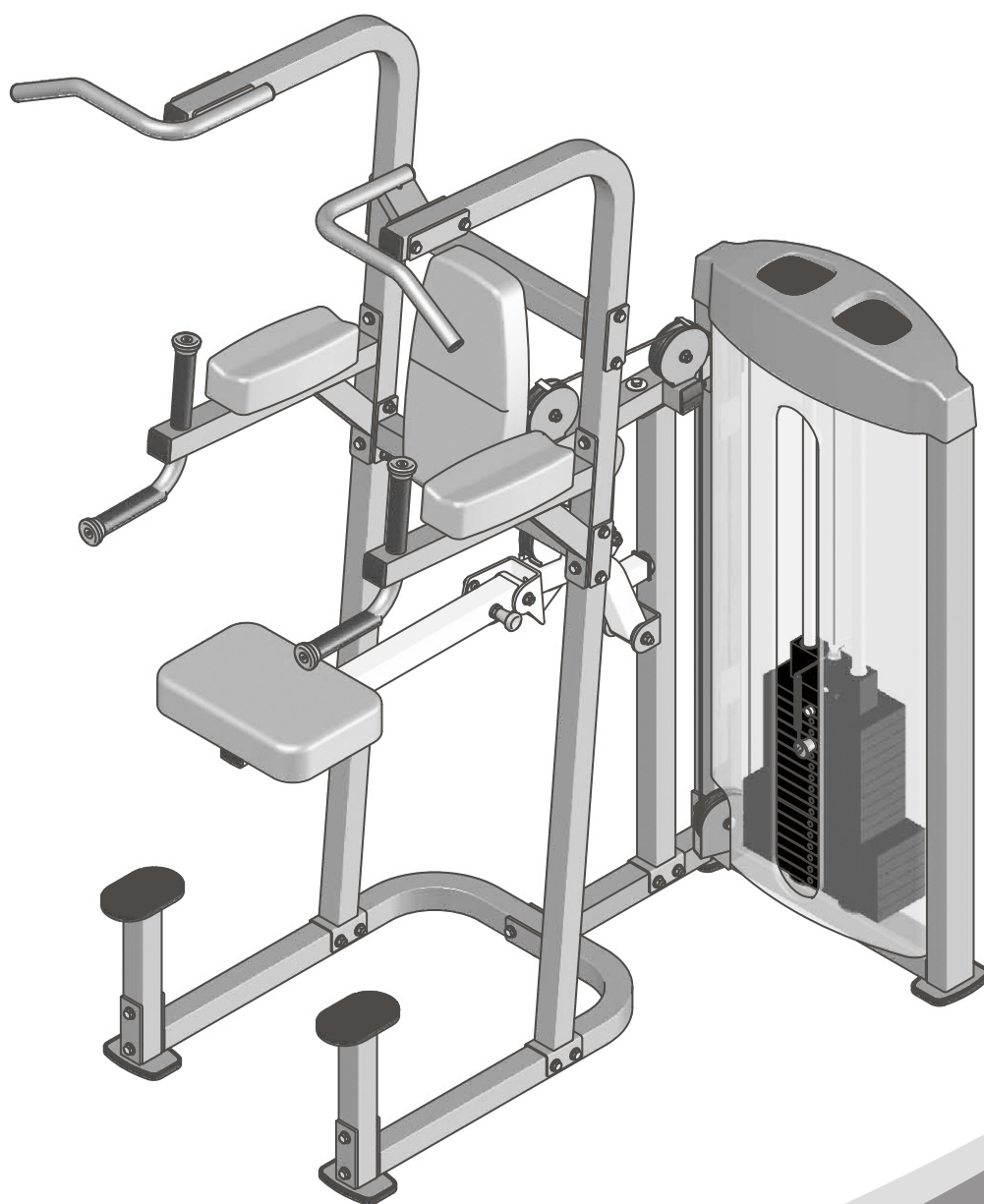

! CAUTION

Read all precautions
and instructions in this manual
before using this equipment

! CAUTION

Read all precautions and instructions in this manual before using this equipment.

Table Of Contents

Important Safety Instructions-----	3
Instructions-----	4
Parts List-----	5
Exploded View -----	8
Measurement Guide-----	9
Assembly Instructions-----	10
Assembly-----	11
Exercise Instructions-----	21
Specifications-----	21
Maintenance Schedule-----	22
General Maintenance Information-----	23
Weight Training Tips-----	24

Important Safety Instructions

Before beginning any fitness program, you should obtain a complete physical examination from your physician. When using exercise equipment, basic precautions should always be taken, including the following:

- * Read all instructions before using the equipment. These instructions are written to ensure your safety and to protect the unit.
- * Do not allow children on or near the equipment.
- * Use the equipment only for its intended purpose as described in this guide. Do not use accessory attachments that are not recommended by the manufacturer: such attachments might cause injuries.
- * Wear proper exercise clothing and shoes for your workout----no loose clothing.
- * Be careful when getting on or off the equipment.
- * Do not overexert yourself or work to exhaustion.
- * If you feel any pain or abnormal symptoms, stop your workout immediately and consult your physician.
- * Never operate the unit when it has been dropped or damaged.
- * Never drop or insert anything into any opening in the equipment.
- * Always check the unit and its cables before each use. Make sure that all fasteners and cables are secure and in good working condition.
- * Frayed or worn cables can be dangerous and may cause injury. Periodically check these cables for any indication of wear.
- * Keep hands, limbs, loose clothing and long hair well out of the way of moving parts.
- * Do not attempt to lift more weight than you can control safely.
- * Do not use the equipment outdoors.

Personal Safety During Assembly

- * Read each step in the assembly instructions and follow the steps in sequence. Do not skip ahead. If you skip ahead, you may learn later that you have to disassemble components and that you may have damaged the equipment.
- * Assemble and operate the equipment on a solid, level surface. Locate the unit a few feet from walls or furniture to provide easy access. The equipment is designed for your enjoyment. By following these precautions and using common sense, you will have many safe and pleasurable hours of healthful exercise with the equipment.

Instructions

Before beginning assembly please take the time to read instructions thoroughly. Please use the various lists in this manual to make sure that all parts have been included in your shipment. When ordering, use part number and description from the lists. Use only our replacement part when servicing. Failure to do so will void your warranty and could result in personal injury.

The equipment is designed to provide the smoothest, most effective exercise motion possible. After assembly, you should check all functions to ensure correct operation. If you experience problems, first recheck the assembly instructions to locate any possible errors made during assembly. If you are unable to correct the problem, call your authorized dealer. Be sure to have your serial number and this manual when calling. When all parts have been accounted for, continue on.

Tools Required

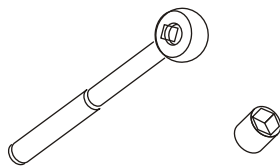

Ratchet Wrench and Socket

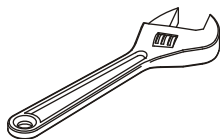

Adjustable Wrench

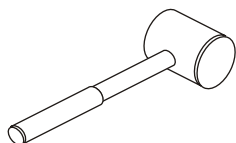

Rubber Mallet

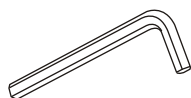

Hex Key Wrench Set

Parts List

NOTE: SOME OF THESE PARTS MAY COME PRE-INSTALLED

Item NO.	Part No.	Description	Qty
1	IF81090100	Weight Stack Frame	1
2	IF81200200	Lower Crossbeam	1
3	IF81200300	Middle Frame	1
4	IF81200400	Top Frame	1
5	IF81200500	U-shaped Frame	1
6	IF81200600	Left Frame	1
7	IF81200700	Right Frame	1
8	IF81200800	Back Pad Support	1
9	IF81200900	Foot Frame	2
10	IF81201000	Elbow Frame	2
11	IF81201100	Left Handle	1
12	IF81201200	Right Handle	1
13	IF81201300	Swing Frame	1
14	IF81201400	Leg Pad Frame	1
15	IF81201500	Cable 1	1
16	IF81201600	Leg Pad	1
17	IF81024300	Pop Pin	1
18	IF81161400	Guide Rod $\Phi 25 \times 2.5 \times 1229$	2
19	IF81201900	Cable 2	1
20	IF81202000	Adjustable Plate	1
21	IN-S51303500	Grip	4
22	IF81163500	Selector Pin W/Coil	1
23	PL90165400	Top Plate	1
24	IF81223900	Mount Sleeve	2
25	IF81162700	Plastic Plate	2
26	IF81162100	Shroud Clip	4
27	PTSHILO12800	Weight Rubber Bumper	2
28	SG500110400	4.5" Pulley	7
29	IFPT1300	Back Pad	1
30	IFPT1000	Elbow Pad	2
31	IF81061500	Front Shroud	1
32	IF81211600	Rear Shroud	1
33	IF81162200	Top Shroud	1
34	IF81212300	Plastic Knob - Cap	4
35	IF81212400	Plastic Knob - Base	4
36	TLP-2002100	Plug Bumper	2
37	SPT-62200	Foot Plate	2
38	KF18606200	Plug $\square 50.8$	6

Parts List

NOTE: SOME OF THESE PARTS MAY COME PRE-INSTALLED

Item No.	Part No.	Description	Qty
39	BNH0573	Plug Φ 32	4
40	KF18606000	Plug \square 50*25	2
41	V39900	Small Bumper	1
42	IF81162000	Foot Cover	4
43	IN-D21103500	Shaft	2
44	H2-A070	Spacer	1
45	M02502000	Bushing	4
46	CWRVL0014000	Y Bracket	2
47	GB77M8*8DS18	Socket Set Screw M8*8	4
48	PNLM8*20DS2	Button Head Cap Screw M8*20	2
49	PNLM6*15DS2	Button Head Cap Screw M6*15	2
50	CNLM10*30*30DS2NL	Flat Head Cap Screw M10*30	4
51	GB819M5*16DS2	Flat Philips Screw M5*16	8
52	IF81205200	Weight Connecting bolt	1
53	GB5781M12*30DS20NL	Hex Head Bolt M12*30	2
54	GB5780M10*110*30DS20NL	Hex Head Bolt M10*110*30	1
55	GB5780M10*100DS20	Hex Head Bolt M10*100	2
56	GB5780M10*105DS20	Hex Head Bolt M10*105	3
57	GB5780M10*80DS20	Hex Head Bolt M10*80	16
58	GB5780M10*75DS20NL	Hex Head Bolt M10*75 (nylon patch)	2
59	GB5780M10*75DS20	Hex Head Bolt M10*75	19
60	GB5780M10*50DS20	Hex Head Bolt M10*50	9
61	GB5780M10*45DS20	Hex Head Bolt M10*45	1
62	GB5780M10*35DS20	Hex Head Bolt M10*35	2
63	DQ12DS2A	Flat Washer Φ 13* Φ 24*1.5	2
64	DQ10DS2A	Flat Washer Φ 11* Φ 23*2	90
65	DQ10DS2D	Flat Washer Φ 11* Φ 38*2	6
66	GB958DS2	Flat Washer Φ 9* Φ 16*1.6	2
67	DQ6DS2A	Flat Washer Φ 6.6* Φ 15*2	2
68	NM10DS2	Nylon lock Nut M10	42
69	NM8DS2	Nylon lock Nut M8	2
70	IF81212700	Nut	4
74	NBS4DHS	Hex Key S=4	1
75	NBS5DHS	Hex Key S=5	1
76	NBS6DHS	Hex Key S=6	1
77	LW200BS	Wrench Φ 6*117	1
78	YHY	Lube	1

Parts List-Weight Plates

! There are three configuration of weights: 170LBS/200LBS/250LBS, please see following form for details.

Weight Plate 170LBS

Item No.	Part No.	Description	Qty
79	PLWS1000	Weight Plate 10LBS	16

Weight Plate 200LBS

Item No.	Part No.	Description	Qty
79	PLWS1000	Weight Plate 10LBS	10
80	IF8WS1500	Weight Plate 15LBS	6

Weight Plate 250LBS

Item No.	Part No.	Description	Qty
80	IF8WS1500	Weight Plate 15LBS	16

Exploded View

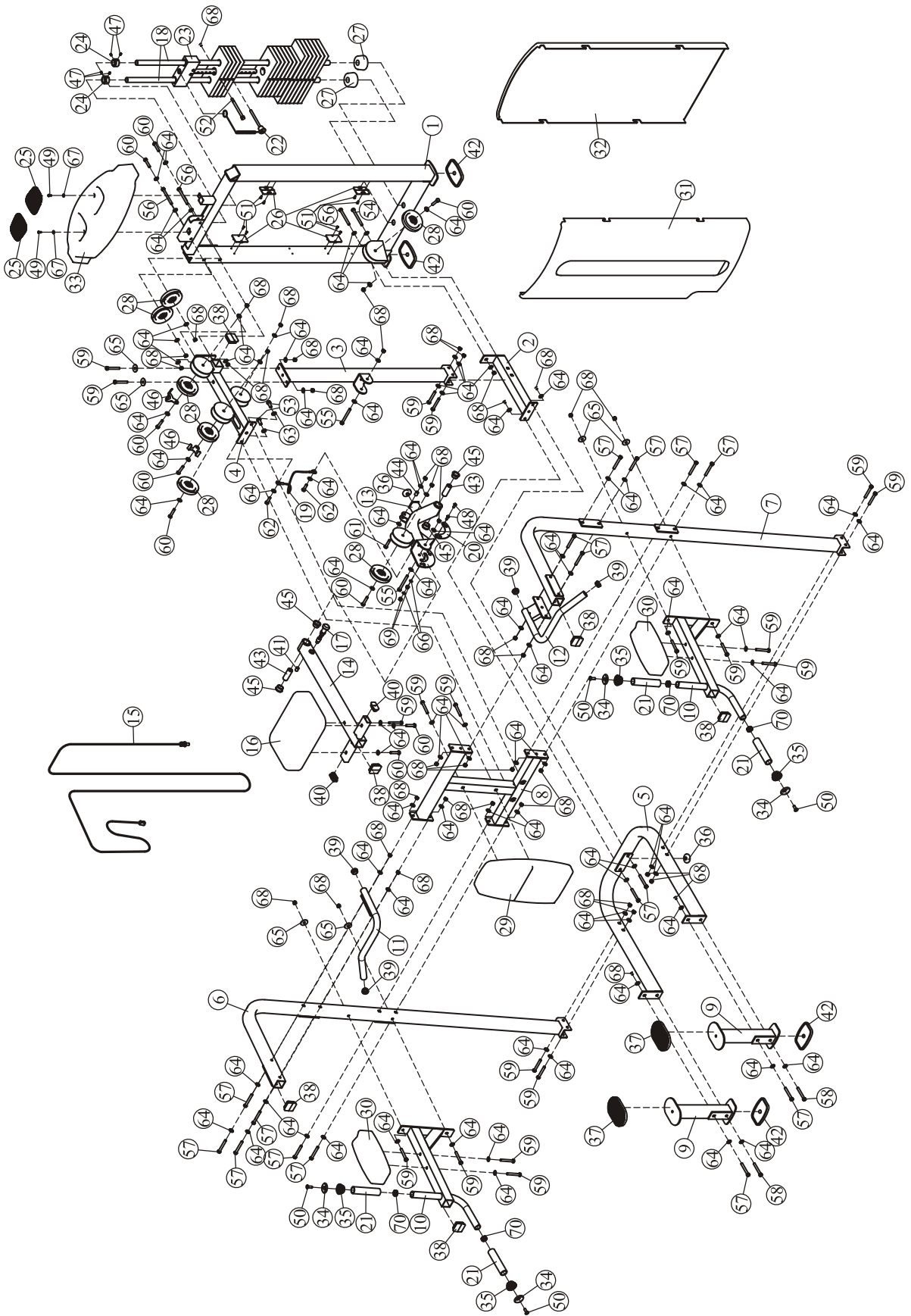

Measurement Guide

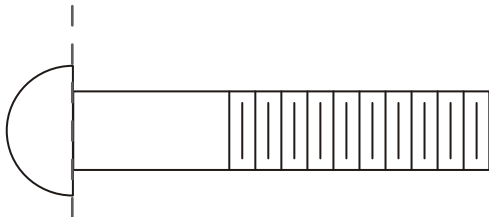

BHCS = Button Head Cap Screw

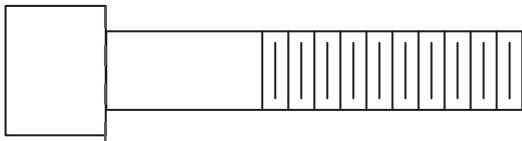

SHCS = Socket Head Cap Screw

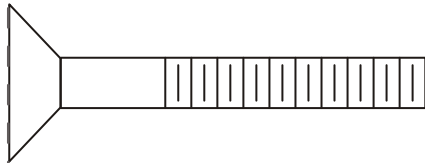

FHCS = Flat Head Cap Screw

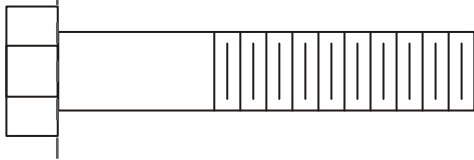

HHB = Hex Head Bolt

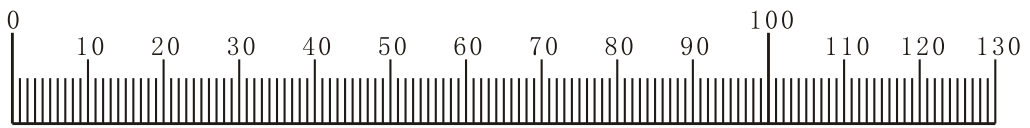

Millimeters

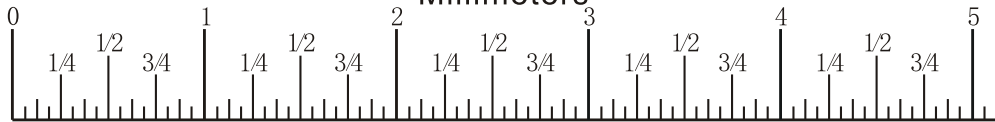

Inches

Assembly Instructions

Assembly of the equipment takes professional installers about 2 hours. If this is the first time you have assembled this type of equipment, plan to spend more time. It is strongly recommended to assemble the equipment by professional installers. You may find it quicker, safer, easier to assemble this equipment with the help of a friend, as some of components may be large, heavy or awkward to handle alone. It is important that you assemble your product in a clean, clear, uncluttered area. This will enable you to move around the product while you are fitting components and reduce the possibility of injury during assembly.



Note

As with any assembled part, proper alignment and adjustment is critical. While tightening the fasteners, be sure to leave room for adjustments. Do not fully tighten the fasteners until instructed to do so. Be careful to assemble the components in the sequence presented in this guide.

Assembly

Step 1

1. Attach the Lower Crossbeam (#2) to the Weight Stack Frame (#1) using:

one M10*105 HHB (#56) one M10*110*30 HHB (#54)
three Φ 11* Φ 23*2 Flat Washers (#64) one M10 Nylon Lock Nut (#68)

2. Attach the Middle Frame (#3) to the Lower Crossbeam (#2) using:

two M10*75 HHB (#59) four Φ 11* Φ 23*2 Flat Washers (#64)
two M10 Nylon Lock Nut (#68)

3. Attach the Top Frame (#4) to the Middle Frame (#3) & the Weight Stack Frame (#1) using:

two M10*105 HHB (#56) two M10*75 HHB (#59)
six Φ 11* Φ 23*2 Flat Washers (#64) two Φ 11* Φ 38*2 Flat Washers (#65)
four M10 Nylon Lock Nut (#68)

4. Attach the U-shaped Frame (#5) to the Lower Crossbeam (#2) using:

two M10*80 HHB (#57) four Φ 11* Φ 23*2 Flat Washers (#64)
two M10 Nylon Lock Nut (#68)

5. Attach the Left Frame (#6), the Right Frame (#7) to the U-shaped Frame (#5) using:

four M10*75 HHB (#59) eight Φ 11* Φ 23*2 Flat Washers (#64)
four M10 Nylon Lock Nut (#68)

6. Attach the Back Pad Support (#8) to the Left Frame (#6), the Right Frame (#7) using:

eight M10*80 HHB (#57) sixteen Φ 11* Φ 23*2 Flat Washers (#64)
eight M10 Nylon Lock Nut (#68)

7. Attach the Top Frame (#4) to the Back Pad Support (#8) using:

two M12*30 HHB (#53) two Φ 13* Φ 24*1.5 Flat Washers (#63)

8. Attach four Shroud Clips (#26) to the Weight Stack Frame (#1) using:

eight M5*16 Flat Philips Screws (#51)

Note: Hand tighten bolts and Nylon Lock Nuts until machine is fully assembled.

Assembly

Step 1

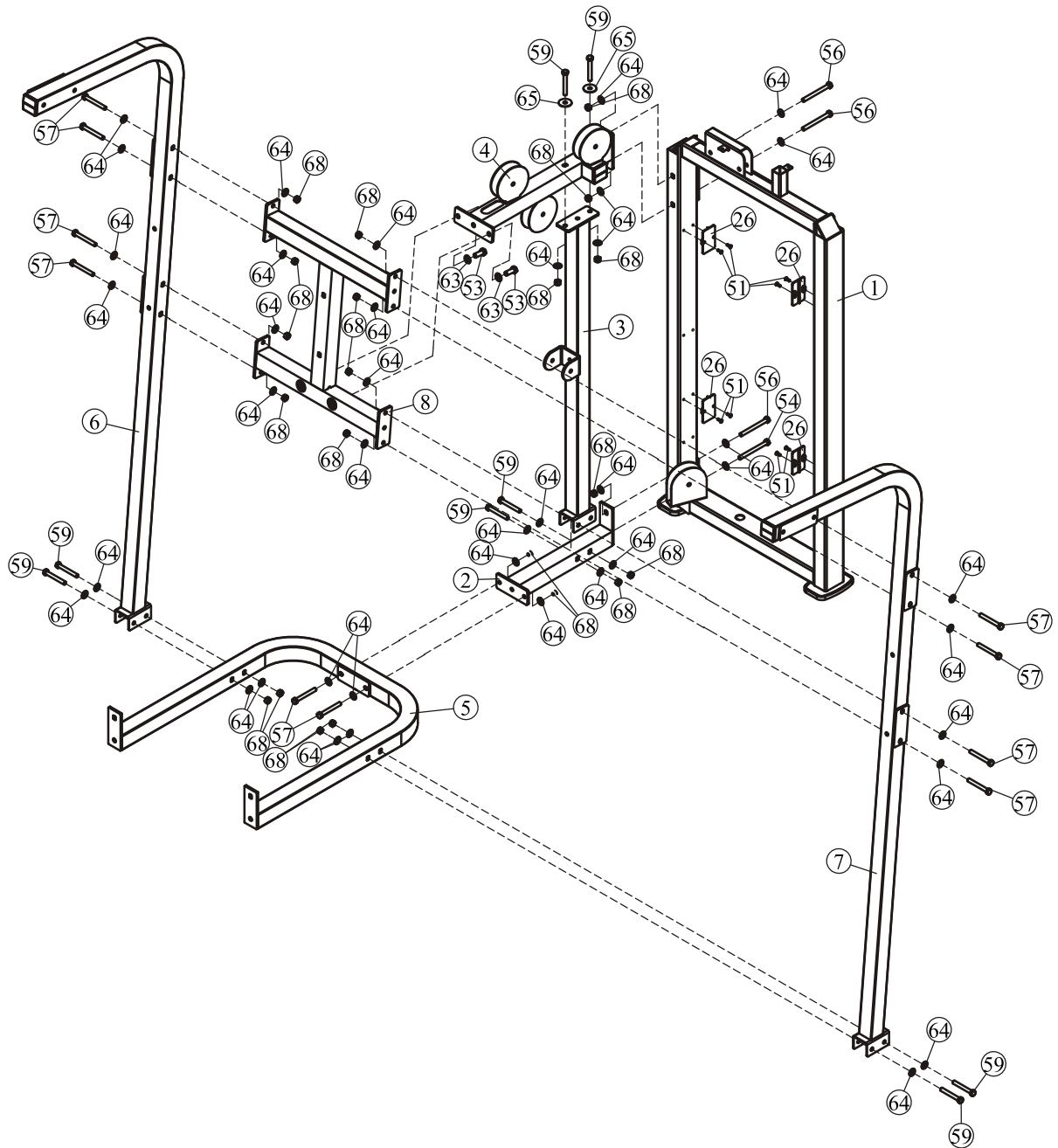

Assembly

Step 2

1. Attach the Foot Frame (#9) to the U-shaped Frame (#5) using:

two M10*80 HHB (#57)	two M10*75 HHB (nylon patch) (#58)
six $\Phi 11*\Phi 23*2$ Flat Washers (#64)	two M10 Nylon Lock Nut (#68)
2. Attach the Elbow Frame (#10) to the Left Frame (#6) & the Right Frame (#7) using:

four M10*75 HHB (#59)	four $\Phi 11*\Phi 23*2$ Flat Washers (#64)
four $\Phi 11*\Phi 38*2$ Flat Washers (#65)	four M10 Nylon Lock Nut (#68)
3. Attach the Left Handle (#11), Right Handle (#12) to the Left Frame (#6) & the Right Frame (#7) using:

four M10*80 HHB (#57)	eight $\Phi 11*\Phi 23*2$ Flat Washers (#64)
four M10 Nylon Lock Nut (#68)	
4. Attach the Swing Frame (#13) to the Middle Frame (#3) using:

one M10*100 HHB (#55)	two $\Phi 11*\Phi 23*2$ Flat Washers (#64)
one M10 Nylon Lock Nut (#68)	
5. Attach the Leg Pad Frame (#14) to the Swing Frame (#13) using:

one M10*100 HHB (#55)	two $\Phi 11*\Phi 23*2$ Flat Washers (#64)
one M10 Nylon Lock Nut (#68)	

Note: Hand tighten bolts and Nylon Lock Nuts until machine is fully assembled.

Step 3

1. Attach three 4.5" Pulley (#28) to the Weight Stack Frame (#1) using:

three M10*50 HHB (#60)	six $\Phi 11*\Phi 23*2$ Flat Washers (#64)
three M10 Nylon Lock Nut (#68)	
2. Attach three 4.5" Pulley (#28) to the Top Frame (#4) using:

three M10*50 HHB (#60)	two Y Bracket (#46)
six $\Phi 11*\Phi 23*2$ Flat Washers (#64)	three M10 Nylon Lock Nut (#68)
3. Attach one 4.5" Pulley (#28) to the Swing Frame (#13) using:

one M10*50 HHB (#60)	two $\Phi 11*\Phi 23*2$ Flat Washers (#64)
one M10 Nylon Lock Nut (#68)	
4. Attach the Cable 1 (#15) to the Swing Frame (#13) using:

one M10*45 HHB (#61)	one $\Phi 10*\Phi 14*20$ Spacer (#44)
two $\Phi 11*\Phi 23*2$ Flat Washers (#64)	one M10 Nylon Lock Nut (#68)
5. Attach the Cable 2 (#19) to the Top Frame (#4) & the Swing Frame (#13) using:

two M10*35 HHB (#62)	two $\Phi 11*\Phi 23*2$ Flat Washers (#64)
----------------------	--

Note: Hand tighten bolts and Nylon Lock Nuts until machine is fully assemble.

Assembly

Step 2

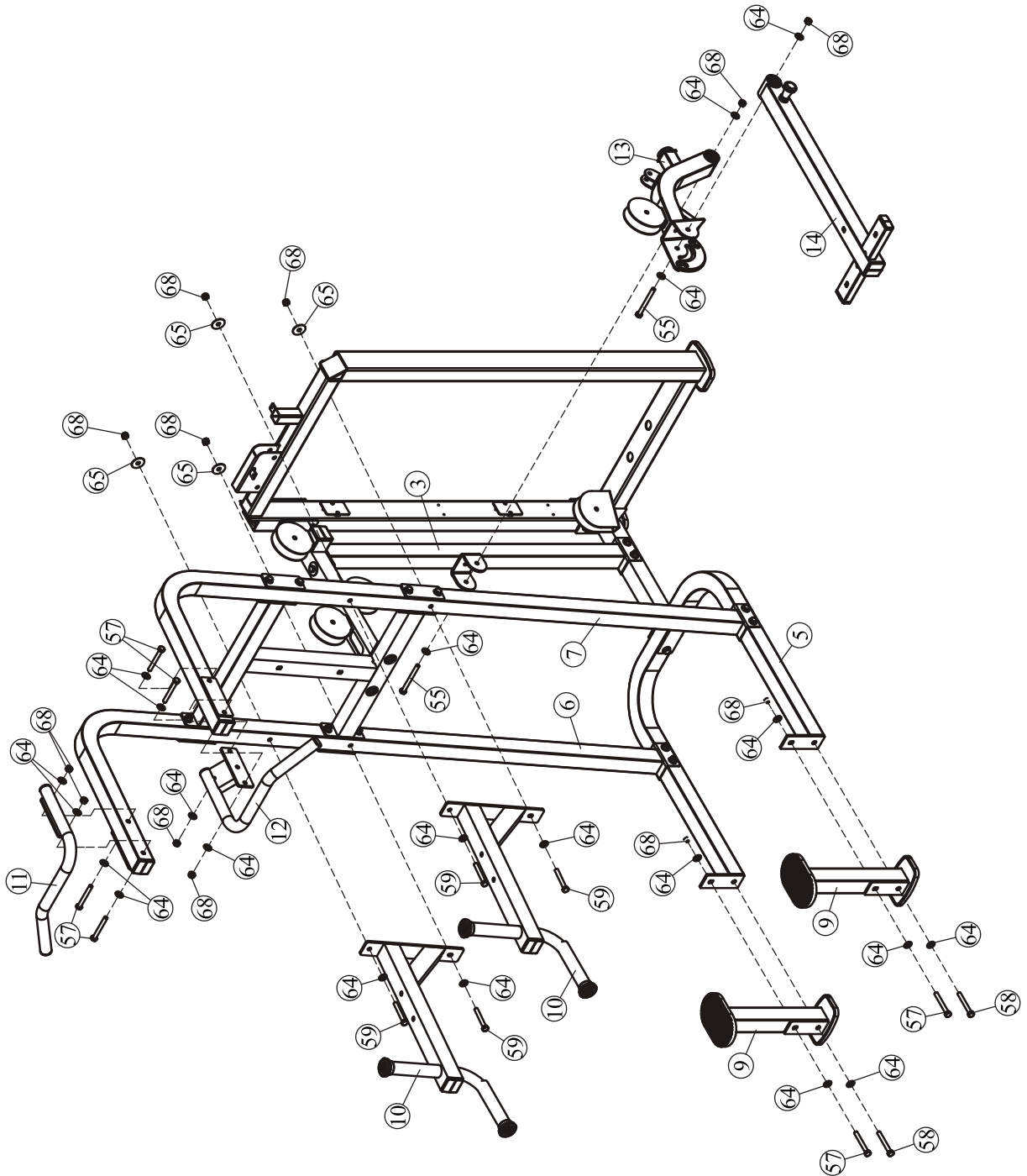

Assembly

Step 3

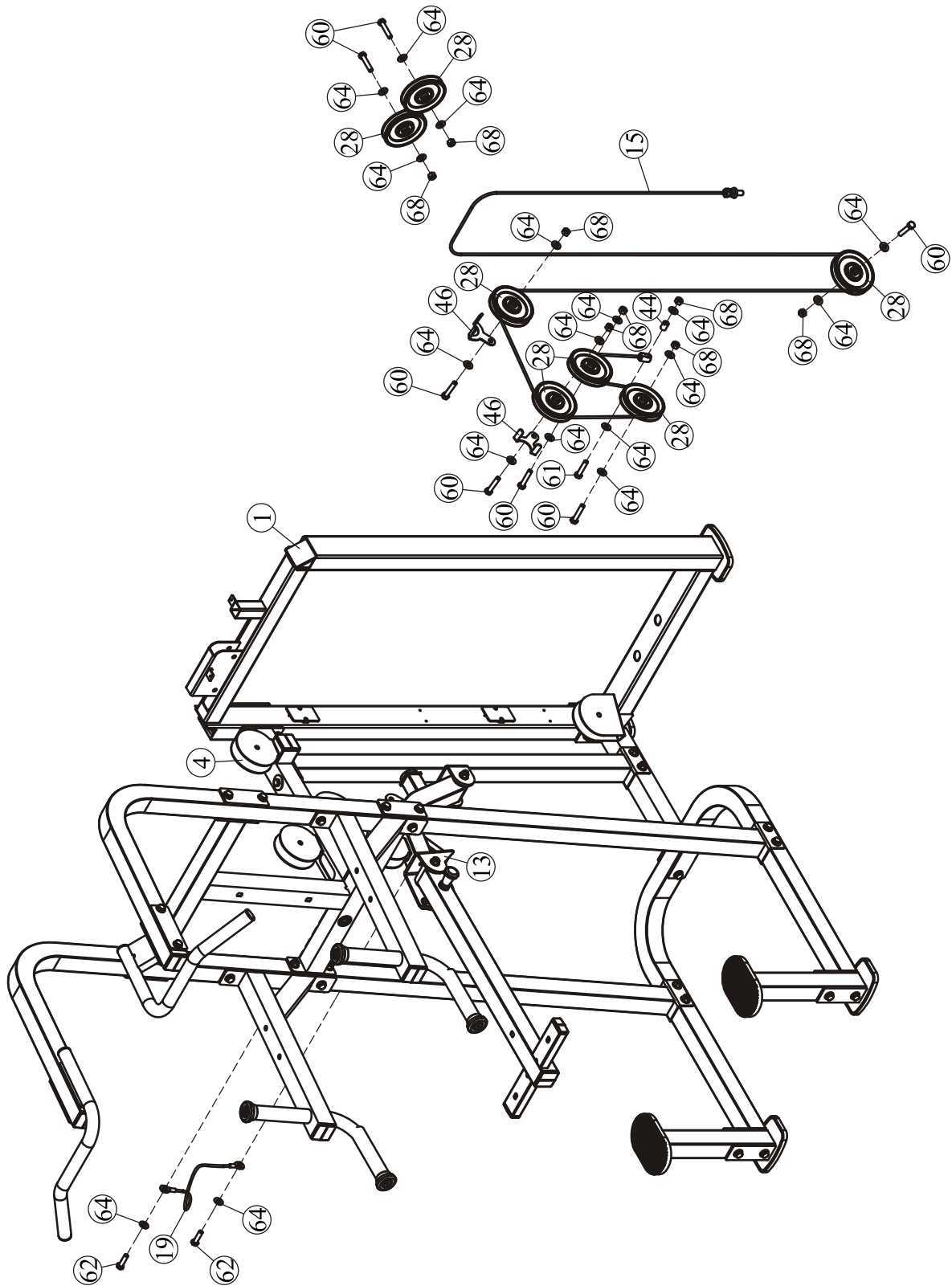

Assembly-170LBS

Step 4

Attach:

two $\Phi 25 \times 2.5 \times 1229$ Guide Rod (#18)

two $\Phi 76.2 \times \Phi 26.9 \times 38.1$ Weight Rubber Bumper (#27)

sixteen 10LBS Weight Plate (#79)

one Top Plate (#23)

to the Weight Stack Frame (#1) using:

two $\Phi 40 \times \Phi 25.3 \times 25 \times M8$ Mount Sleeve (#24)

four M8*8 Socket Set Screws (#47)

Attach the Top one Weight Plate to the Top Plate (#23) using:

one $\Phi 18 \times 145$ Weight Connecting bolt (#52)

one M10 Nylon Lock Nut (#68)

Attach the Selector Pin W/Coil (#22) to Top Plate (#23).

Attach the Cable 1 (#15) to the Top Plate (#23).

Note: Hand tighten bolts and Nylon Lock Nuts until machine is fully assembled.

*Here is the assembly instruction for 170LBS weights.
Please assemble according to the actual weights you buy.*

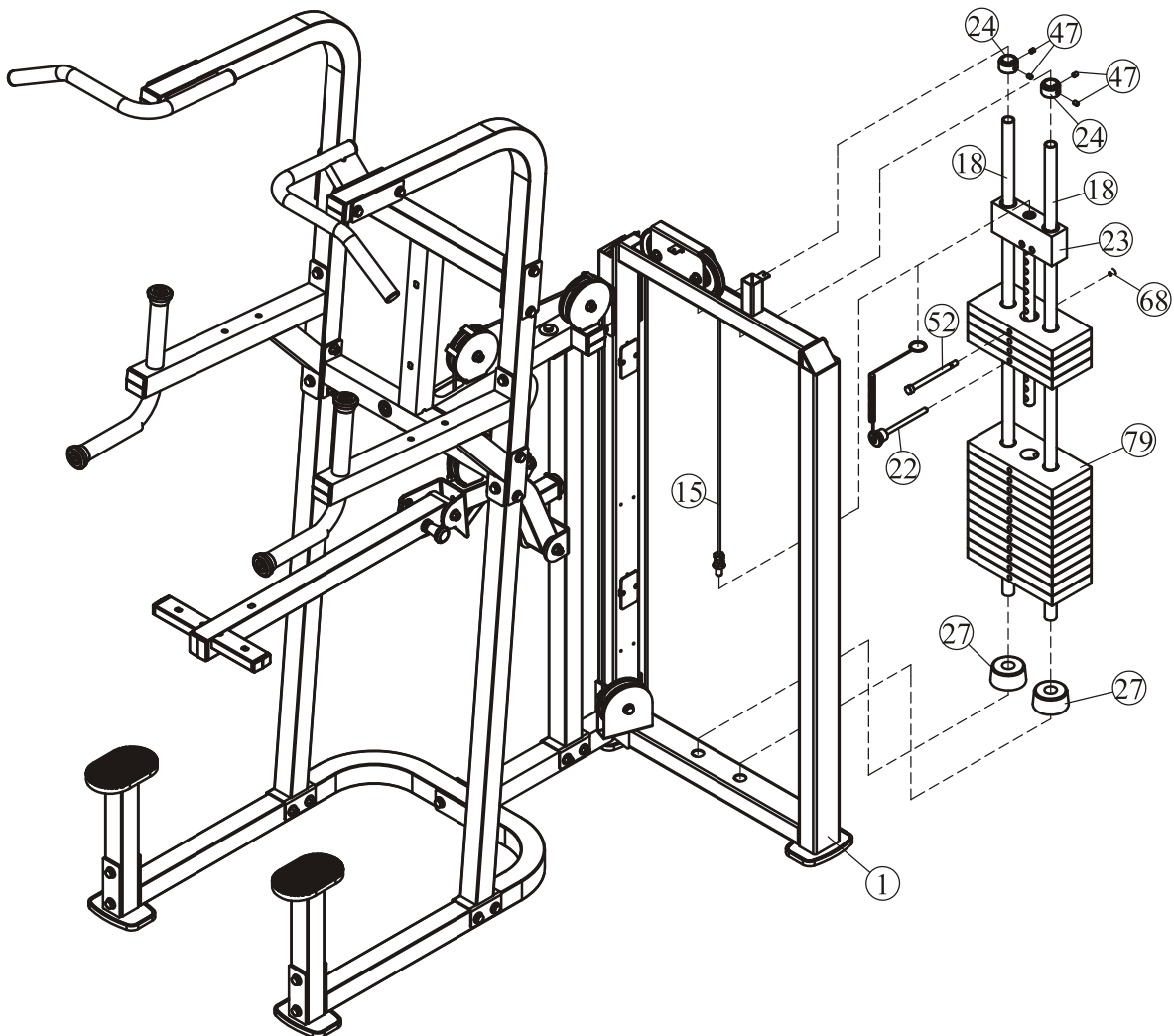

Assembly-200LBS

Step 4

Attach:

two $\Phi 25 \times 2.5 \times 1229$ Guide Rod (#18)

two $\Phi 76.2 \times \Phi 26.9 \times 38.1$ Weight Rubber Bumper (#27)

ten 10LBS Weight Plate (#79)

six 15LBS Weight Plate (#80)

one Top Plate (#23)

to the Weight Stack Frame (#1) using:

two $\Phi 40 \times \Phi 25.3 \times 25 \times M8$ Mount Sleeve (#24)

four M8*8 Socket Set Screws (#47)

Attach the Top one Weight Plate to the Top Plate (#23) using:

one $\Phi 18 \times 145$ Weight Connecting bolt (#52)

one M10 Nylon Lock Nut (#68)

Attach the Selector Pin W/Coil (#22) to Top Plate (#23).

Attach the Cable 1 (#15) to the Top Plate (#23).

Note: Hand tighten bolts and Nylon Lock Nuts until machine is fully assembled.

*Here is the assembly instruction for 200LBS weights.
Please assemble according to the actual weights you buy.*

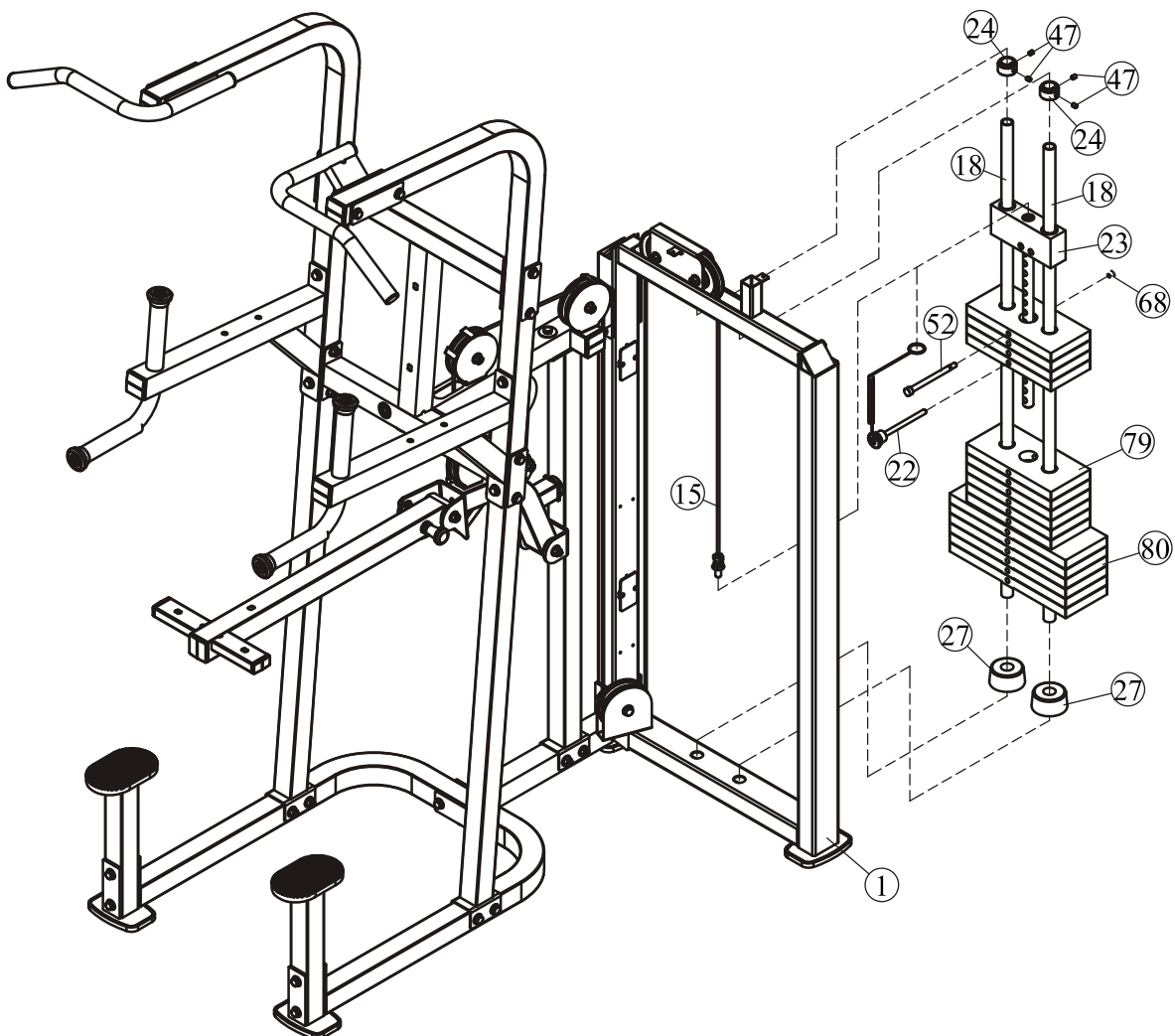

Assembly-250LBS

Step 4

Attach:

two $\Phi 25 \times 2.5 \times 1229$ Guide Rod (#18)

two $\Phi 76.2 \times \Phi 26.9 \times 38.1$ Weight Rubber Bumper (#27)

sixteen 15LBS Weight Plate (#80)

one Top Plate (#23)

to the Weight Stack Frame (#1) using:

two $\Phi 40 \times \Phi 25.3 \times 25 \times M8$ Mount Sleeve (#24)

four M8*8 Socket Set Screws (#47)

Attach the Top one Weight Plate to the Top Plate (#23) using:

one $\Phi 18 \times 145$ Weight Connecting bolt (#52)

one M10 Nylon Lock Nut (#68)

Attach the Selector Pin W/Coil (#22) to Top Plate (#23).

Attach the Cable 1 (#15) to the Top Plate (#23).

Note: Hand tighten bolts and Nylon Lock Nuts until machine is fully assembled.

*Here is the assembly instruction for 250LBS weights.
Please assemble according to the actual weights you buy.*

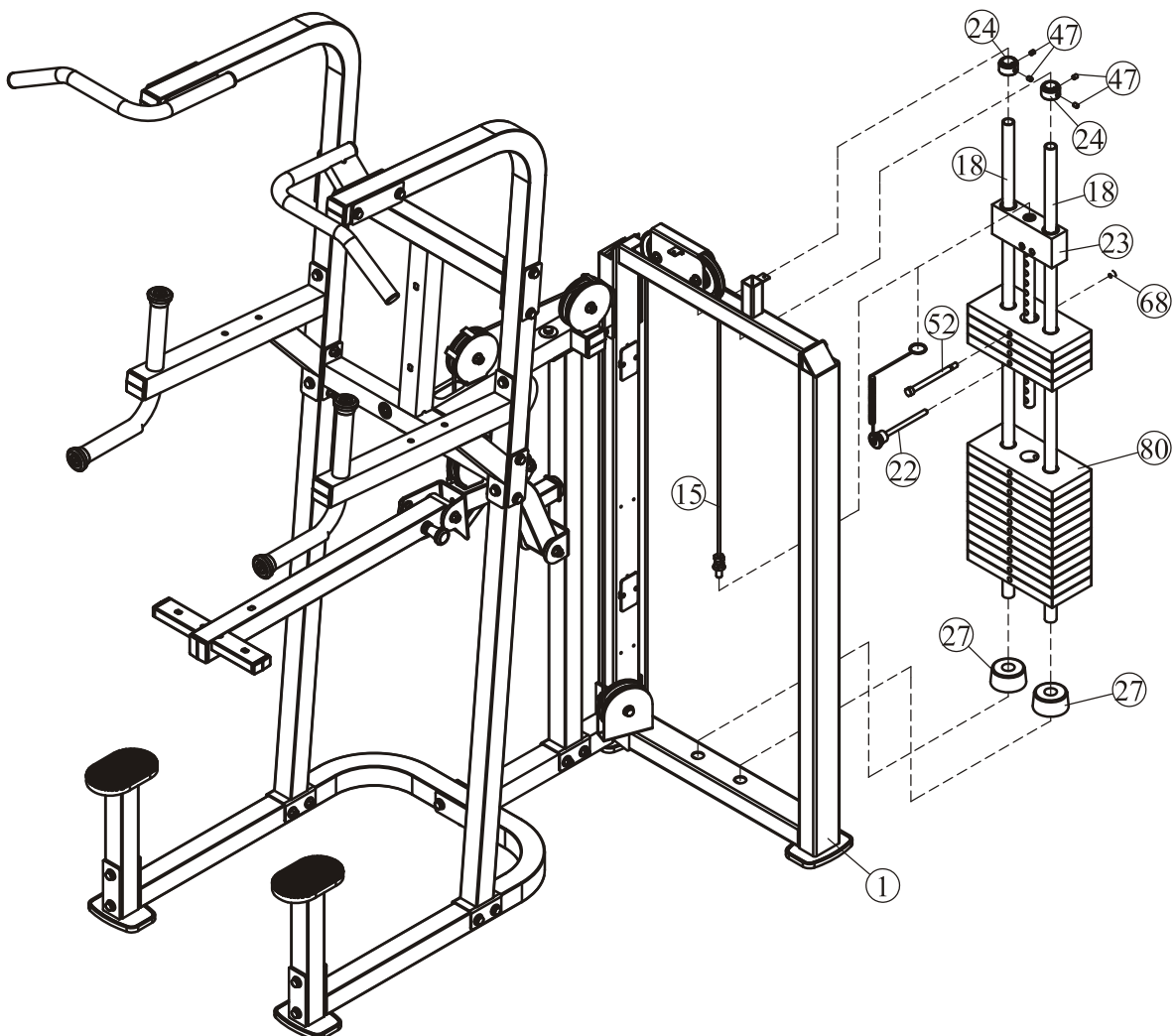

Assembly

Step 5

1. Attach the Leg Pad (#16) to the Leg Pad Frame (#14) using:
two M10*50 HHB (#60) one M10*75 HHB (#59)
three $\Phi 11 \times \Phi 23 \times 2$ Flat Washers (#64)
2. Attach the Back Pad (#29) to the Back Pad Support (#8) using:
two M10*75 HHB (#59) two $\Phi 11 \times \Phi 23 \times 2$ Flat Washers (#64)
3. Attach the Elbow Pad (#30) to the Elbow Frame (#10) using:
four M10*75 HHB (#59) four $\Phi 11 \times \Phi 23 \times 2$ Flat Washers (#64)

Note: Wrench Tighten bolts and Nylon Lock Nuts.

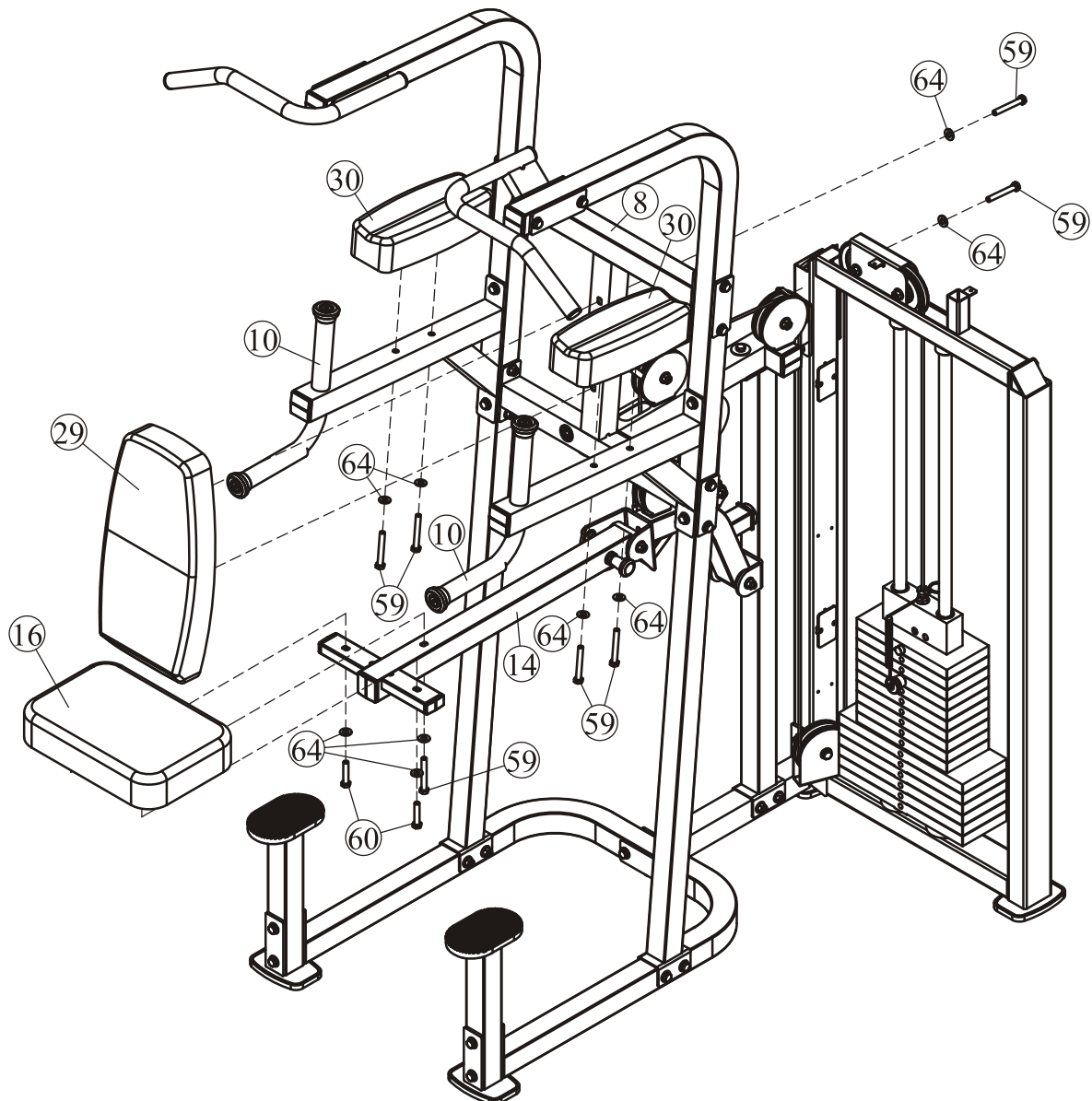

Assembly

Step 6

1. Attach the Front Shroud (#31) and the Rear Shroud (#32) to the Weight Stack Frame (#1).
 2. Attach the Top Shroud (#33) to the Weight Stack Frame (#1), using:
two M6*15 BHCS (#49) two $\Phi 6.6 \times \Phi 15 \times 2$ Flat Washers (#67)
- Note:** Wrench Tighten bolts and Nylon Lock Nuts.
3. Attach two 128.5*121.9*1.5 Plastic Plate (#25) to the Top Shroud (#33).

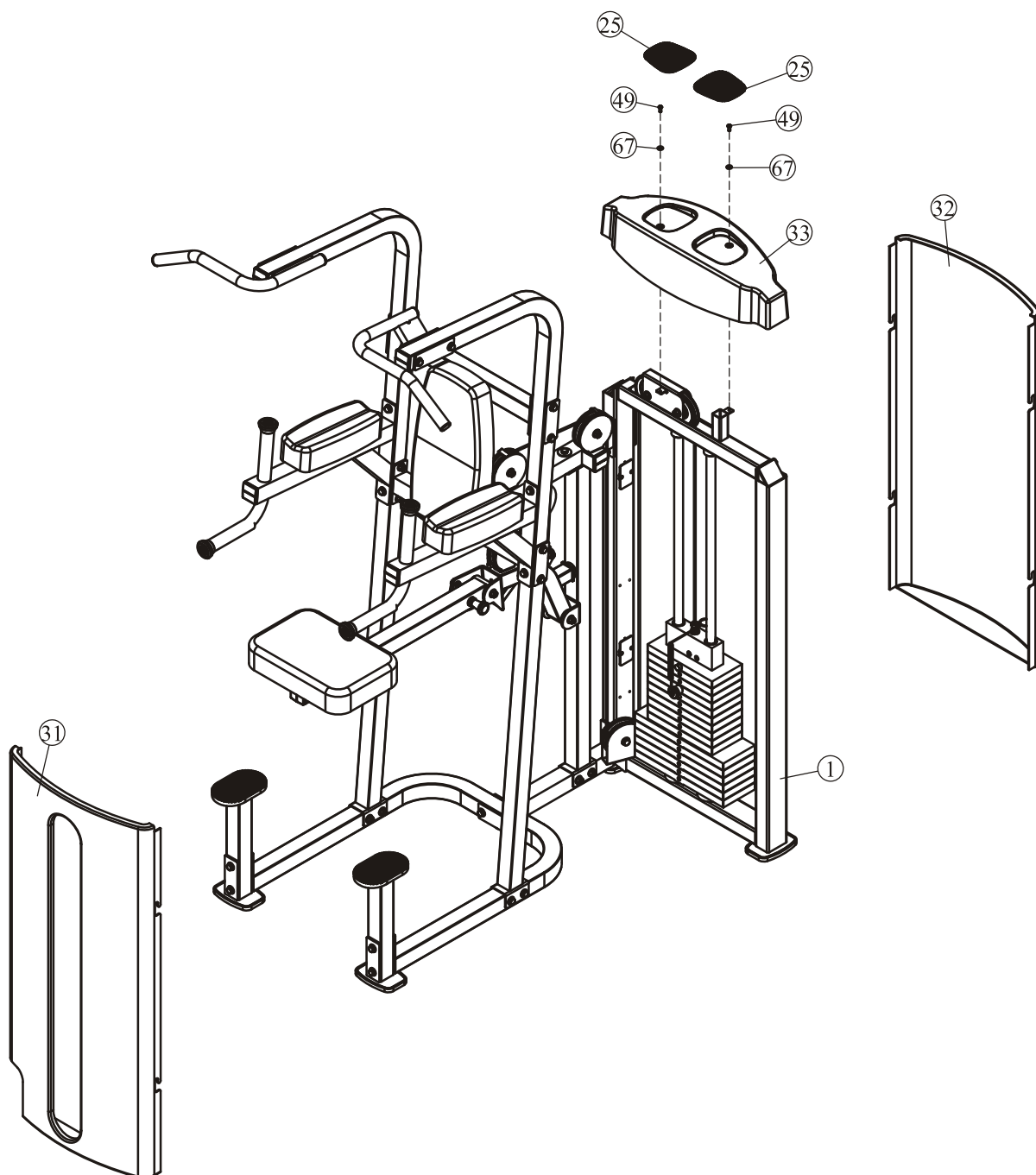

Exercise Instructions

WEIGHT ASSISTED CHIN/DIP COMBO

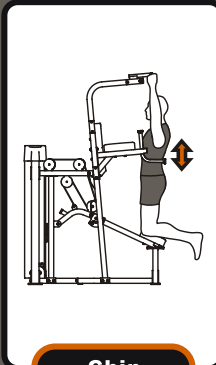

Chin

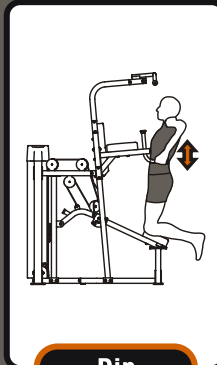

Dip

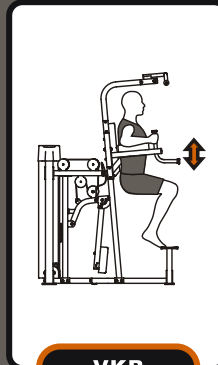

VKR

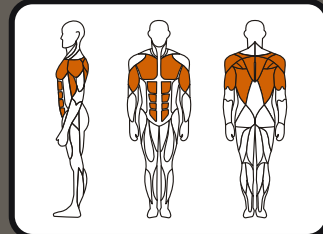

- 1 Select an appropriate weight.
- 2 Adjust knee pad for desired positioning.
- 3 For Chins: hold the middle handle and lift knees onto knee pad, lower body to start position while pulling body up to chin bar. For Dips: hold the up handle and lift knees onto knee pad, straighten arms while pushing upwards to begin exercise, while pressing body back to upper position.
- 4 Vertical Knee Raise/Dip.

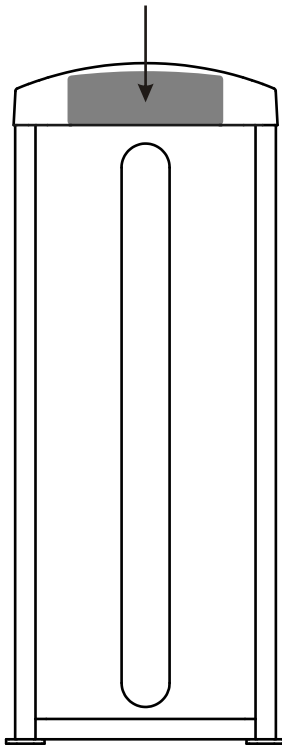

- 1 Select an appropriate weight.
- 2 Adjust knee pad for desired positioning.
- 3 For Chins: hold the middle handle and lift knees onto knee pad, lower body to start position, while pulling body up to chin bar. For Dips: hold the up handle and lift knees onto knee pad, straighten arms while pushing upwards to begin exercise, while pressing body back to upper position.
- 4 Vertical Knee Raise/Dip.

(Adjust weight according to the select pin)

Specifications

Class: S

Maximum Wt. Capacity: 113Kg/ 250lbs.

Maximum Load of Trainer: 150Kg/ 330lbs.

Maintenance Schedule

ROUTINE	COMMERCIAL MAINTENANCE	HOME MAINTENANCE	LATEST DATE ENTRY					
Inspect; Links, Pull Pins, Snap Locks, Swivels, Weight Stack Pins	DAILY	WEEKLY						
Clean; Upholstery	DAILY	WEEKLY						
Inspect; Cables or Belts and their tension	DAILY	WEEKLY						
Inspect; Accessory Bars, and Handles	WEEKLY	3 MONTHS						
Inspect; All Decals	WEEKLY	3 MONTHS						
Inspect; All Nuts and Bolts, Tighten if needed	WEEKLY	3 MONTHS						
Inspect; Anti-Skid Surface	WEEKLY	3 MONTHS						
Clean & Lubricate; Guide Rods with a Teflon (PTFE) based lubricant (Superlube)	MONTHLY	3 MONTHS						
Lubricate; Seat Sleeves, Turcite Bushings, Linear Bearing	MONTHLY	3 MONTHS						
Clean and Wax; All Glossy Finishes	6 MONTHS	YEARLY						
Repack with Grease; Linear Bearings	6 MONTHS	YEARLY						
Replace; Cables, Belts and Connecting Parts	YEARLY	3 YEARS						

Your equipment comes with a commercial maintenance decal. For personal, in home use, please follow the home maintenance schedule listed above.

General Maintenance Information

Links, Pull-Pins, Snap Hooks, Swivels, Weight Stack Pins:

- *Check all pieces for signs of visible wear or damage.
- *Check springs in snap hooks and pull-pins for proper tension and alignment.
- *If the spring sticks or has lost its rigidity, replace it immediately.

Upholstery:

- *To ensure prolonged upholstery life and proper hygiene, all upholstered pads should be wiped down with a damp cloth after every workout.
- *Periodically take the time to use a mild soap or an approved vinyl upholstery cleaner to deter the onset of cracking or drying. Avoid using any abrasive cleaners or cleaners not intended for use on vinyl.
- *Replace ripped or worn upholstery immediately.
- *Keep sharp or pointed objects clear of all upholstery.

Decals:

- *Inspect and familiarize yourself with any safety warnings or other user information posted on each decal.

Nuts and Bolts:

- *Inspect all nuts and bolts for any loosening and tighten if needed.
- *Go through a re-tightening sequence periodically to ensure that all hardware is tensioned proper.

Anti-Skid Surfaces:

- *These surfaces are designed to supply secure footing and need to be replaced if they appear worn or become slippery.

Belts and Cables:

- *We use only high quality belt, and mil-spec cables.
- *Visually inspect the belts and cables for fraying, cracking, peeling or discoloration.
- *While the machine is not in use, carefully run your fingers along the belt or cable to feel for thinning or bulging areas.
- *Replace belts and cables immediately at the first signs of damage or wear. Do not use equipment until belts or cables have been replaced.

Belt and Cable Tension:

- *Referring to the Owners Manual, when belts or cables are used check all bolt attachments to be sure they are properly attached.
- *Check slack in cables and re-adjust cable tension if needed.

Seat Sleeves, Guide Rods:

- *Wipe down adjusting tubes with a dust free rag before applying lubricant.
- *Lubricate seat sleeves and Guide Rods with a Silicon or Teflon based lubricant spray.

Linear Bearings:

- *Referring to the Owners Manual carefully disassemble the bearing from its housing and place a finger full of light grease (lithium, super lube, etc.) into the inside of the bearing. Using your finger, press the grease into the ball-bearings and their tracks. Repeat until the ball-bearing tracks are full of grease. Insert the shaft back into the bearing and wipe off excess grease.

PLEASE KEEP THIS FOR YOUR RECORDS

Weight Training Tips

Use this manual to guide you through the basic exercises you can perform on your equipment. To gain maximum results and avoid possible injury, consult a fitness professional to develop your complete exercise program.

Always consult your physician before starting any exercise program.

To be successful in your exercise program, it is important to develop an understanding of the basic principles of strength training. Now that you have your equipment, it is only natural that you want to get started immediately. First, determine a set of realistic goals and objectives for yourself. By deciding on an exercise plan that is right for you prior to starting, you will contribute significantly to your success.

Warm up properly before engaging in weight resistance training. Stretching, yoga, jogging, calisthenics or other cardiovascular exercise can help prepare your body for the heavier workload of lifting weights.

Learn how to perform the exercise correctly before using heavy weight. Correct form is important to avoid injury and to ensure that you work the proper muscle groups.

Know your limitations. If you are new to weight training or are embarking on an exercise regimen after a long layoff, start slowly and build foundational strength over a longer period of time.

Pay attention to your breathing. Exhale when you exert is a general rule of thumb. Never hold your breath.

