

Инструкция

Жим от груди и от плеч Bronze Gym M5-03 Dual

Полезные ссылки:

[Жим от груди и от плеч Bronze Gym M5-03 Dual - смотреть на сайте](#)

[Жим от груди и от плеч Bronze Gym M5-03 Dual - читать отзывы](#)

LYM5S-03



SEATED/HORIZONTAL SHOULDER PRESS

OWNER'S MANUAL

▲ Prior to assembling the machine and having your workout, please carefully read this manual. We assume that you have read it when you are using it.

▲ Please carefully fill out the warranty card and we'll retain it after your purchase. Mail the stub on payment receipt to us so we can offer you more quality services conveniently.

▲ This manual must be modified along with improvement and perfection of the machine and we'll not give further notice about it.

▲ This manual should be well retained so that you can read it at any time.

Note: Color and structure of the machine are subject to the real object while they may differ slightly in the figure from the actual ones. The company reserves the right to modify the product and will not provide further notice.

CONTENTS

SAFE USE NOTICES	1
DESIGN ILLUSTRATION	4
PRODUCT DESCRIPTION	5
SPECIFICATIONS	6
ASSEMBLY TOOLS	6
ASSEMBLY INSTRUCTIONS	7
TARGET MUSCLE DIAGRAM	11
USAGE GUIDANCE	12
EXERCISE NOTICES	14
MAINTENANCE&TROUBLE SHOOTING	15
PREVENTIVE MAINTENANCE	16
WARRANTY	21

SAFE USE NOTICES



Before using the machine, please carefully read this manual and get acquainted with operation process.

Keep this in mind: Please have an adequate warm-up prior to any workout in case of injuries. The manufacture and dealer assume no liability for any human injury or property damage caused by any disease or improper operation during usage.

If you take medicine when you are about to use the machine or start your workout, please consult your physician about whether it will affect your heart rate during workout. If you are suffering cardiac disease or over 35, you cannot use this machine unless consulting a physician and getting his permission.

Important Notices

Thank you for purchasing our product! It is the responsibility of the owner of the machine to ensure that all users have read this manual and gotten acquainted with warnings and safety precautions before using it.

1.This manual must be carefully read before usage of the machine. The machine can only be used strictly as described in this manual. It must be retained during the whole service life of the machine. (CAUTION)

2.The owner of the machine must ensure that all the users get acquainted with all the use notices.

3.Keep air fresh and ventilation good during usage of the machine. Also an adequate activity space must be ensured.

4.This machine is only intended for use in organizations with training areas, sport associations, clubs and educational establishments.

5.The maximum user weight is 150kg (330 pounds). (CAUTION)

6.It must be used under the supervision of a coach in case of any safety accident or damage to the machine. (WARNING)

7.Children under 14 must avoid using the machine in case of severe injuries or even physical disability while cardiac patients are prohibited from using the machine. (DANGER)

8.If at any time during exercise you feel dizziness, nausea or any other discomfort, stop immediately and consult your physician. (WARNING)

9.It must be located stably on an even floor in case of slips during the usage. Enough clearance must be kept for safe operation. Generally, a distance of 4 feet (1.2m) should be kept between the user and the centre of the surrounding space.

10.Select appropriate weight resistance and adjust position prior to exercise.

11.Check if all set screws are tightened and whether handgrips are well fastened prior to use. Otherwise, using it is prohibited in case of any accident. (WARNING)

12.Adjust steel cable to proper length, make sure it's solidly, securely connected and moves smoothly without any twist. Regular inspection must be implemented to avoid any error. If any problem, it must be solved by professionals instantly. For any fault with weight plate, guide rod or any other part, please contact professional to fix it immediately in case of accident as weight plates may fall off suddenly. (WARNING)

13.During exercise, please wear suitable sport dress and sport shoes, without dress or ornament and with hair tied up, in case of any interference to workout. (CAUTION)

14.5-10 minutes of warm-up exercise must be taken prior to exercising on the machine.

15.Injury to health may result from incorrect or excessive training, so please have workout in correct way, select appropriate weight resistance and exercise duration. Consult a coach if necessary. (CAUTION)

16.No touching steel cable or any moving parts during exercise in case of injury to fingers. (DANGER)

17. Do not return to the starting position too quickly in case of any damage to the weight plates, instead, you must slow down when it gets closed to the weight plate below. (WARNING)

18. The machine must be used in dry room in case of any damage.

19. Do not have movements beyond the machine's functions. (WARNING)

20. No adjustment to the machine which may interfere with users' exercises is allowed to be made. (DANGER)

21. Please exercise on the machine in correct way; incorrect method or exercise beyond the machine's function may bring damage to your health. (WARNING)

22. It's recommended that the machine is used in an supervised area.

23. Product Standards: EN ISO 20957-1 & EN 957-2

Warning: Violation of the safety rules above will result in personal injury and equipment damage.



Warning

In order to reduce the risk of burn, fire, electric shock and injury to other people, please obey the following regulations:

- It must be ensured that the SELECTOR PIN works normally prior to using the machine.
- If you feel chest pain, nausea, dizziness or tachypnea during workout, stop immediately and consult the professional.
- Do not wear clothing that can be easily caught in the machine.
- Wear suitable sportswear and sport shoes during exercise.
- Touching steel cable or machine parts in operation is prohibited.
- Movements beyond the machine's function are prohibited.
- Do not make any adjustment to any device which may interfere with user's exercises.
- Do not throw or tuck any foreign object into gaps.
- The machine is for one person at a time; never allow more than one person to use it at the same time.

DESIGN ILLUSTRATION

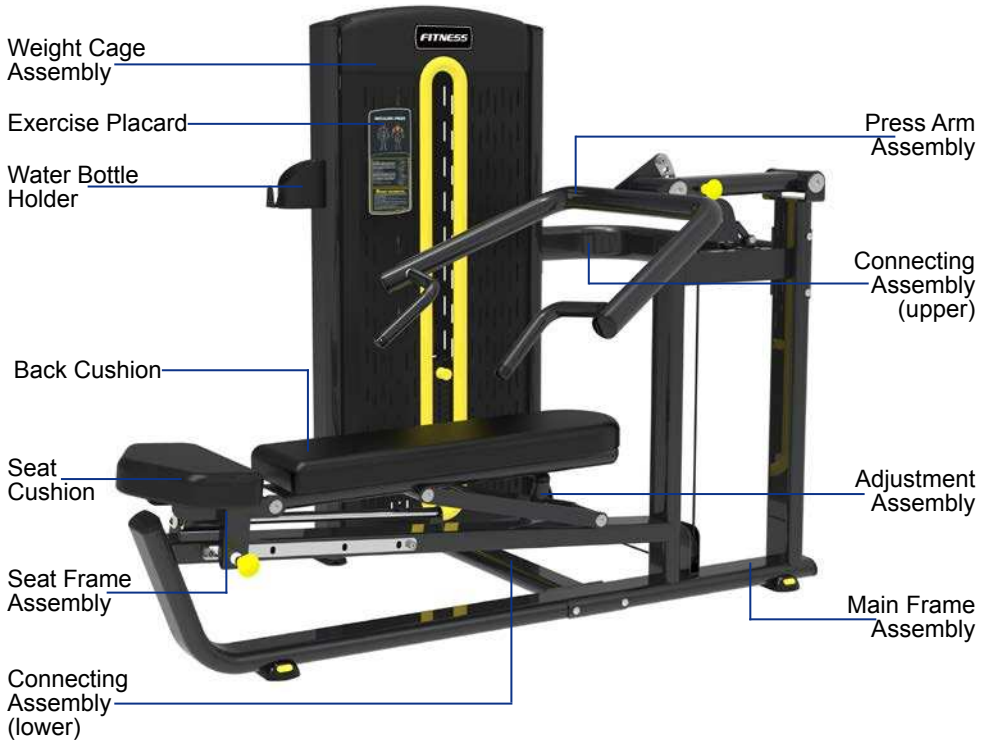

PRODUCT DESCRIPTION

Target muscles: Pectoralis major, Biceps Brachii, Triceps brachii, Deltoid muscle, Latissimus Dorsi, and Trapezius.

The unit has a scientific, reasonable structure, and simplified, elegant look. Due to the movement trajectory that complies with the principle of human engineering, the exercise is safe and comfortable.

Tower Frame: It is constituted of well welded quality flat oval tubes and quality steel which bring excellent solidity and durability.

Weight Cage: It perfectly protects users from weight stacks and enhances usage safety.

Links: High-end bearings used for links bring smoother movements.

Handgrips: Reasonably designed handgrips with high degrees of comfort make it easier for users to exert themselves and bring smoother movements.

Shroud: Made of quality steel plate.

Frame: Frame made of solidly welded quality flat oval tubes (50*120*(≥2.5T)/Q195) never deforms.

Cushion: Cushion made of PU foam with one-step forming technology is in compliance with the principle of human engineering and has a moderate softness.

Pulley: Safe and reliable pulleys are made of engineering plastics with injection molding technology.

Steel cables: 6x19+1 strand construction; quality stainless steel; durable, safe, reliable; maximum load: 1000KG.

SPECIFICATIONS

Unit Dimensions: 1460mm(L)×1950mm(W)×1535mm(H)

Weight Stack: 80kg (standard)

Unit weight: 215kg (standard weight stack included)

User Weight ≤ 150kg

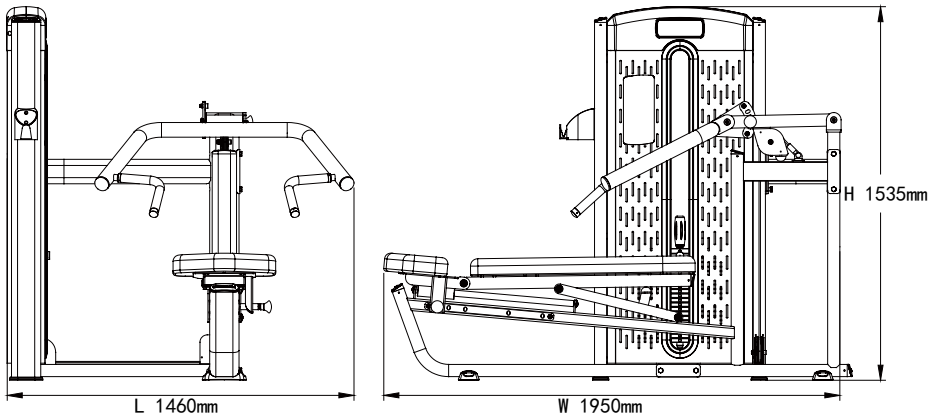

ASSEMBLY TOOLS

NO.	NAME	SPECIFICATION	QUANTITY
1	Screwdriver	Philips	1
2	Open-ended Spanner	17-19	2
3	Socket Wrench	19	1
4	Allen Wrench	8mm	1
5	Allen Wrench	6mm	1
6	Allen Wrench	5mm	1
7	Allen Wrench	4mm	1
8	Allen Wrench	3mm	1

ASSEMBLY INSTRUCTIONS

1. Verify that there's adequate space surrounding this piece of equipment prior to assembling it.

2. Open the packing box, take out the parts and remove all packing materials. Classify all parts and tidily put them on vacant floor.

3. Ensure that it's correctly assembled with all the parts according to assembly steps.

4. It requires at least two persons.

I. Assemble weight cage

(1) Dismantle rear shroud. Put it in safe area (No clashing or scratching!).

(2) Assemble weight plates. Insert two guide rods into the corresponding mounting holes on the lower part of weight cage; pass them through shock pads; pass them through weight plates successively.

(3) Assemble head plate. Now the weight plates are assembled.

(4) Assemble circlips on the upper parts of two guide rods; fix guide rods.

(5) Pass steel cable through cord lock; fasten steel cable with screws.

① Tighten the 3 screws as much as possible.

② The bolt must make at least 10 turns towards the selector bar.

③ Tighten hexagon nut.

(6) Assemble steel cable as the diagram shows; check whether pulleys move smoothly.

(7) Assemble rear shroud; fasten it to tower frame with designated screws.

(8) Assemble water bottle holder; fasten it to tower frame with designated screws.

(9) Now the weight cage is assembled.

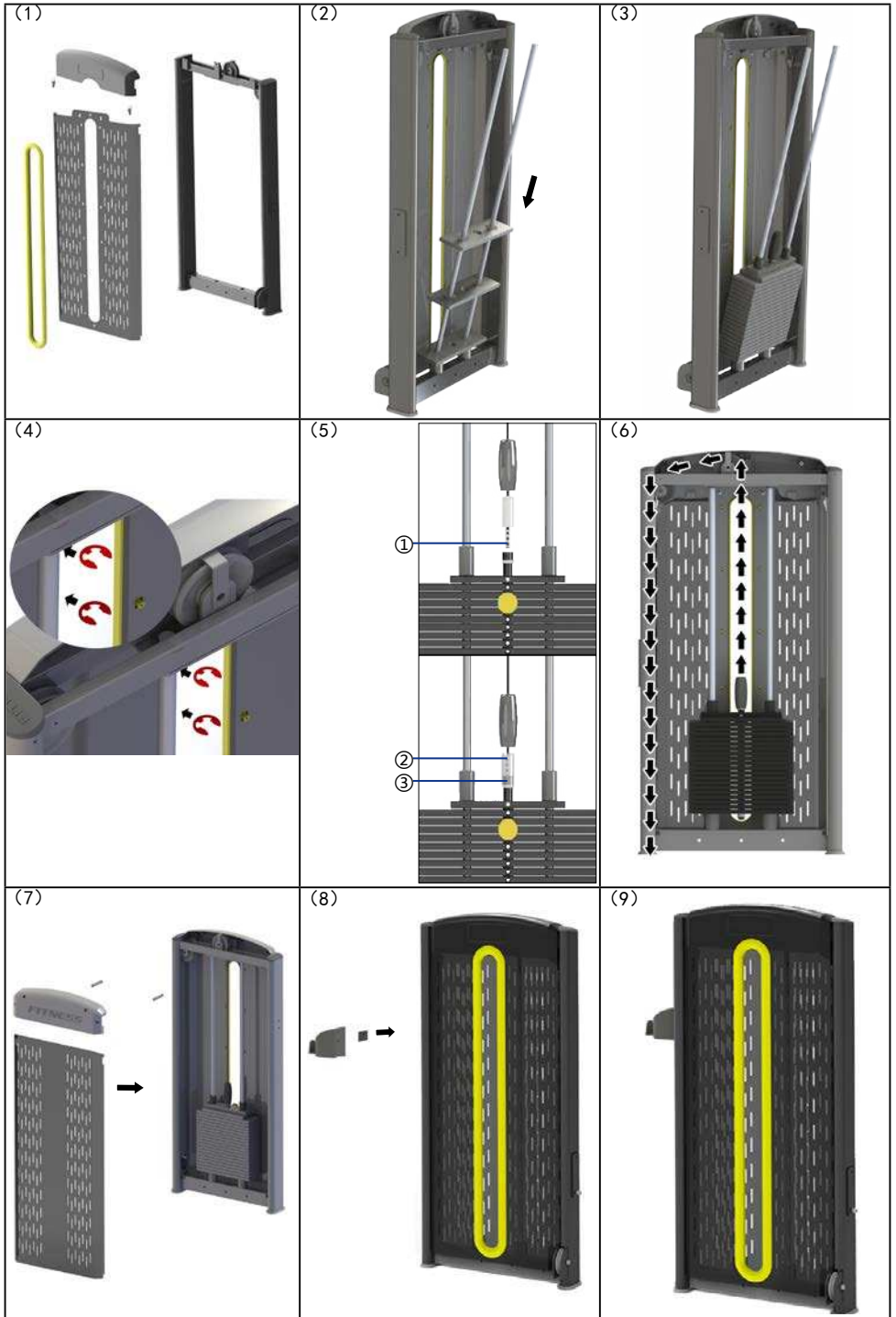

II.Assemble User Frame

1. Put the assembled Weight Cage in the area where the machine will be used. Check whether all the other parts are there according to the diagrams below; remove packing materials and place the parts tidily. Assemble Main Frame; as the diagram shows, attach Upper and Lower Connecting & Supporting Assemblies (AE1; AE2) to Weight Cage; fasten Main Frame Weldment Assembly (AC1) to Connecting&Supporting Assemblies. (Diagram 1)

2. Attach Transmission Assembly (AD1), Press Arm Assembly (AD2) to Main Frame Weldment Assembly. Tighten all the set bolts. Fix and adjust steel cable, ensuring that it moves smoothly without any twist or slack. (Diagram 2)

3. Assemble steel cable as the diagram shows; make sure that it moves along the trajectory as the arrow shows. (Diagram 3)

4. Assemble Seat Frame Weldment Assembly (AD3), Back Cushion Frame Weldment Assembly (AD4) and Adjustment Weldment Assembly (AD5). (Diagram 4)

5. Assemble Seat Cushion (D11-J01) and Back Cushion (K23-J01). (Diagram 5)

6. Recheck all links and tighten all screws in case of slack.

7. Finally, a trial must be taken by professional to assure that it's correctly assembled.

(1)

(2)

REF#	DESCRIPTION	SPEC.	QTY.
AB1	Shroud Assembly		1
AC1	Main Frame Weldment Assembly		1
AE1	Connecting&Supporting Asmly (upper)		1
AE2	Connecting&Supporting Asmly (lower)		1
E05	Cover Plate, Arcuate	180°55.8°T3	2
GB11	Hexagonal Bolt	M12*25	4
GB91	Flat Washer	M12	4
GB586	Hexagon Socket Head Cap Screw	M10*145	4
GB90	Flat Washer	M10	6
GB83	Hexagonal Check Nut	M10	4

REF#	DESCRIPTION	SPEC.	QTY.
AD1	Transmission Assembly		1
AD2	Press Arm Assembly		1
D24	Axle	Φ25*175	1
D25	Spacing Ring	Φ35*4.5	4
D35	Stationary Cover, Axle	Φ49*5.0	4
D14	Pull Pin, Long	Φ16*194	1
D28	Cap, Pull Pin	Φ22*16	1
D25	Limit Block, Knob	Φ18*12.5	1
M040	Front End, Pull Pin Handle	Φ24*22.5	1
M039	Pull Pin Handle	Φ50*34.5	1
SC015	Deep Groove Ball Bearing	GB6005	4
GB49	Hexagon Socket Button Head Screw	M8*20	4
N01	Rubber Sleeve, Cam Screw	Φ18*10	2
GB21	Hexagon Socket Head Cap Screw	M8*25	2
GB82	Hexagonal Check Nut	M8	2

(3)

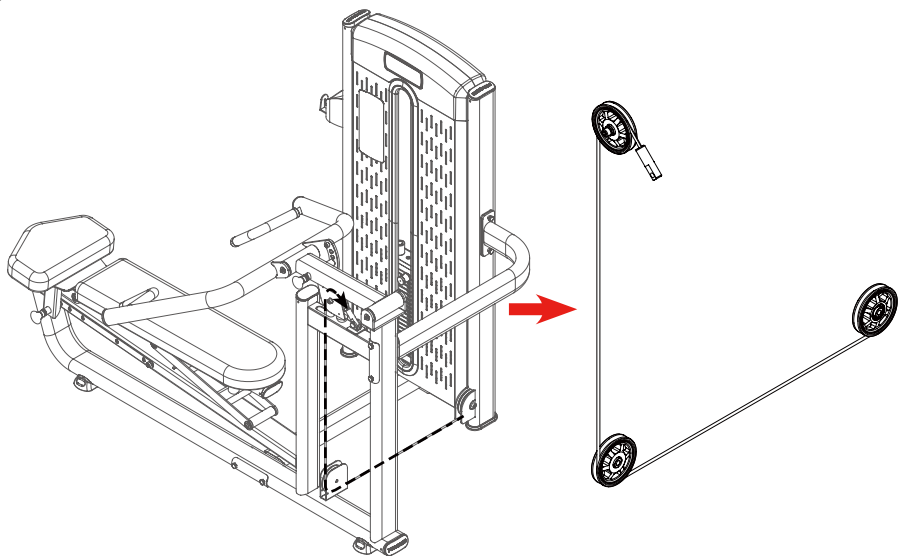

(4)

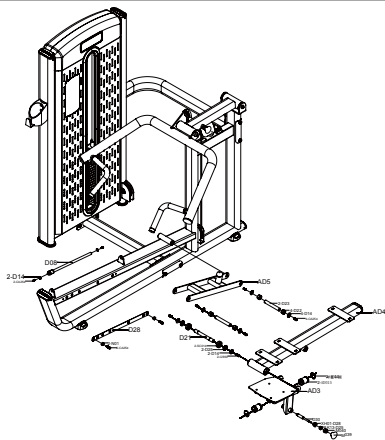

REF#	DESCRIPTION	SPEC.	QTY.
AD3	Seat Frame Weldment Assembly		1
AD4	Back Cushion Frame Weldment Assembly		1
AD5	Adjustment Weldment Assembly		1
D08	Shaft Rod	Φ25*650	1
D28	Decorative Plate	30*530*T2.0	1
D14	Decorative End Cap	Φ30*6.0	8
D21	Axle	Φ20*172	1
D23	Axle Center	Φ20*135	2
D22	Nylon Sleeve	Φ28*15	4
D30	Pull Pin, Short	Φ16*138	1
N01	Rubber Sleeve, Cam Screw	Φ18*10	2
AD015	Linear Bearing	LM25UU	2
D25	Spacing Sleeve	Φ35*4.5	2
K13-D25	Limit Block, Knob	Φ18*12.5	1
XH01-D28	Cap, Pull Pin	Φ22*16	1
M040	Front End, Pull Pin Handle	Φ24*22.5	1
M039	Pull Pin Handle	Φ50*34.5	1
GB50	Hexagon Socket Button Head Screw	M8*25	10

(5)

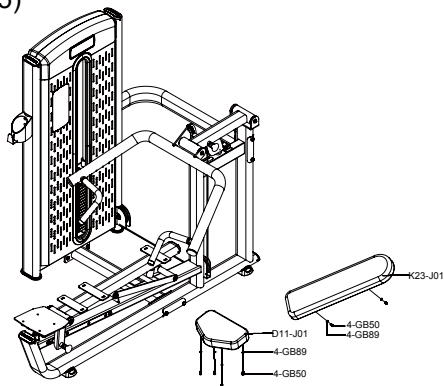

REF	DESCRIPTION	SPEC.	QTY.
D11-J01	Seat Cushion		1
K23-J01	Back Cushion		1
GB50	Hexagon Socket Button Head Screw	M8*25L	6
GB89	Flat Washer	M8	6

TARGET MUSCLE DIAGRAM (SEATED SHOULDER PRESS)

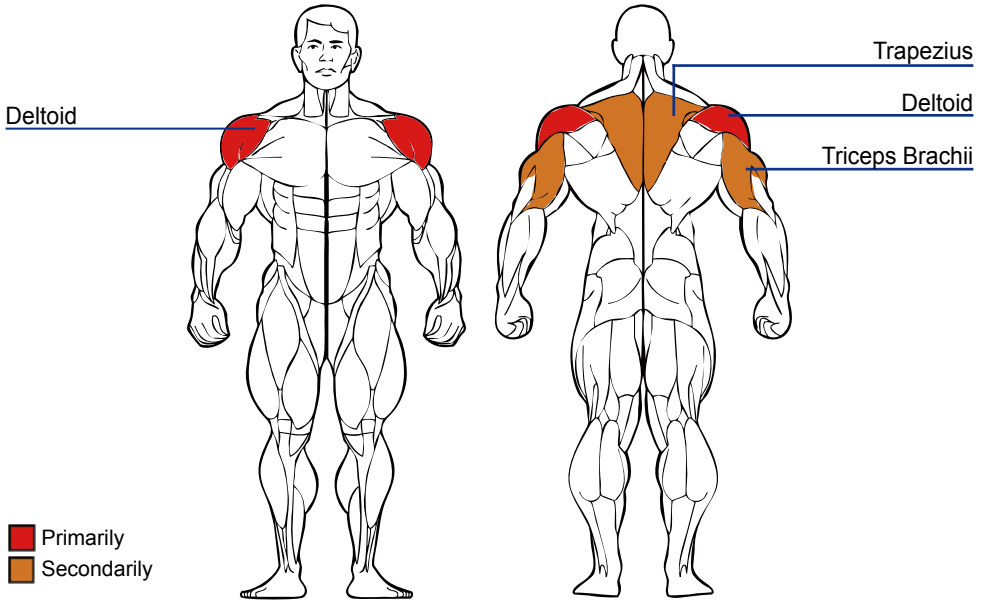

TARGET MUSCLE DIAGRAM (HORIZONTAL SHOULDER PRESS)

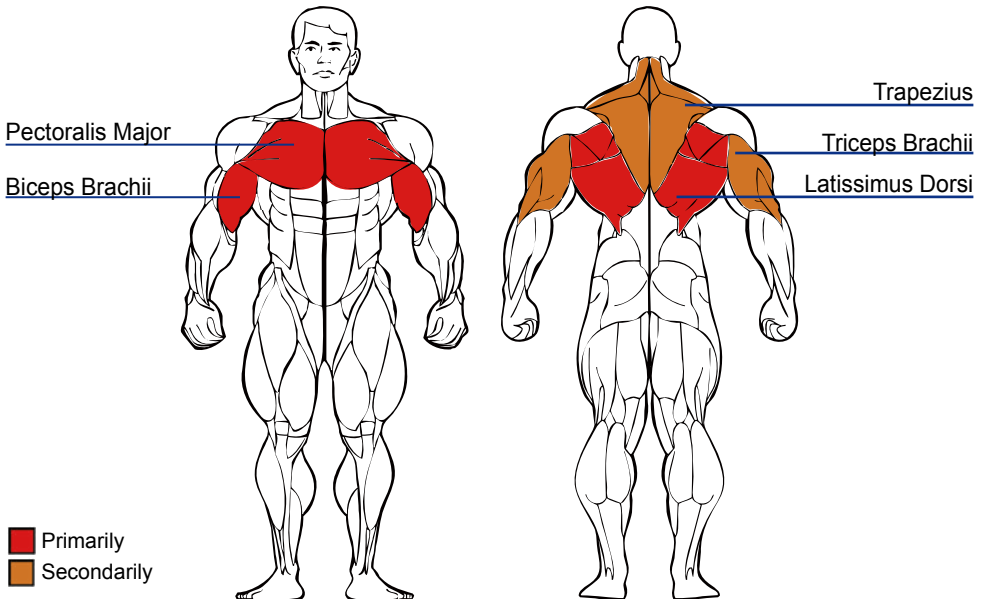

USAGE GUIDANCE (SEATED SHOULDER PRESS)

START

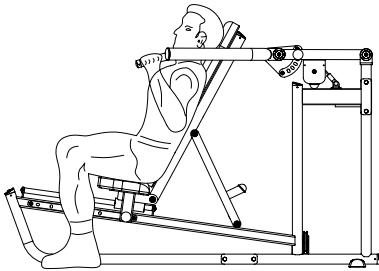

FINISH

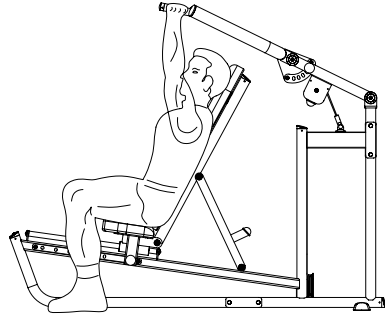

Instructions

Select an appropriate weight resistance according to personal condition. Adjust seat and back cushion angles by pulling the yellow adjustment lever beneath seat cushion. Sit with your back firmly against back cushion. Adjust press arm angle by pulling the yellow lever at it (as the diagram above shows). Grasp handgrips suitable for you. Please consult a coach if you are unsure.

Exercise Movement

Grasp handgrips with both hands; push them forward till both arms are fully straightened. Then return to the starting position slowly, ensuring that the moving weight plates do not touch the static ones. Repeat the movements. Please consult a coach if you experience any pain when you stop suddenly.

USAGE GUIDANCE (HORIZONTAL SHOULDER PRESS)

START

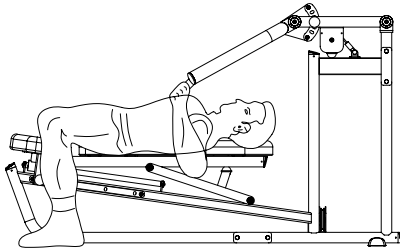

FINISH

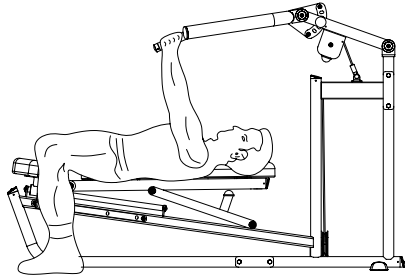

Instructions

Select an appropriate weight resistance according to personal condition. Adjust seat and back cushion angles by pulling the yellow adjustment lever beneath seat cushion. Lie down with your back firmly against back cushion. Adjust press arm angle by pulling the yellow lever at it (as the diagram above shows). Grasp handgrips suitable for you. Please consult a coach if you are unsure.

Exercise Movement

Grasp handgrips with both hands; push them forward till both arms are fully straightened. Then return to the starting position slowly, ensuring that the moving weight plates do not touch the static ones. Repeat the movements. Please consult a coach if you experience any pain when you stop suddenly.

EXERCISE NOTICES

1. 5~10 minutes of warm-up must be taken prior to having exercise on this machine. Record the time while having free exercise which aims to activate the joints in case of injury to them during training.

2. Inspection must be carried out prior to using the machine. For any potential problem, please contact the coach or maintenance staff immediately. Do not use it before it's assured that it can operate correctly.

3. Do not use the machine if there's a sign on it that tells it malfunctions.

4. Please take high-protein foods, vegetables and fruits. Have a meal 40 min prior to the exercise and another meal no sooner than 30 min after it. A small amount of water can be taken during exercise.

5. Inhale when you exert yourself; exhale when you relax. Adjust breath according to movements.

6. The next workout for same muscle must be taken after at least 48 hours of rest.

7. Weight resistance should be selected according to personal condition. Excessive weight must not be taken in case of injury to muscles. The training must be proceeded in an orderly way and step by step. It is normal to feel slight pain in the muscles during the first workout.

MAINTENANCE AND TROUBLESHOOTING

1. Inspect bolts at all mechanical parts frequently for tightness; rotating parts should rotate smoothly without producing any abnormal sound.

2. When the machine is static, steel cable should be tightened while weight plates should not be suspended.

3. The machine should be kept clean but not wiped with strong cleaning solvents.

4. Bolts at all the adjustment parts should be tightened after adjustment in case of slack.

5. If any loading part, e.g., steel cable, pulley, pulley case, weight plate, is abraded or damaged, it must be replaced immediately; the machine can only be put into use after repair.

Basic Troubleshooting

Fault	Reason	Solution	Remarks
Unstable Frame	A. Uneven floor or foreign object B. Unadjusted leveling feet after assembling frame	Remove foreign object, Loose main frame bolts, adjust leveling feet, tighten the bolts	Owner
Idle running during operation	Steel cable is too loose	Tighten steel cable	Owner
Impact on steel cable during resetting	Steel cable is too tight; weight plates are suspended	Loosen steel cable	Owner
Pulleys cannot rotate	Steel cable is stuck between pulley and pulley case	Dismantle pulley and reassemble it	Owner
Abnormal sound at rotating part of pulley	A. Abraded or damaged pulley B. Abraded or damaged pulley cover C. Abraded or damaged bearing D. Abraded or damaged steel cable	Replace pulley Replace pulley cover Replace bearing for pulley Replace steel cable	After-sales Service
Abnormal sound at other rotating part	A. Abraded or damaged bearing B. Loose bolt C. Incompletely engaged pin	Replace bearing Tighten bolt Get pin fully engaged	After-sales Service Owner Owner

If the machine malfunction is not referred in the text above, please contact the customer service centre or call us, you'll receive satisfactory service.

PREVENTIVE MAINTENANCE

1. Daily Inspection

Clean and inspect machine frame every day; clean upholsteries; inspect steel cable and the terminals for abrasion.

Clean upholsteries and machine frame with neutral soapy water, remove dirt, oil stain and perspiration on the surfaces and air dry them completely. Inspect the frame for rupture, rustiness and other damage. Make sure that soldering points and fastening parts are correctly fixed.

Fastening parts may get loose during normal use; therefore, please inspect all the nuts, bolts, screws and other fastening parts, make sure they are well tightened and correctly assembled. The machine can only be put into use when no problem is found.

Regular inspections of steel cable, pulleys, fastening parts and other accessories must be carried out. Frequently used cable may be damaged and broken due to abrasion; sudden damage or rupture may cause severe injuries to users. Hence, daily inspection of cable and connections at the terminals must be implemented. Check whether there's kink or abrasion, whether sheath and terminals are damaged. Special attention must be paid to the terminals and the parts of cable which are in contact with pulleys. **Damaged cable must be replaced immediately in case of injury to users.**

Characteristics of Obvious Steel Cable Damages (Picture 1)

(1) A tear or crack in the cable sheath that exposes the cable; or the part of sheath which pulley contacts is cracked.

(2) Z-type twist or a curled sheath.

(3) Kinks which indicate that internal of cable may be damaged.

(4) Necking-A stretched cable sheath.

(5) Cable sheath gets inflated.

In addition, the following inspections must be carried out.

(1) Make sure that steel cable is correctly adjusted and securely fastened to the top of weight plates. Make sure that cable is securely connected to pulleys and all assemblies are well fixed, all the seven cable strands pass through the selector bar and screws are well tightened.

(2) Wipe and clean all warning/instruction stickers. (Picture 2)

(3) After some time of use, steel cable may get loose due to stretches. It can be solved by adjusting the hexagon nut on the head plate in time; tighten hexagon nut in case of slack. If it fails, cut a small section of the cable and refasten it. (For adjustment and assembly of steel cable, please check Assemble Weight Cage, ASSEMBLY INSTRUCTIONS.)

Picture 1:

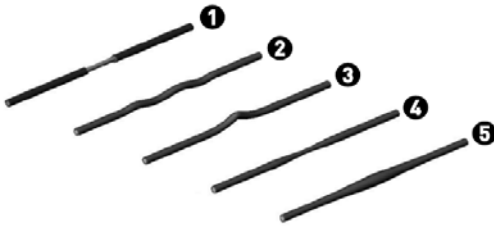

Picture 2:

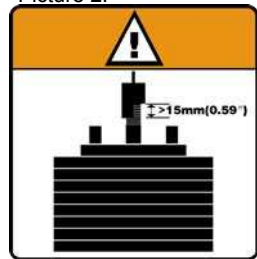

2.Weekly Inspection

Clean upholsteries; clean and lubricate cable rod end; clean and lubricate guide rods; inspect cable, connecting parts, and cable tension; inspect cable accessories; inspect pulleys; inspect each weight plate and selector pin; inspect and lubricate bearings and bushings; inspect seat adjustment system; test the pop pin.

(1) Clean upholsteries with special detergent. **Note: It must be neutral detergent. Never use detergent which contains solvent, ethanol, ammonia or petroleum.**

(2) Inspect heim joint and assure that the shoulder screw is well tightened. If there's noise inside the heim joint, lubricate it with silicone oil as shown in Picture 1 on Page 18. Wipe them with cloth to remove excessive oil.

(3)Inspect the exposed parts of guide rods; keep them clean; remove dirt and oil stain on the rods with soft cloth. (Note: You can only inspect, clean and lubricate guide rods after dismantling shrouds.)

(4)Spray silicone oil onto the exposed parts of guide rods or cloth, and then wipe guide rods with cloth. **Never lubricate the rods when the machine is in use; the parts which are hidden in weight plates can only be lubricated after the weight plates are removed, otherwise, it will cause severe injuries.**

Reminder: Do not use petroleum-based lubricant; it will lead to rapid accumulations of dirt and hair on weight plates and may get the weight plates stuck to each other.

(5)Inspect and test steel cable and the links thoroughly every week; inspect cable tension.

(6)Inspect cable connection at weight plates. Make sure that the bolt makes at least 10 turns (15mm) towards the selector bar. Inspect the two thin nuts at both ends of the nut and ensure that they are securely tightened.

(7)Inspect steel cable; pay special attention to parts which are in contact with pulleys and cams. Inspect links at cams; inspect bolts which pass through parts on the top of cams and assure that set screws are tightened.

(8)Inspect steel cable; make sure all connections are firm and secure, tension is appropriate and steel cable is correctly fixed on the top of weight plate.

(9)Inspect pulleys: check if there's abrasion, flaw, breach or deletion. Abrasion of pulley surface can lead to severe damage to steel cable. Therefore, abraded or damaged pulley must be replaced immediately. Make sure pulleys can revolve flexibly during usage and do not sway to left and right with big amplitude. Big amplitude indicates that set bolt or bearing is damaged; in this case, dismantle pulley and inspect it. If any

damaged bearing, it must be replaced immediately.

(10)Inspect weight plates and selector pin: check if there's burr or damage; wipe each weight plate and guide rod to remove dirt and dust. Make sure that selector pin can be fully inserted into each weight plate and stably retained there (Picture 2).

(11)Inspect bearings and lubricate shaft bushing: it's recommended that a small amount of silicone oil should be used for lubricating shaft bushing which is used for supporting shaft. Spray the oil onto shaft and twist the shaft several laps inside shaft bushing; meanwhile, check whether the bushing is excessively abraded or damaged.

Picture 1:



Lubricate it regularly

Picture 2:

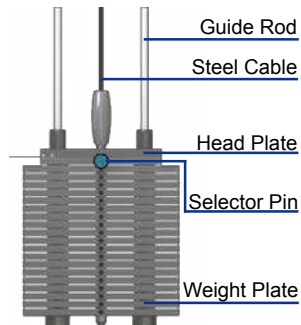

3.Monthly Inspection

(1)Inspect main frame and press arms: lubricate pop pin; inspect and lubricate seat post; inspect all fastening parts.

(2)Inspect main frame and press arms: check if they are complete and work normally; check if there's cracking, peeling paint or rustiness. Repair or replace the parts according to actual condition.

(3)Check if main frame is cracked. Pay special attention to solder joints. If any crack, suspend the machine immediately and contact maintenance staff to repair it.

(4)Check if there's rust or peeling paint on frame; if yes, wipe it gently with wet grainy cloth, dry emery cloth, or steel wire (fine thread) ball and

then repair paint chips.

(5) If the selector pin cannot be easily inserted into weight plate, check whether the selector bar swings leftward and rightward when it's in vertical position. (Picture 1)

(6) Workout duration and the number of repetitions can be conveniently checked if rep counter is turned on during exercise. If there's no display on rep counter, batteries need to be replaced. Open the rep counter, you can see two AAA batteries, replace them with new ones with the same specifications. It's recommended that they get replaced monthly. (Picture 3)

Picture 1:

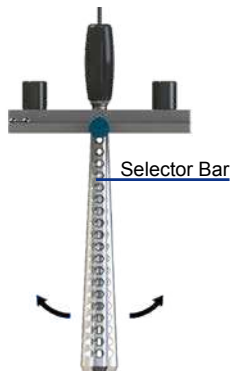

Picture 2:

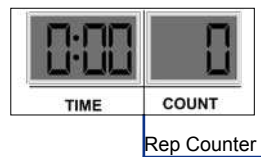

4. Annual Maintenance

(1) Dismantle shrouds and carry out necessary maintenance. It's recommended that one should dismantle weight plates, clean and inspect them thoroughly. Carefully take steel cable and guide rods off weight plates; clean and inspect each weight plate; inspect guide rod bushing. If any damaged part, replace it immediately. Clean guide rods and the selector bar; reassemble weight plates and shrouds. We recommend that abraded or damaged cable get replaced during regular maintenance; and all cables should be replaced with new ones annually.

(2) Inspect and lubricate the pop pin.

WARRANTY

1.Scope of Warranty: Non-artificial damage during normal usage of product maintained properly is in the scope of warranty. The warranty card only belongs to the original purchaser and is non-transferable.

2.The warranty period is one year from the date of purchase.

3.Damages below are beyond the scope of warranty:

(1)Damages which result from abuse, negligence, accident or unauthorized modification.

(2)Damages which result from incorrect adjustment of selector pin.

(3)Damages to machine parts which result from improper maintenance.

(4)Damages which result from operations against regulations.

For more information of us,

Please call +86-(10)-84933568, or email to body@mbhfit.com,

Or check our website: <http://www.mbhfit.com>.

After-sales Service Hotline: +86-400-832-9898; Postcode:100107

Factory Address: Yinhe Economy&Technology Industry Zone, Ningjin

County, Dezhou, Shandong Province, China

Sales Office Address: Room 106, 1/F, Building 16, Area 5, Yard 5, Beiyuan Rd., Chaoyang Dist., Beijing, China

